

Grade /

Fun Packet

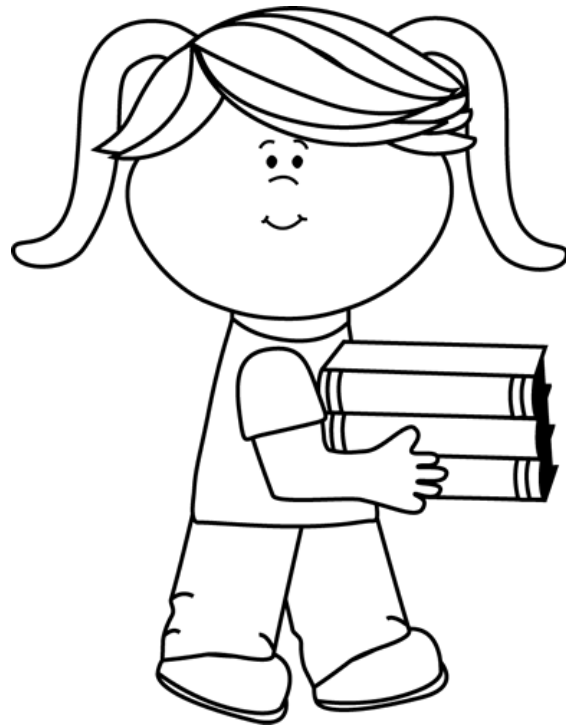

Name:

Help the turtle to
cut the lines.

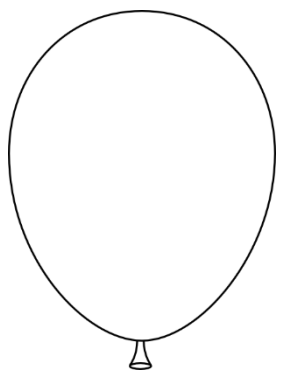
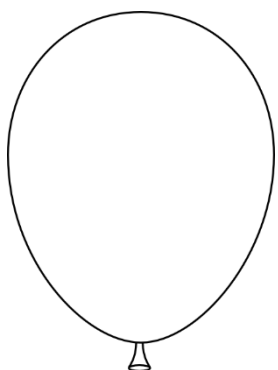
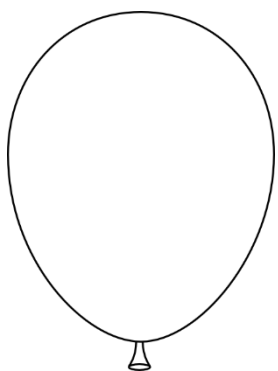
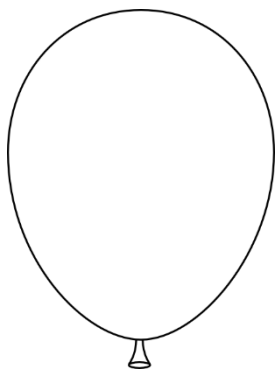
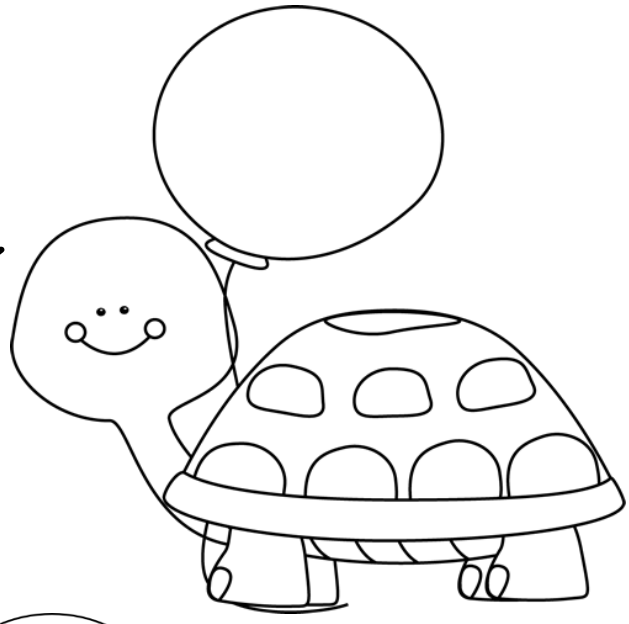

Let's cut!

Cut the square out.

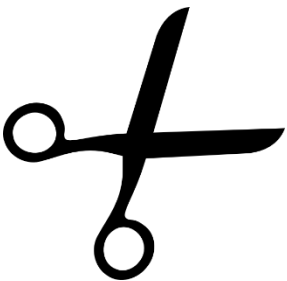
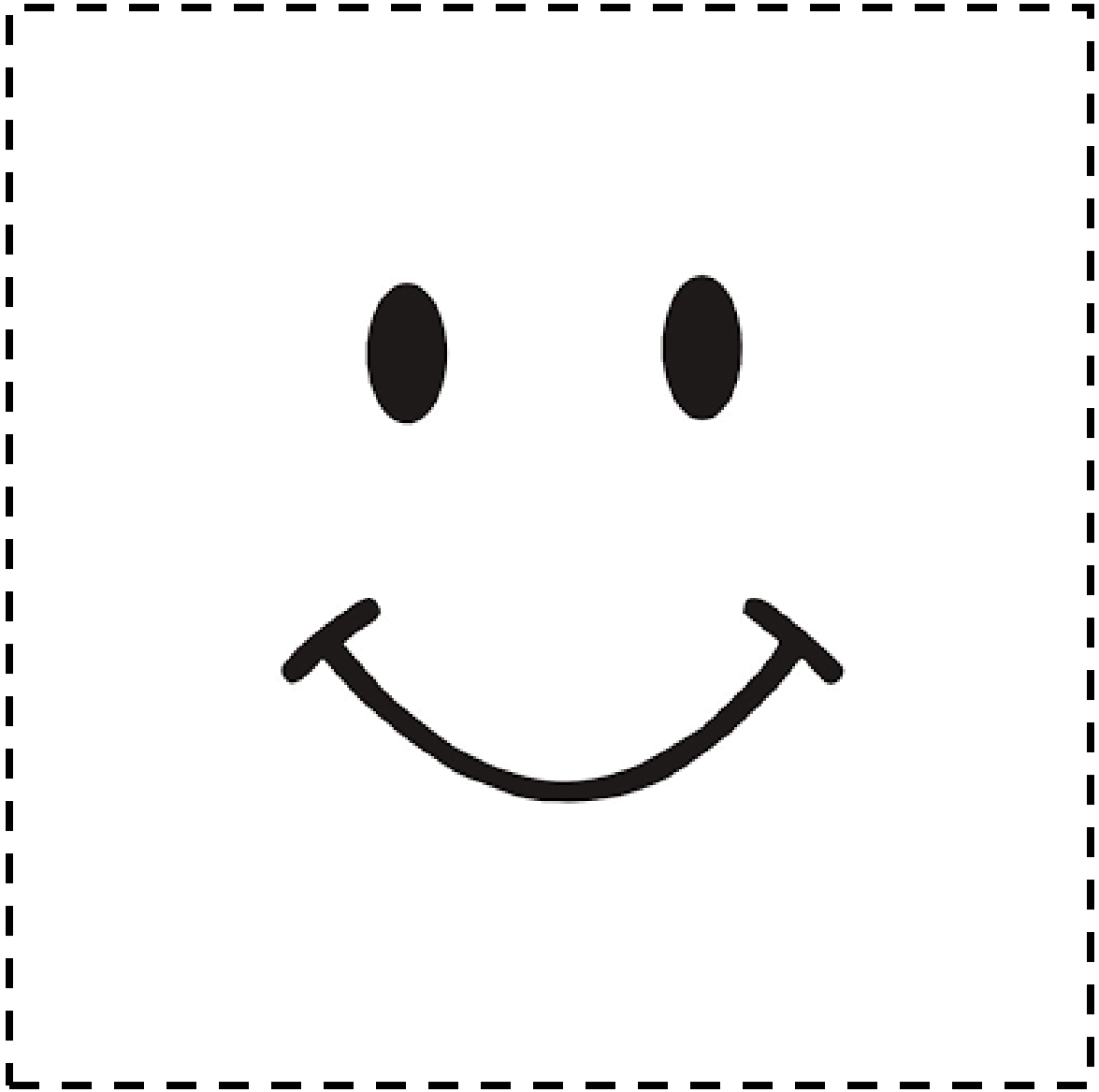

Let's cut!

Cut the circle out.

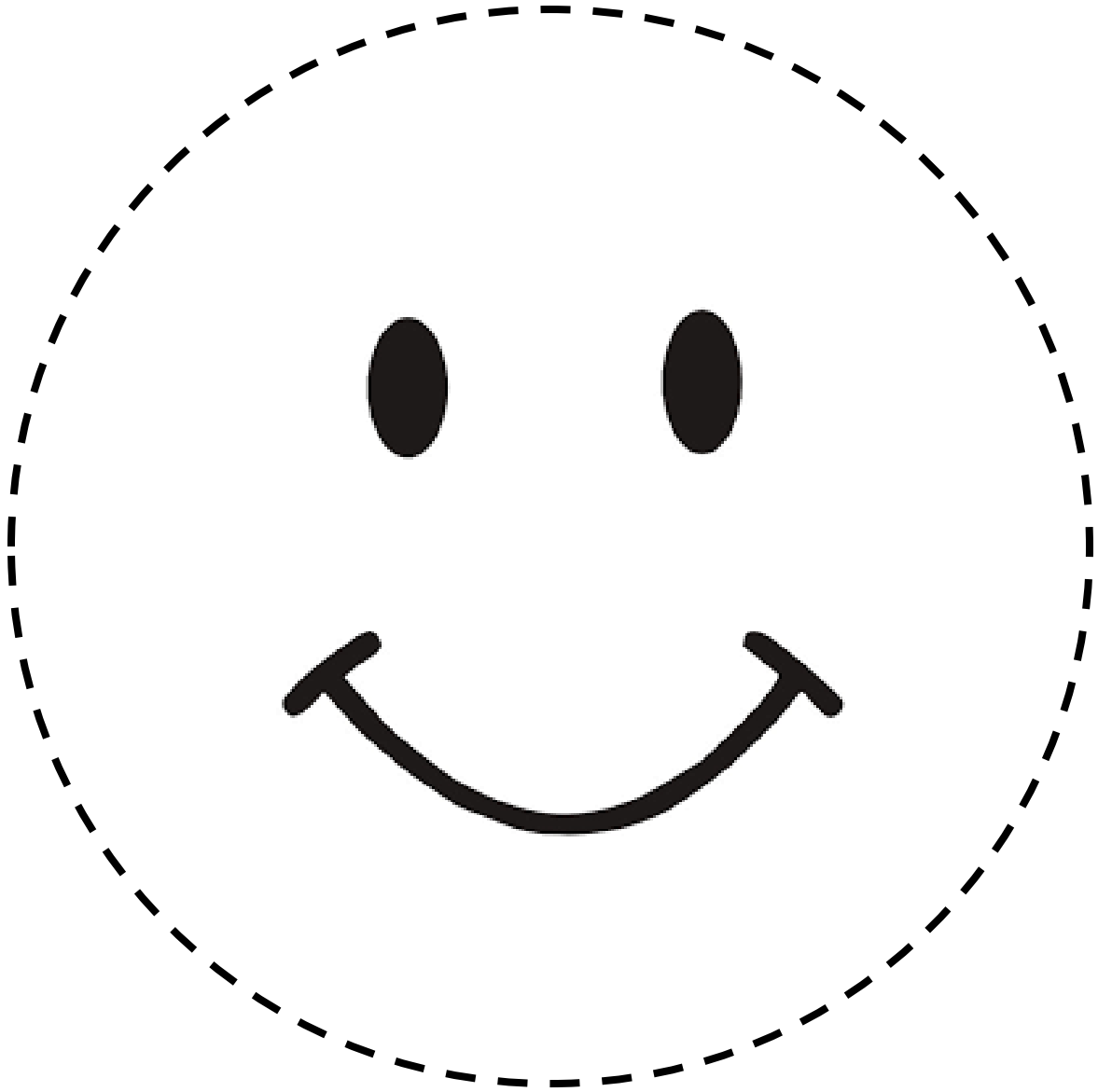

Circle fun

Practice the circle.

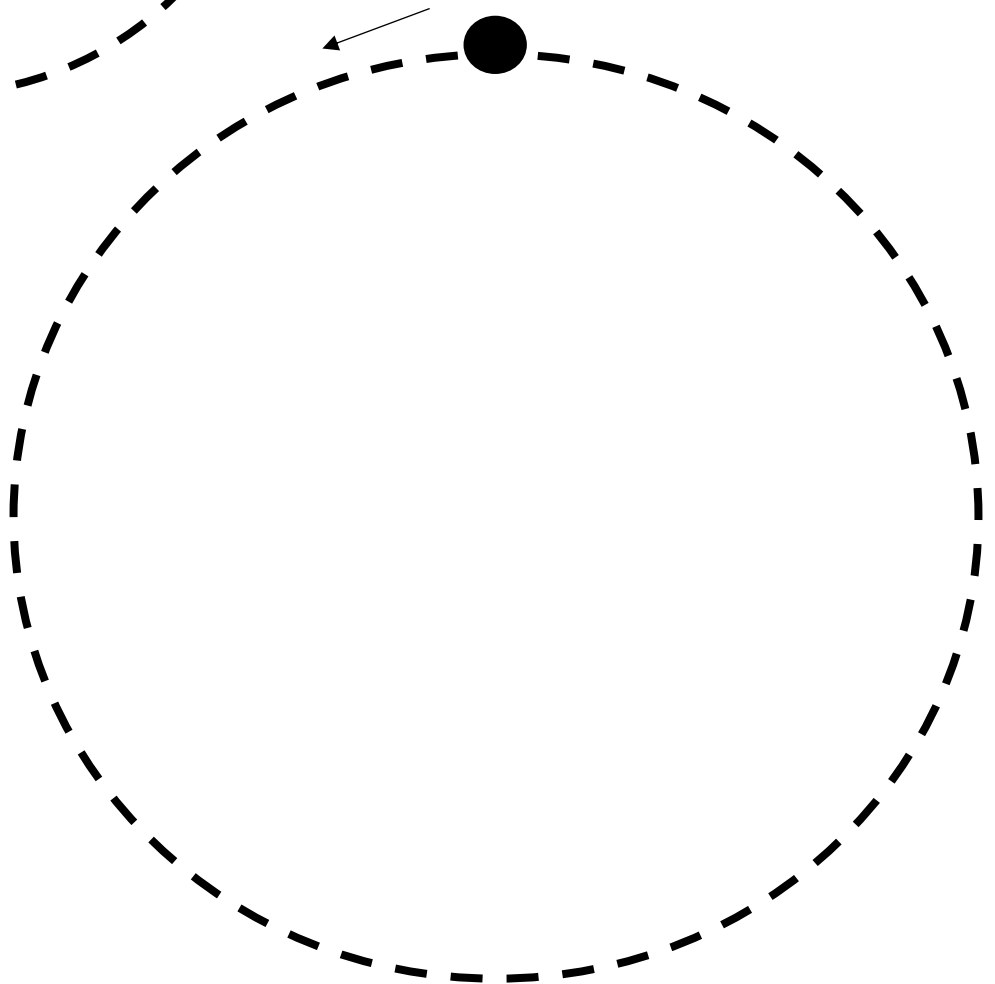
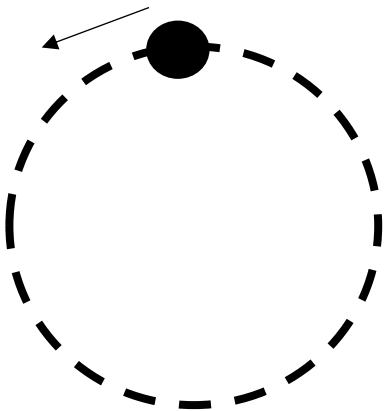
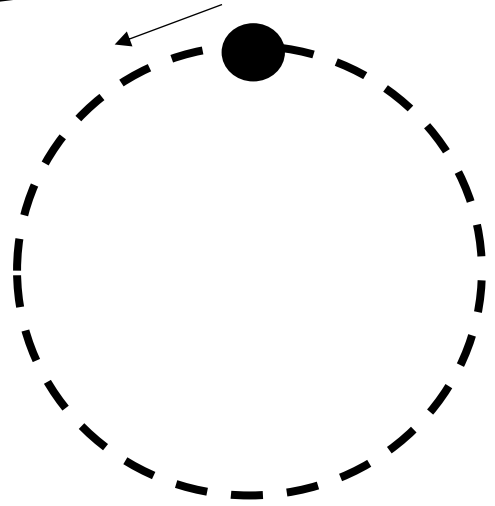
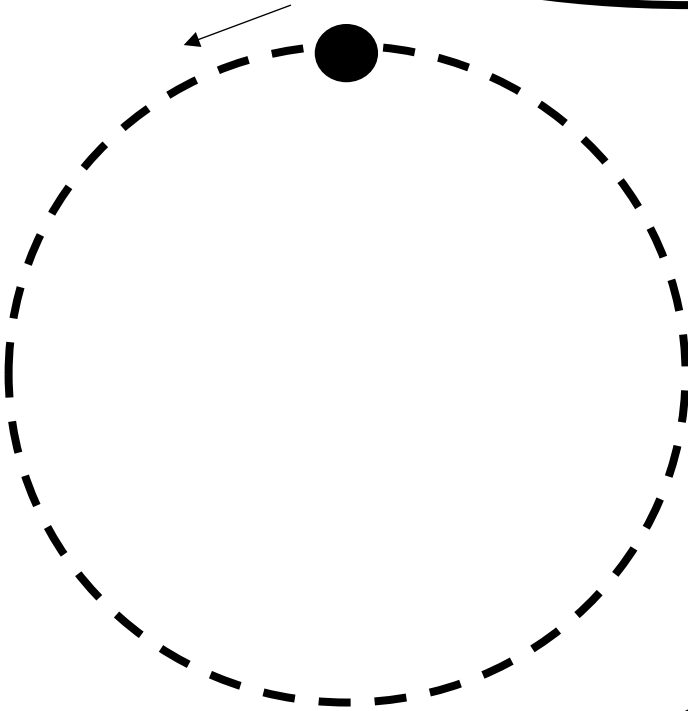
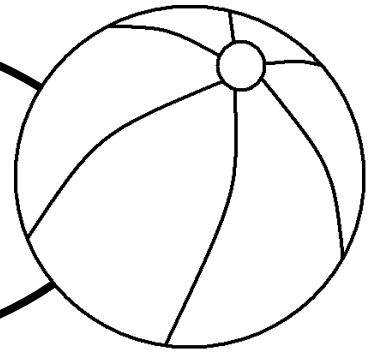

The bee is very loving.
Practice making
hearts for him.

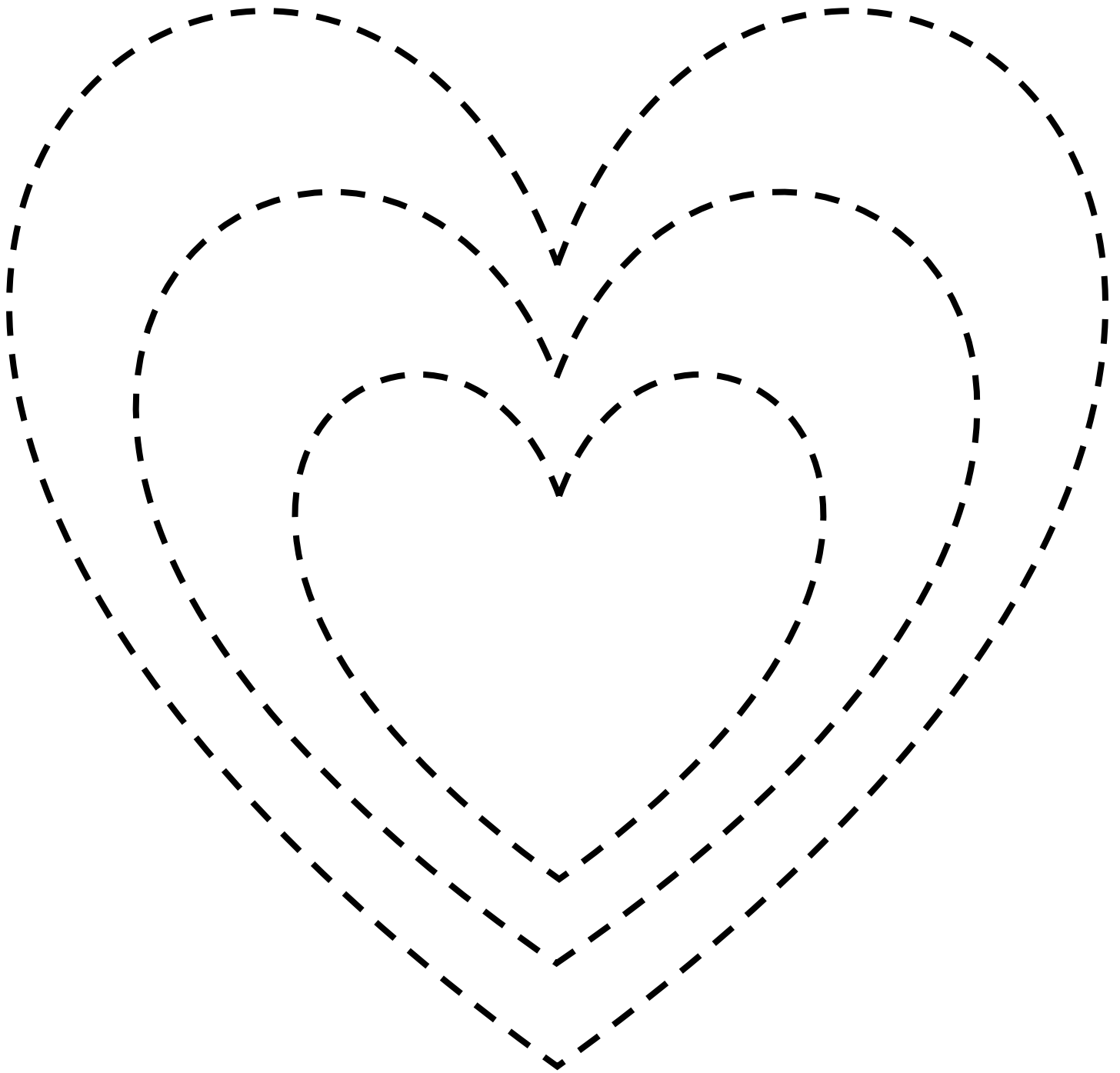
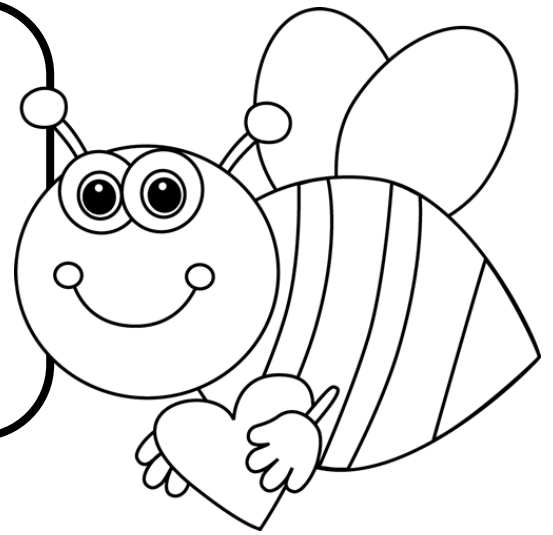

Complete the robot
patterns.

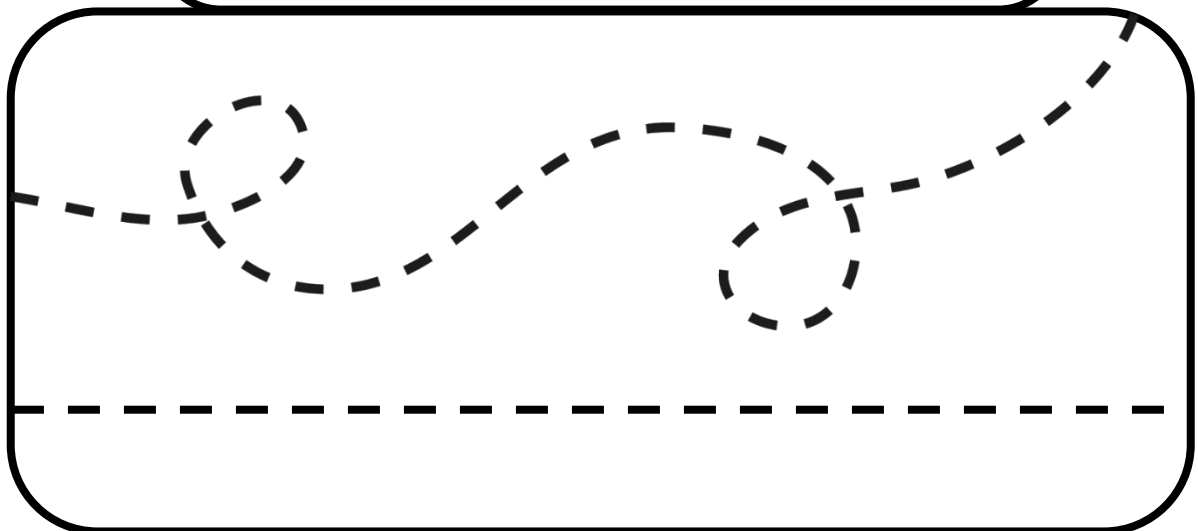
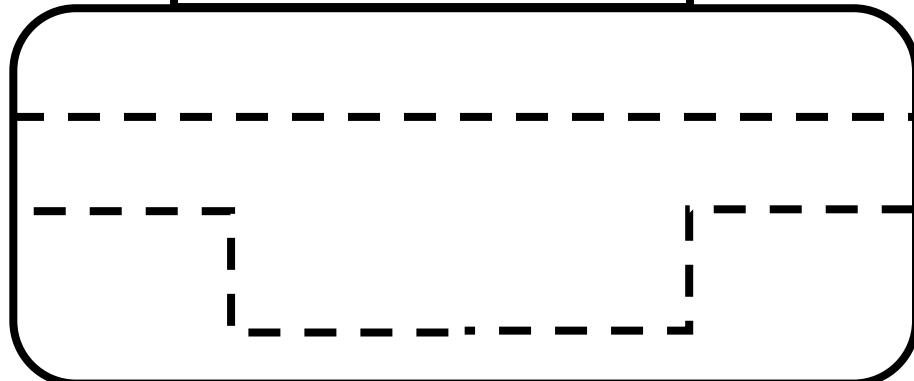
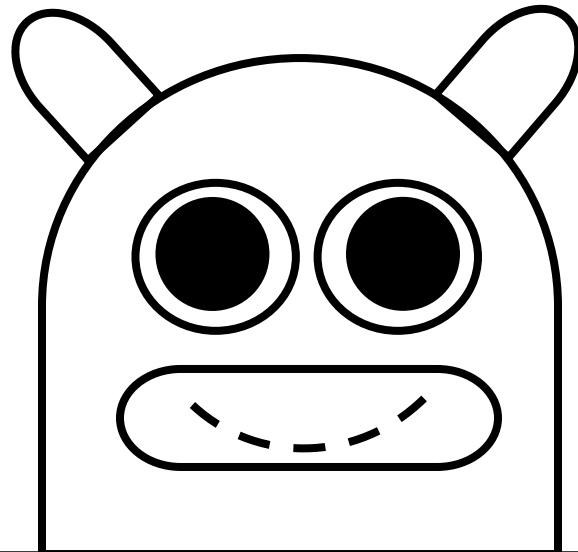

Let's practice the
square.

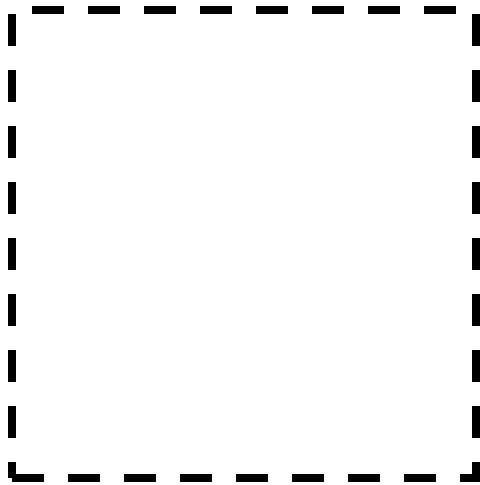
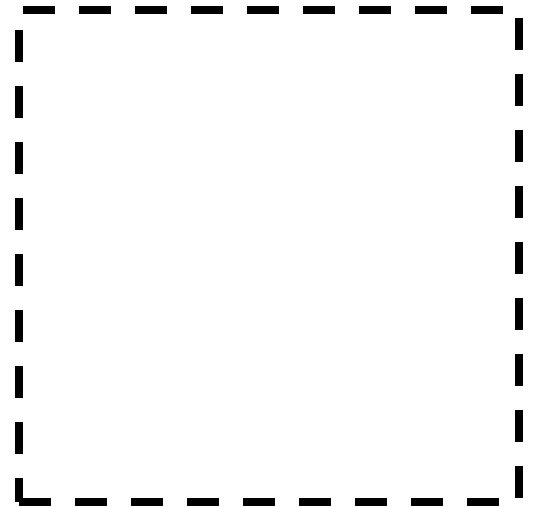
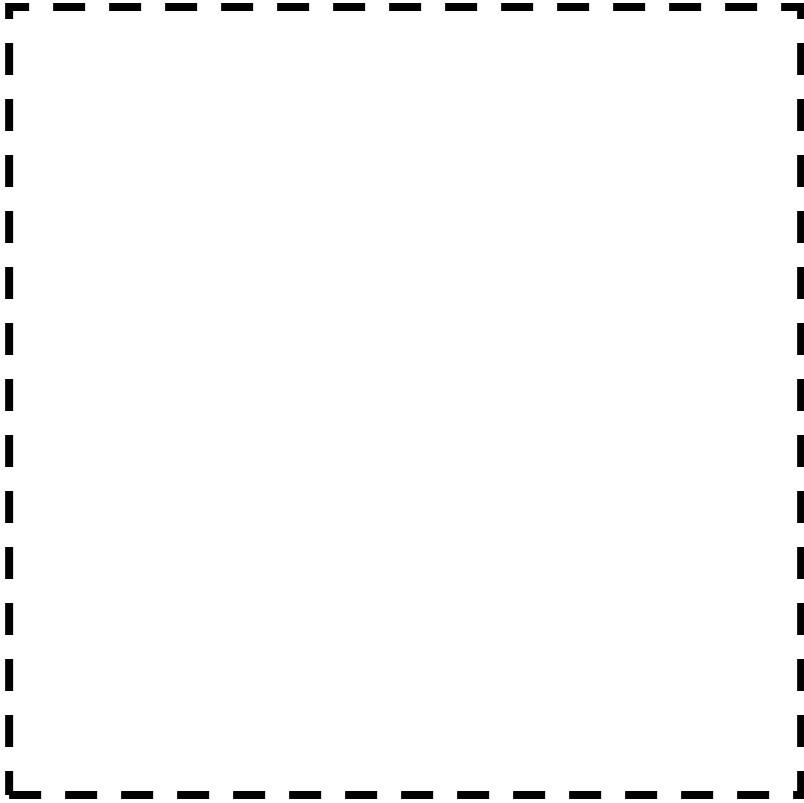
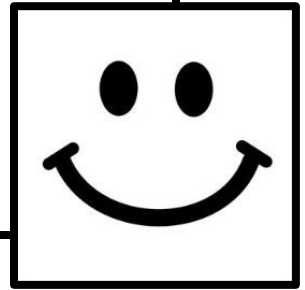

Complete the picture
on the dashed lines.

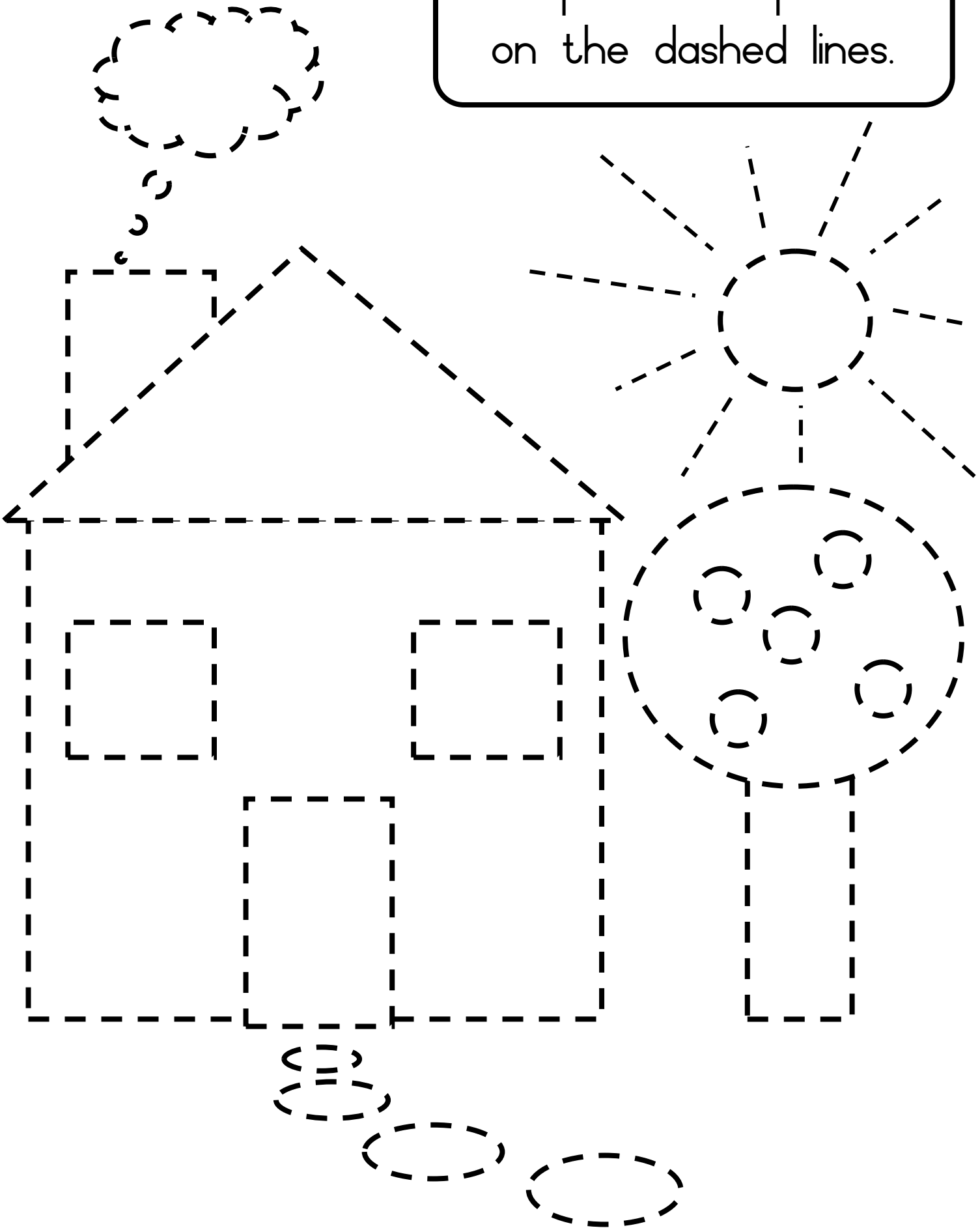

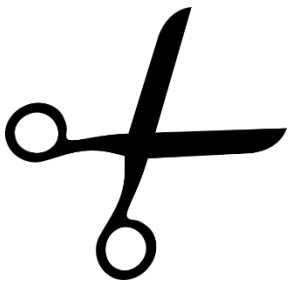

Colour the shapes.

Cut them out.

Paste them on the shapes on the next page.

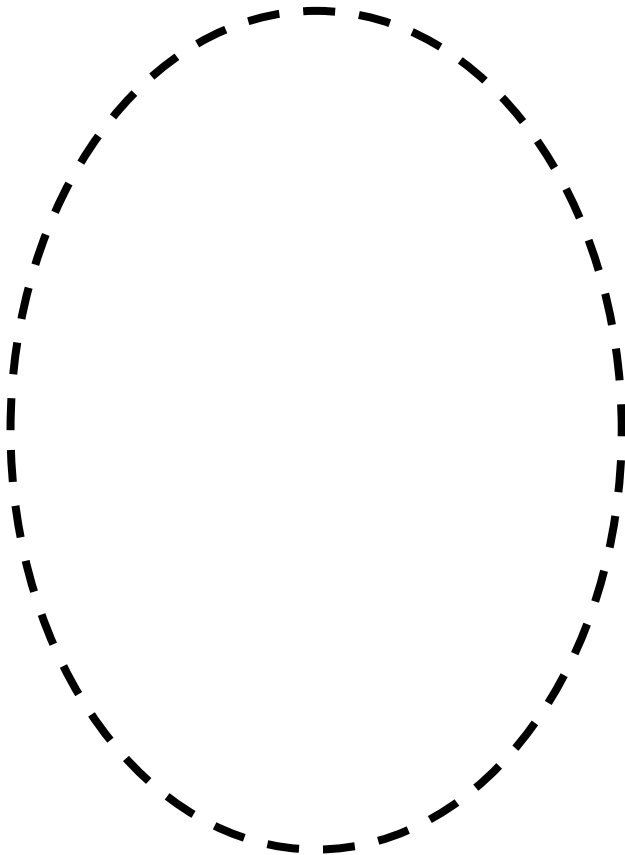
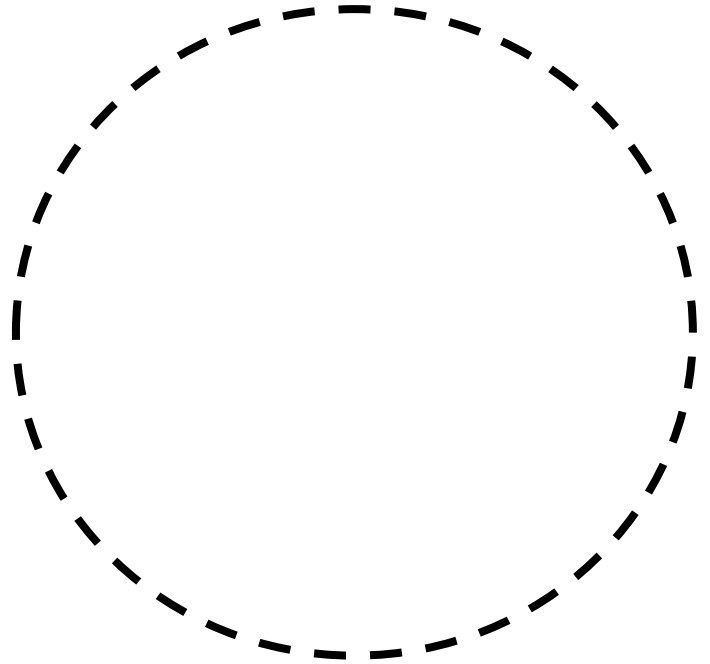

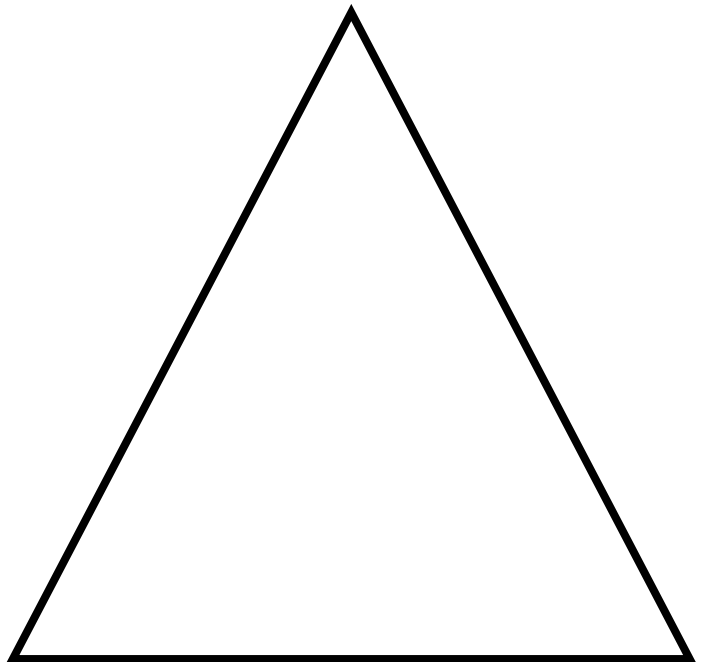
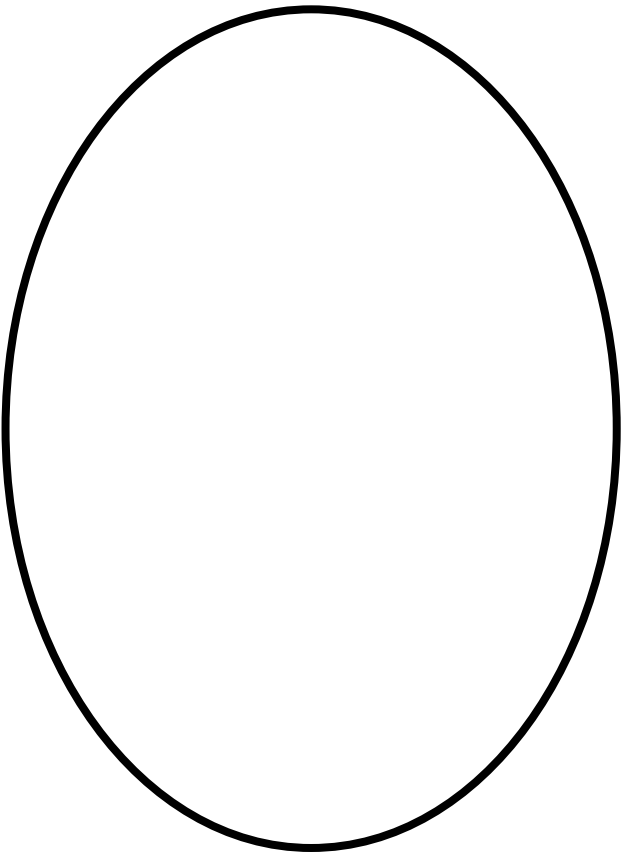
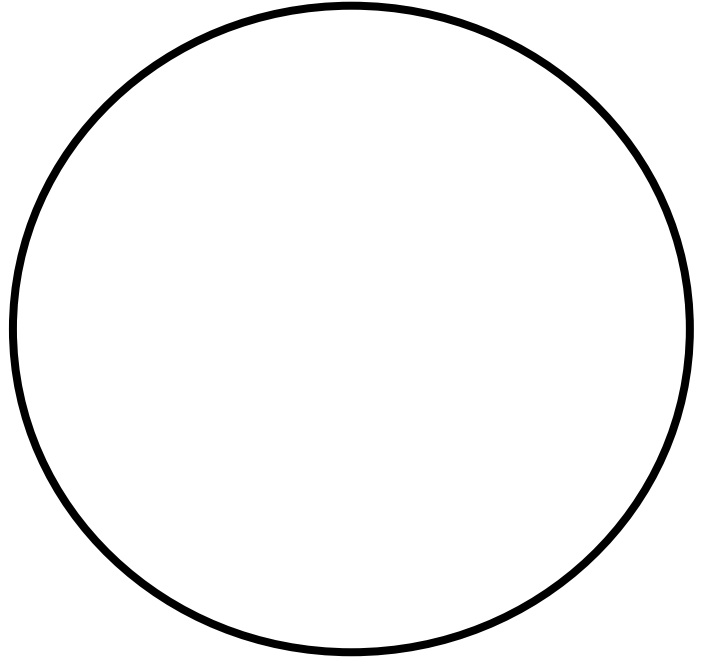

Use a magazine to cut out red pictures and paste them



Use a magazine to cut out blue
pictures and paste them

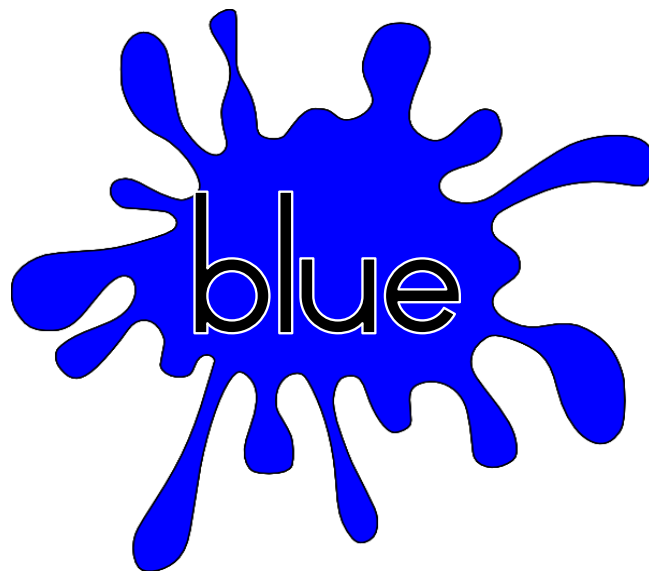

Use a magazine to cut out purple
pictures and paste them

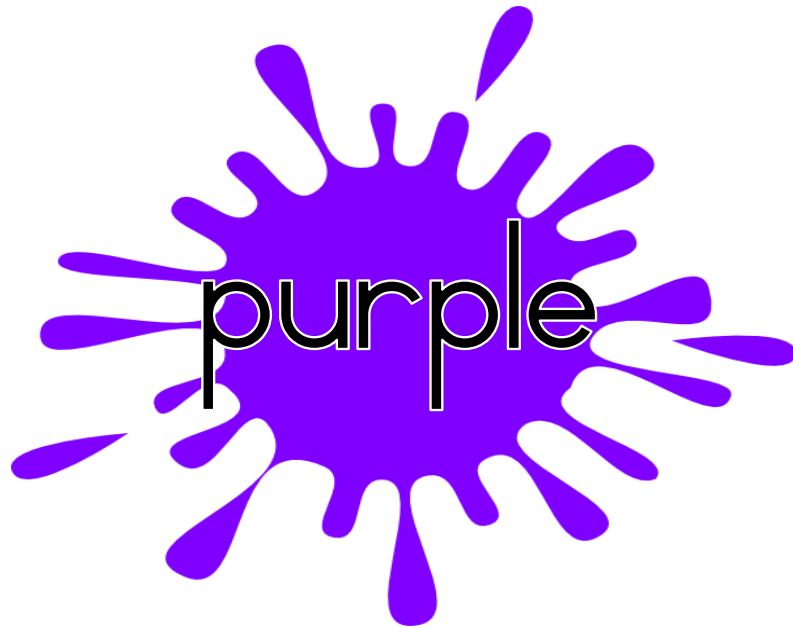

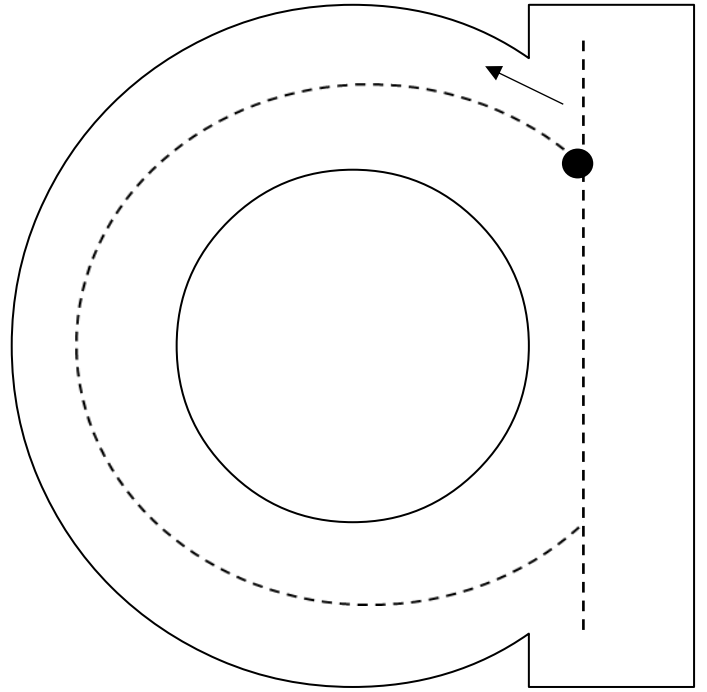
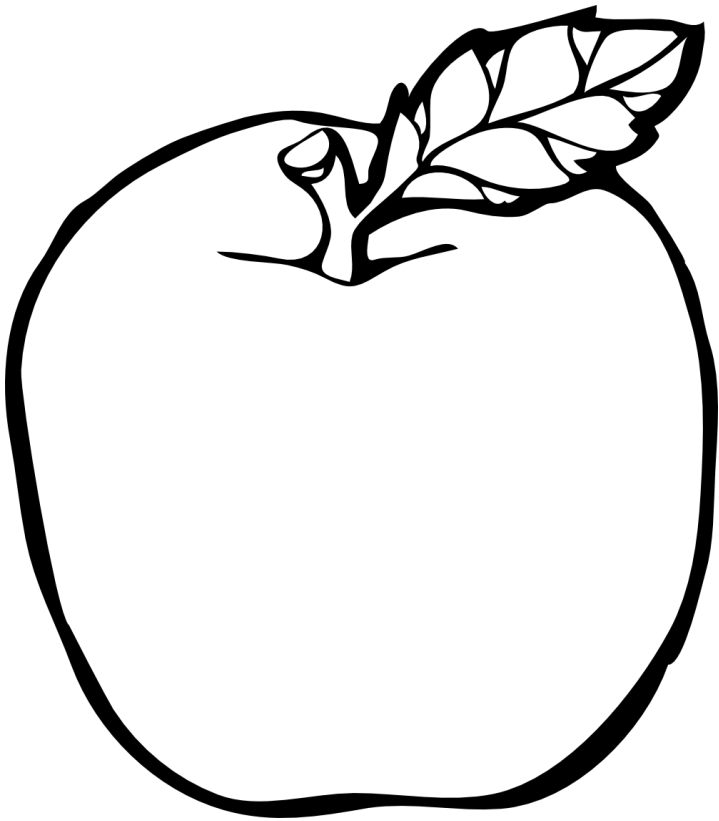

apple

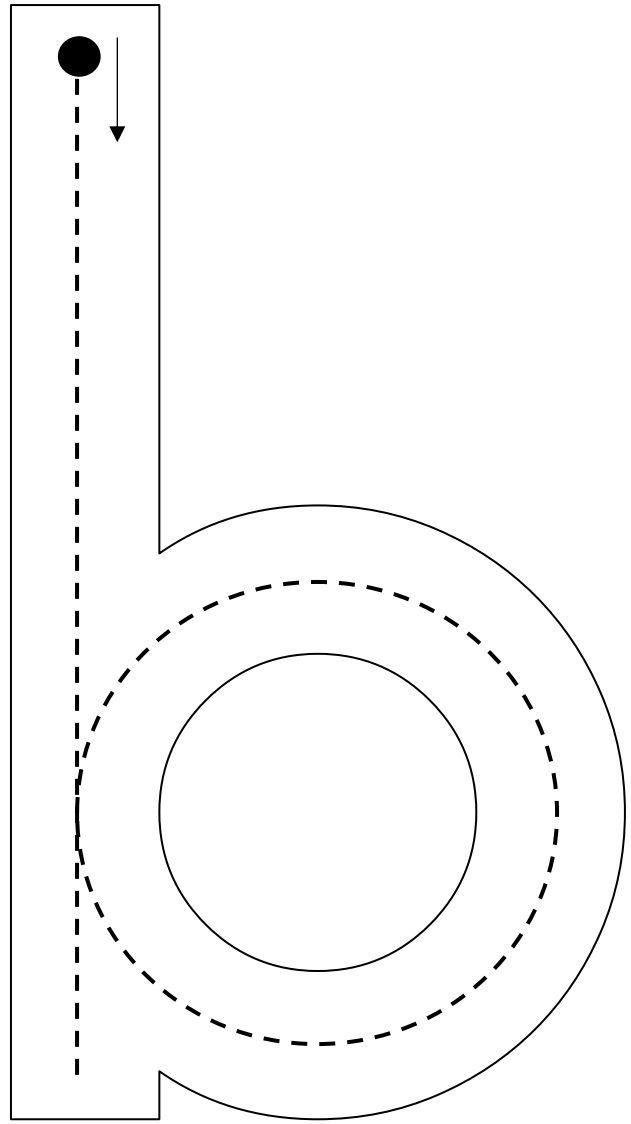

ball

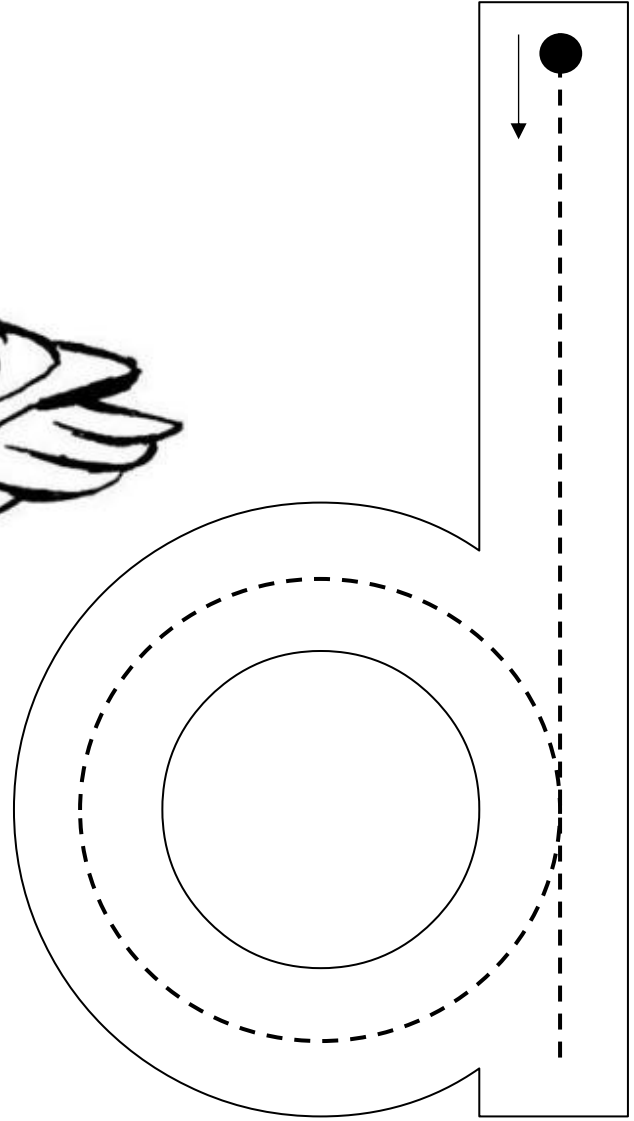
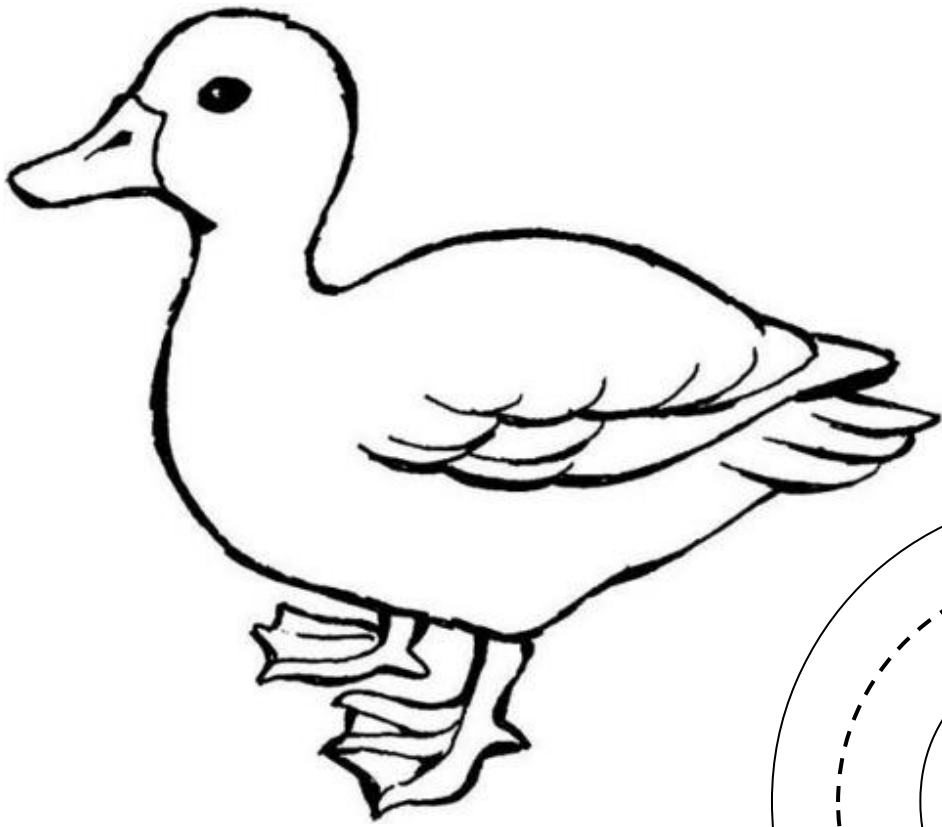

duck

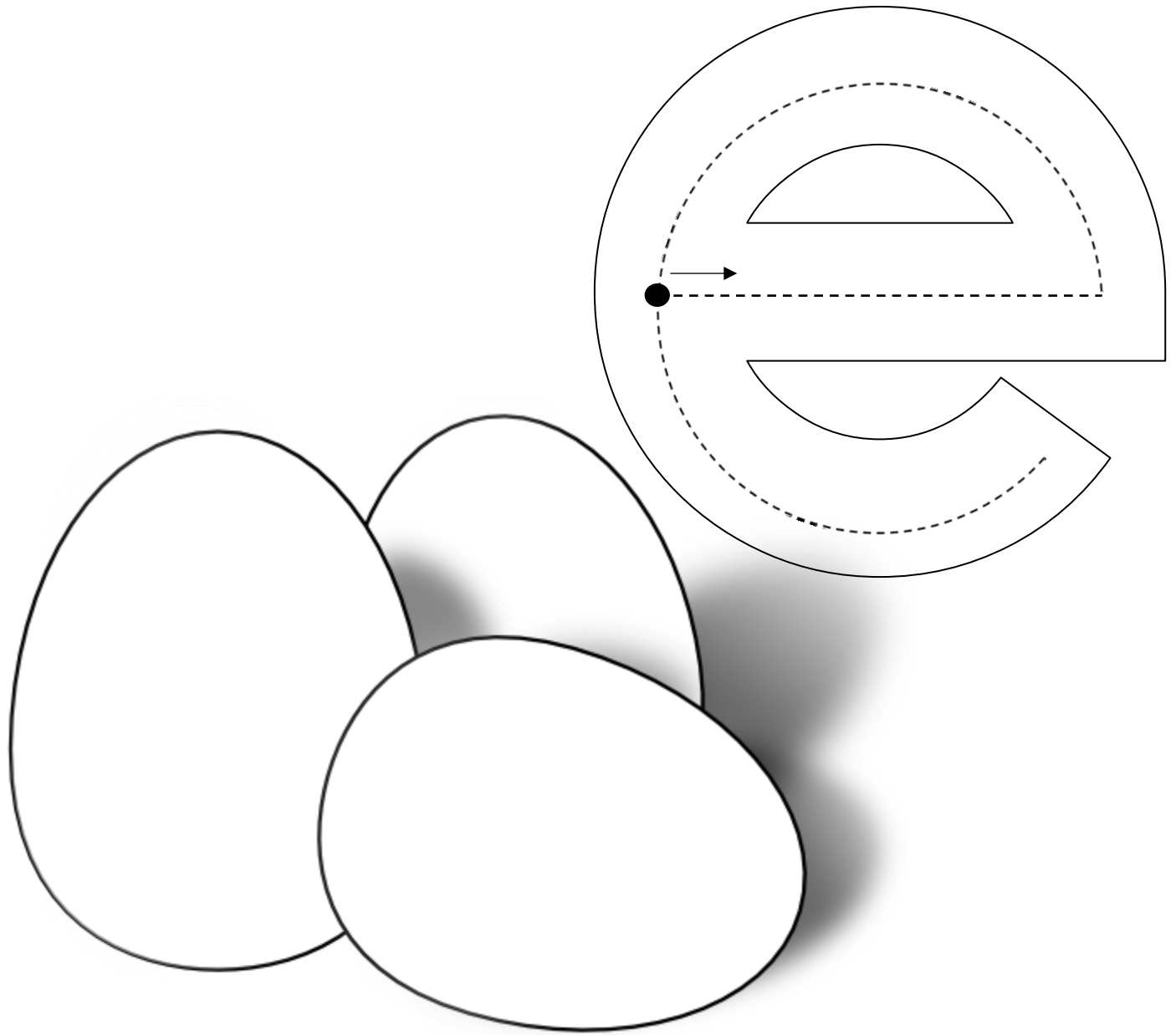

e gg

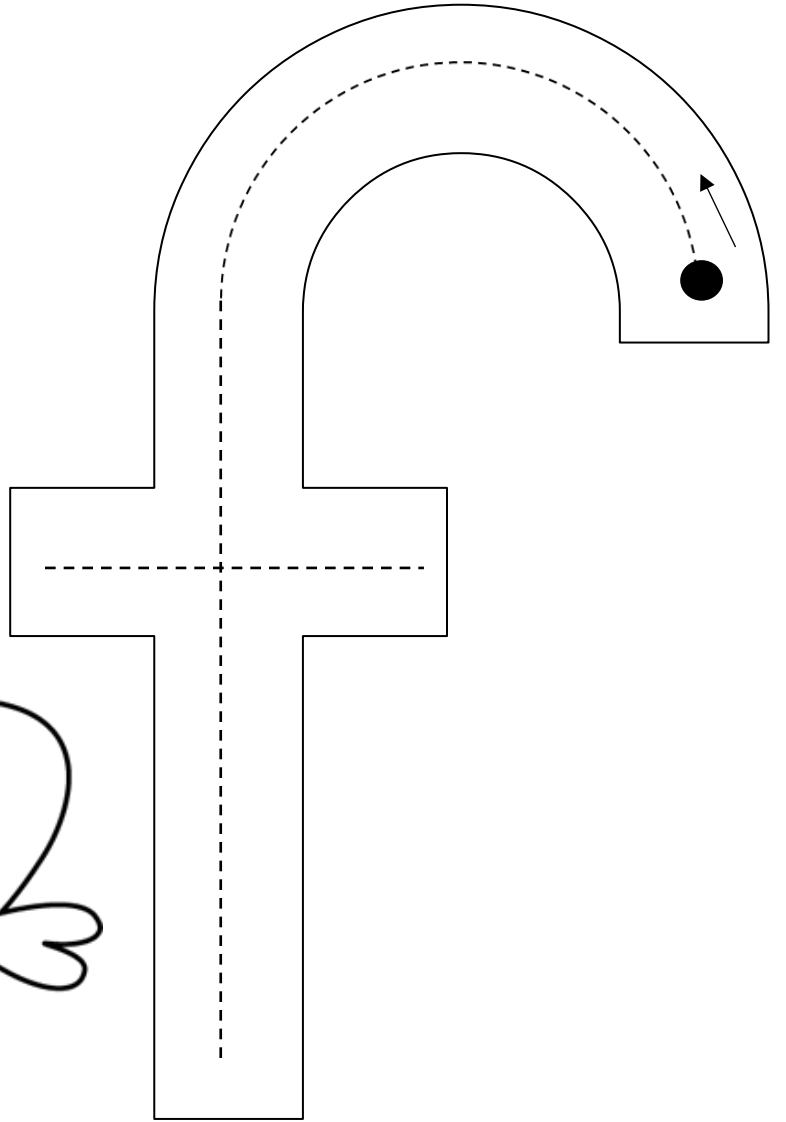
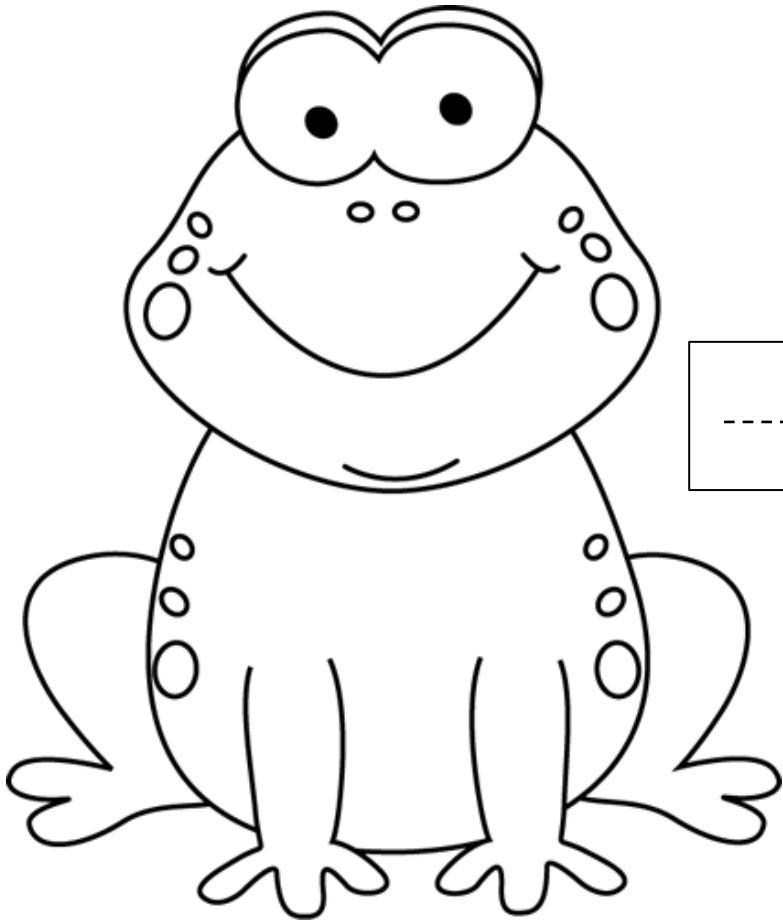

f r o g

How many
apples are
there?

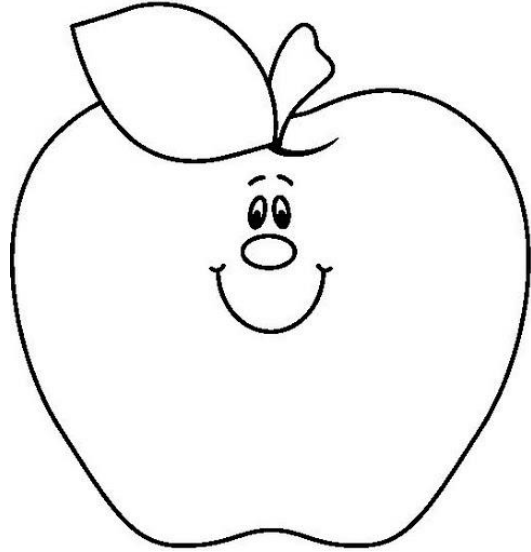
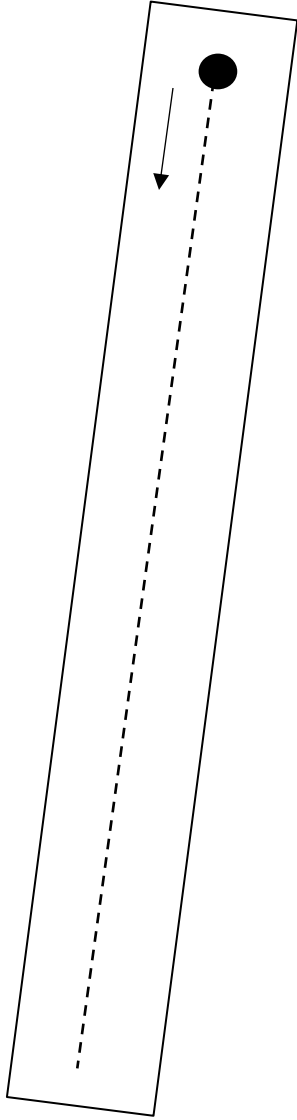

one

|||||

How many apples
are there?

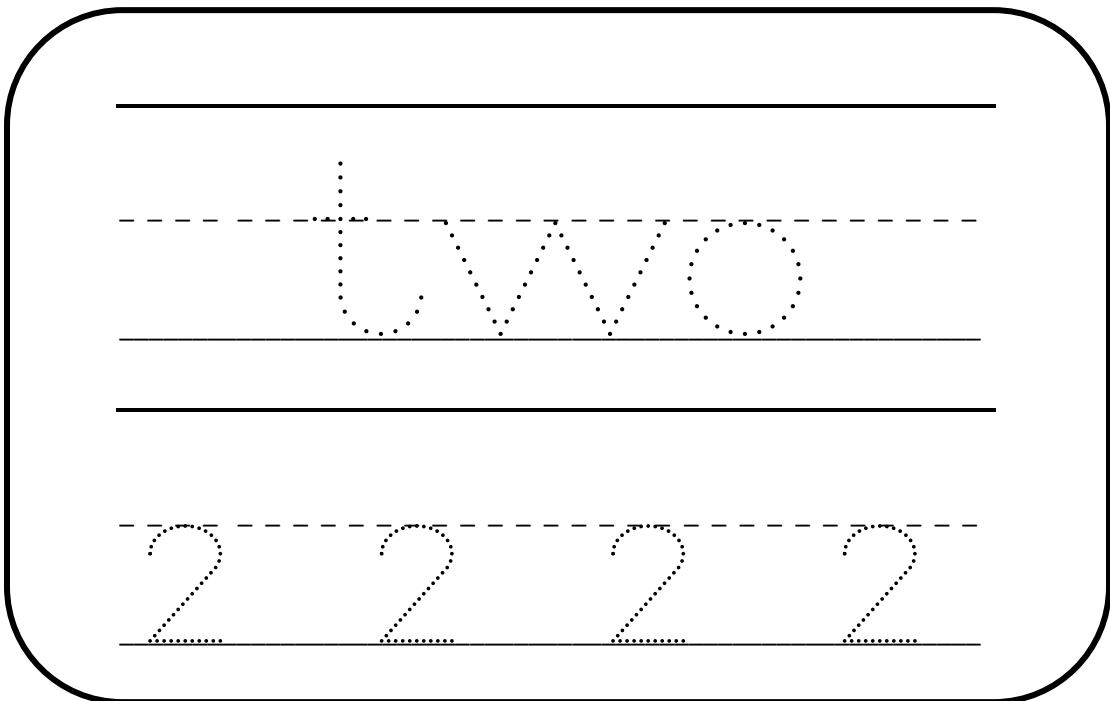
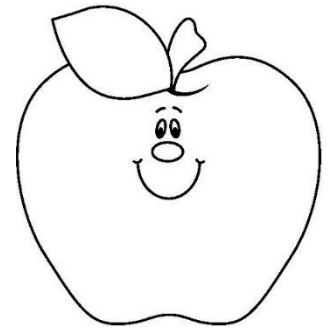
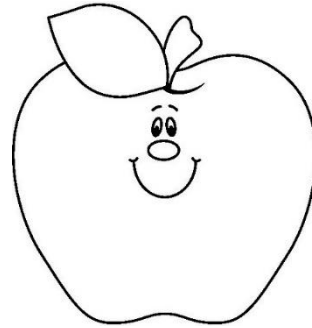
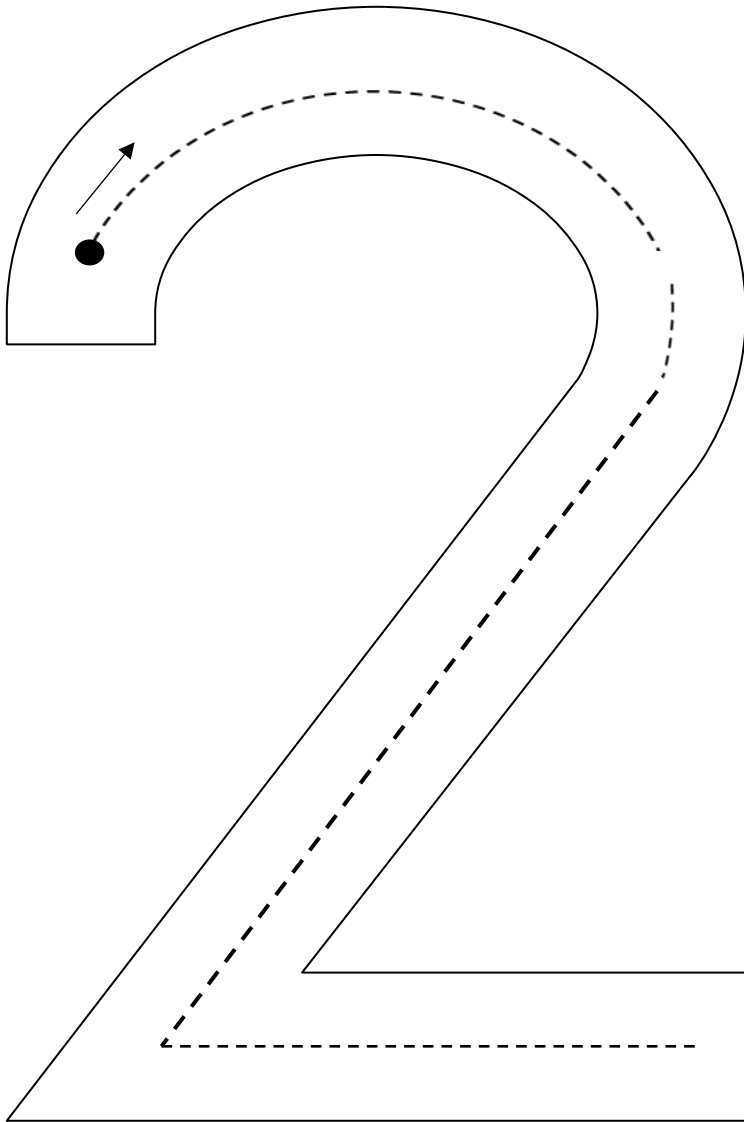

How many apples
are there?

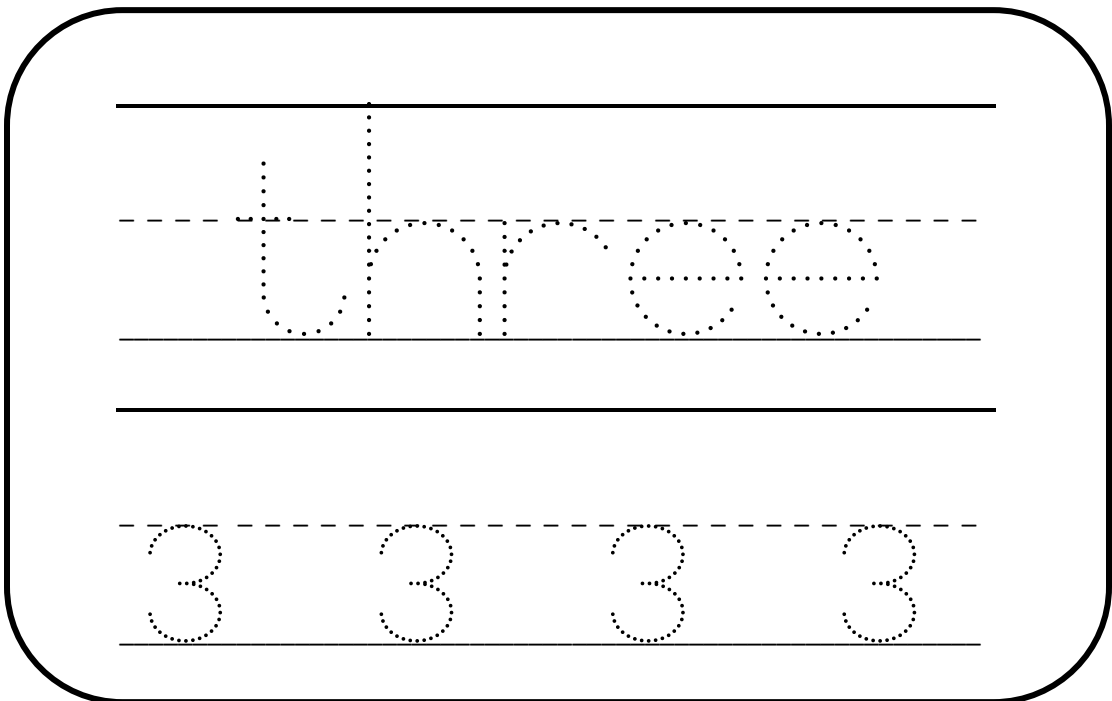
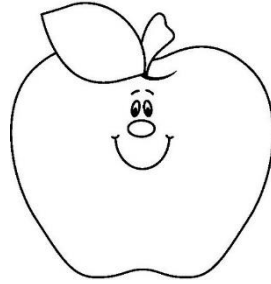
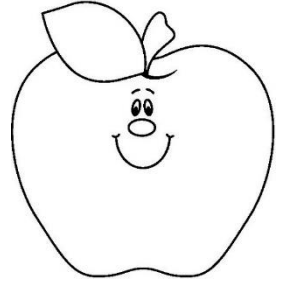
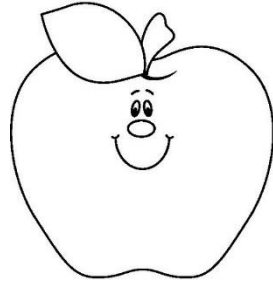
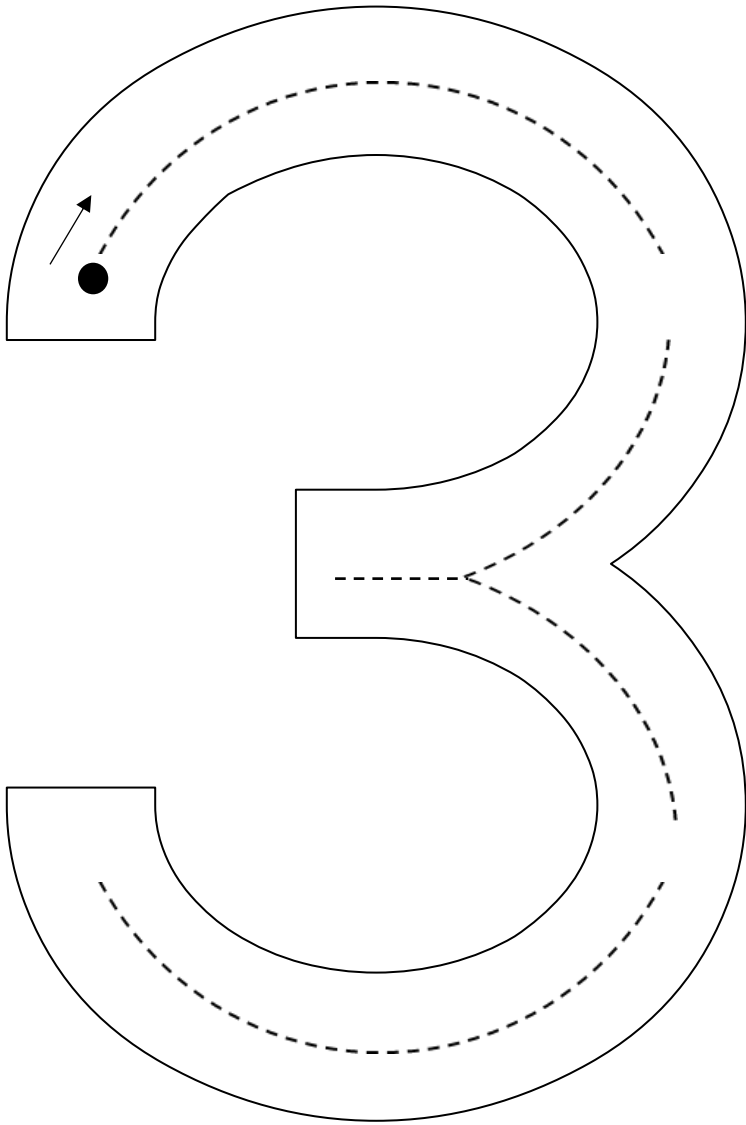

How many apples are there?

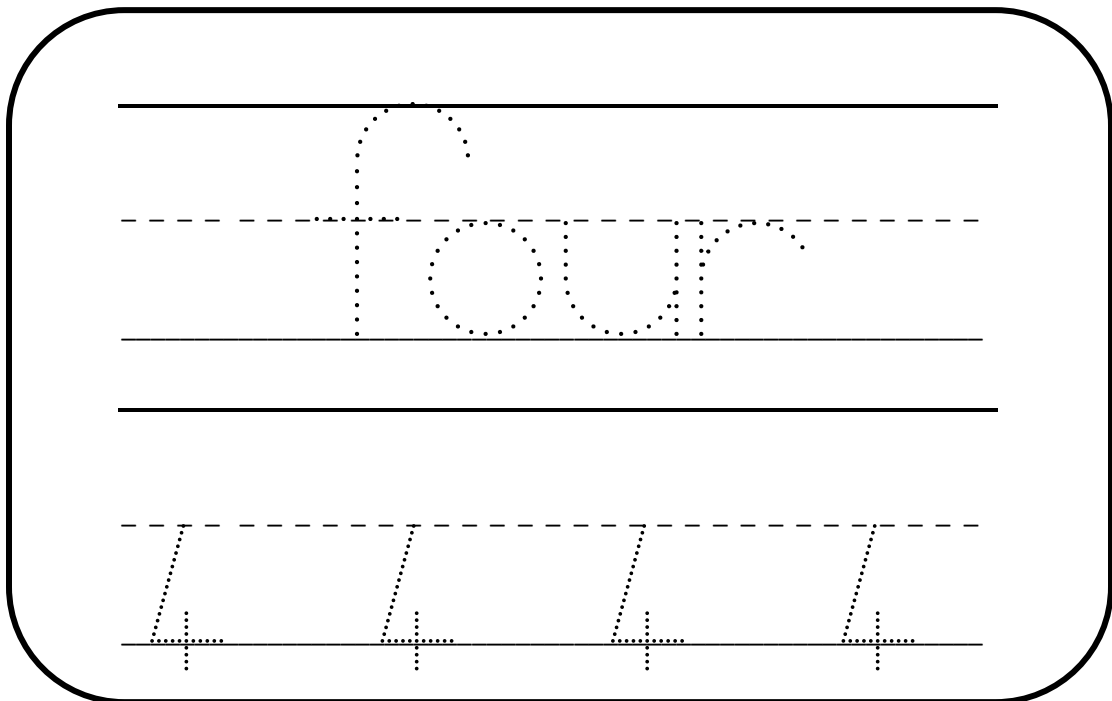
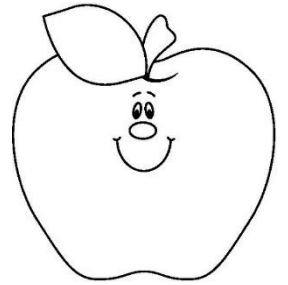
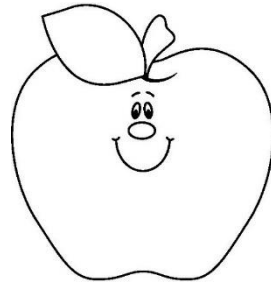
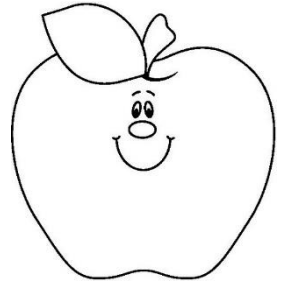
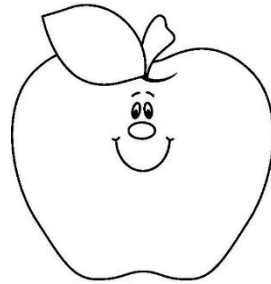
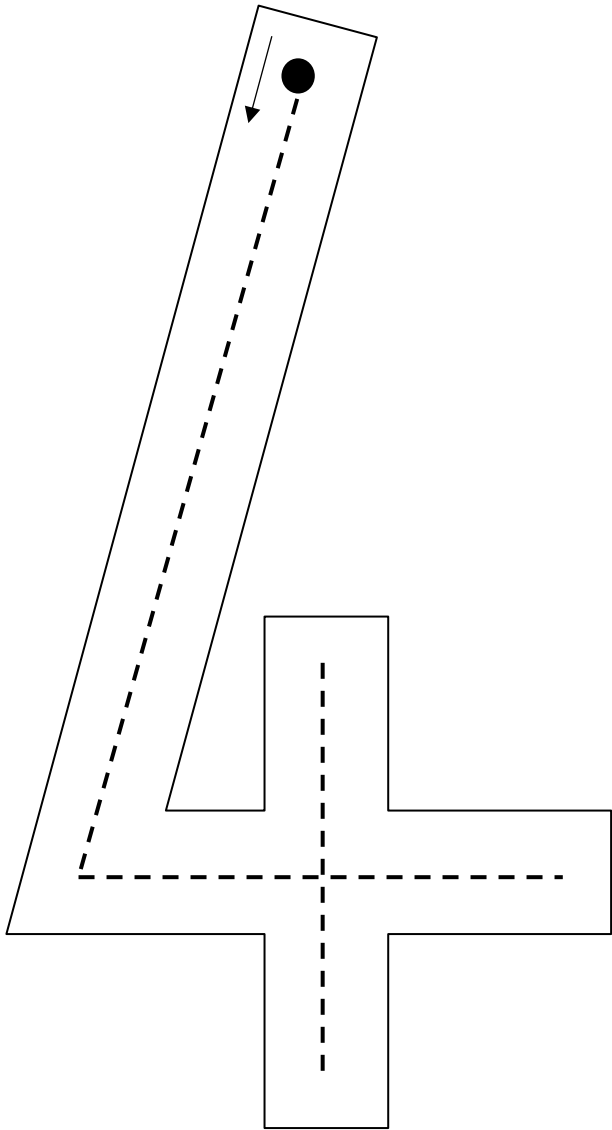

How many apples
are there?

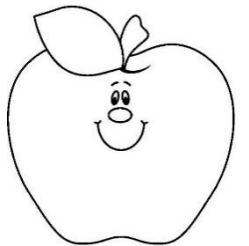
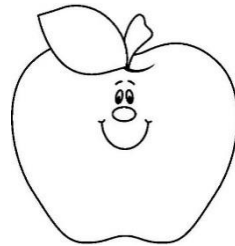
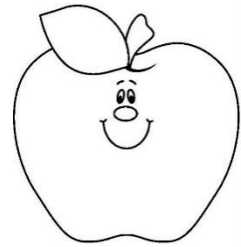
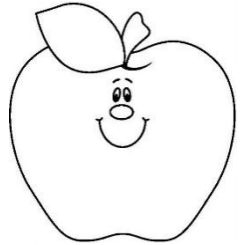
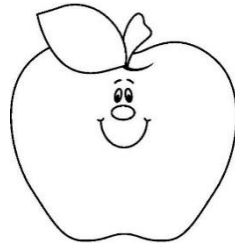
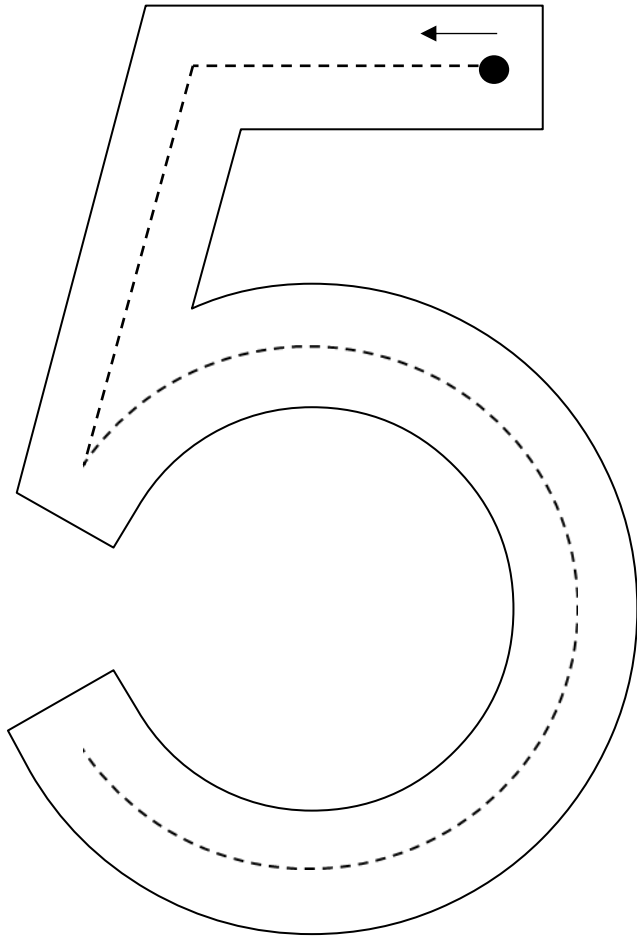

five

5 5 5 5

I know my colors!

Trace the words and colour the pictures the correct colour.

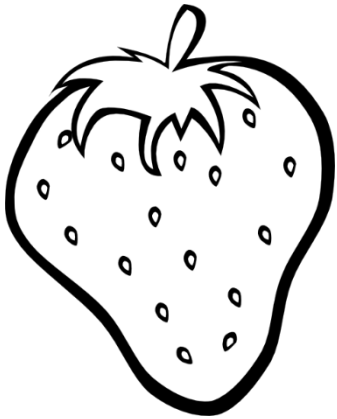

red

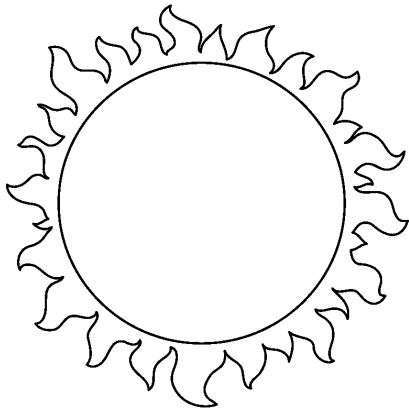

yellow

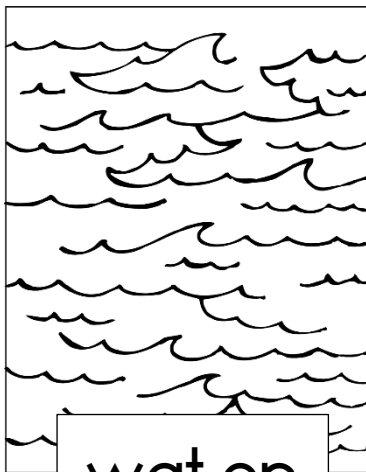

water

blue

The leaf is

green

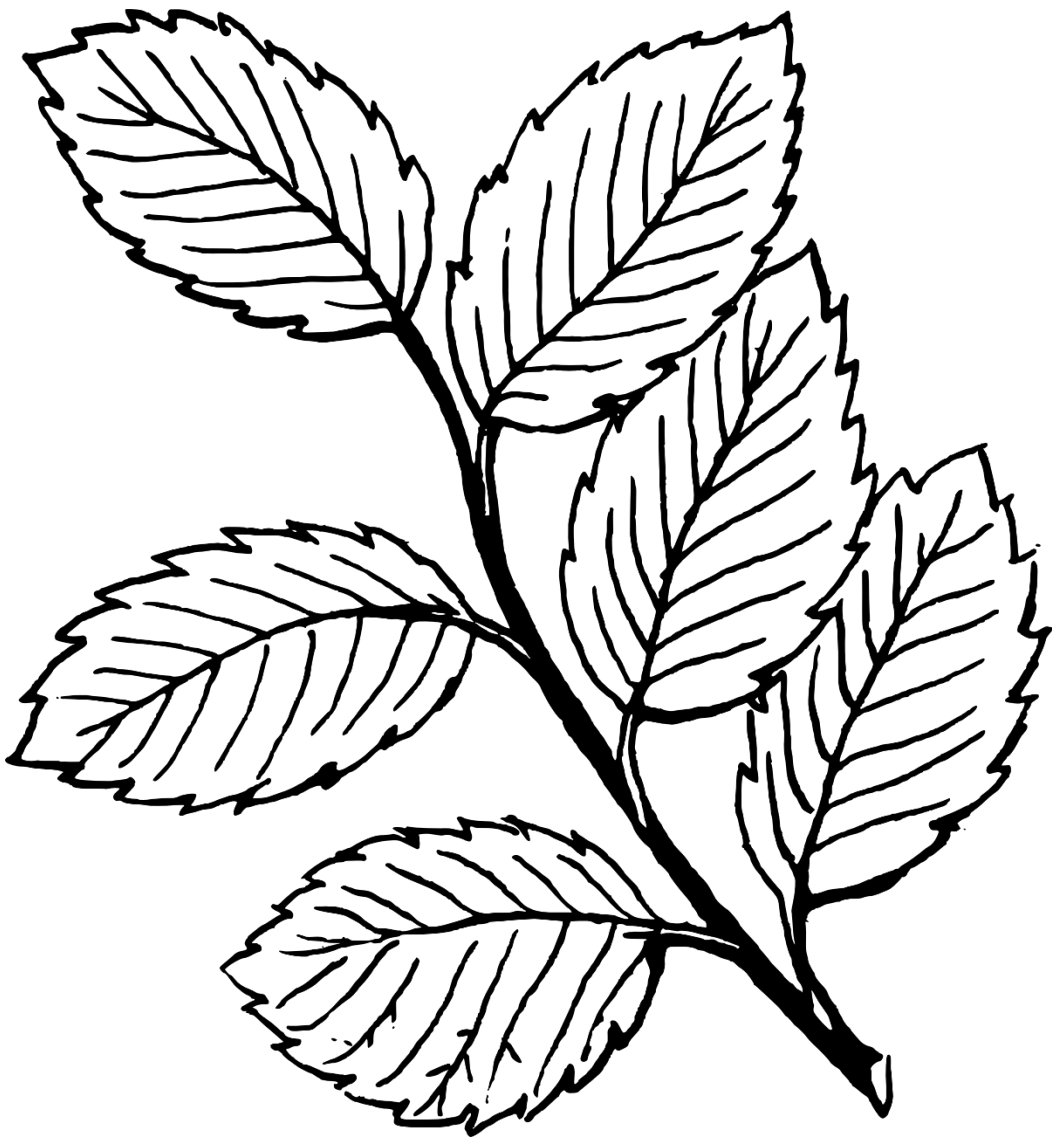

The orange

is orange

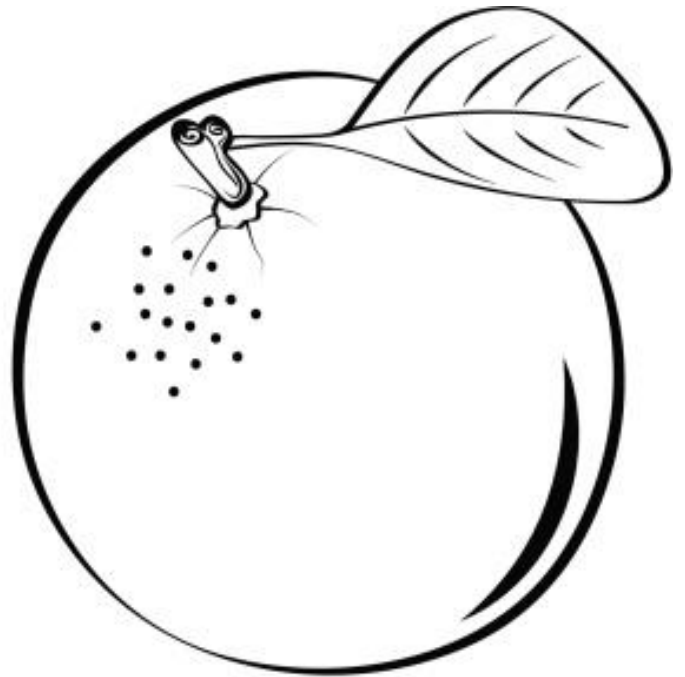
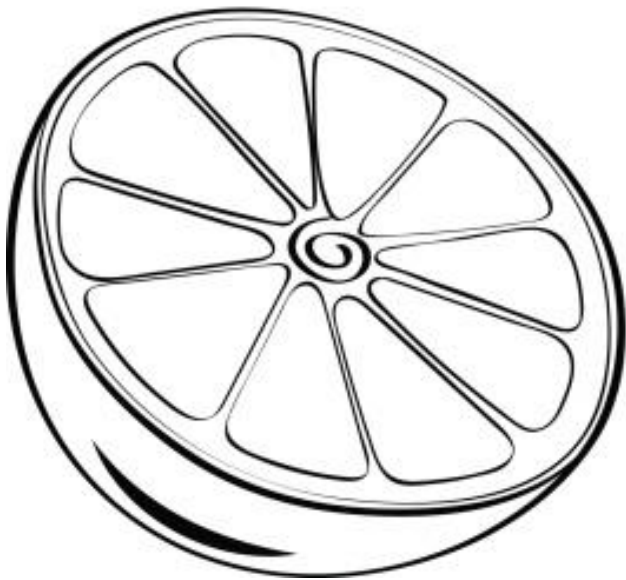



FINGERPAINT

The following activities is done by finger painting. The child must dip the tip off their finger into the paint and complete the activities.

Make a body for the
Worm.

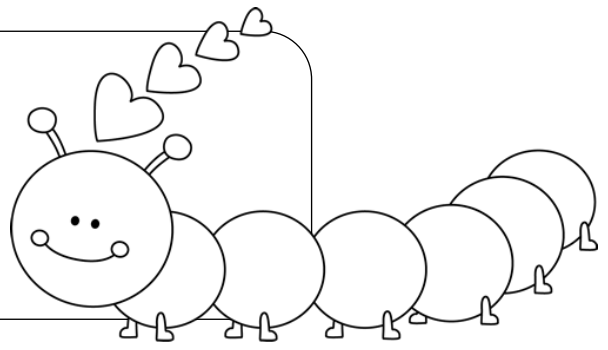

4		
1		
3		
5		
2		
6		

Give the flowers
petals.

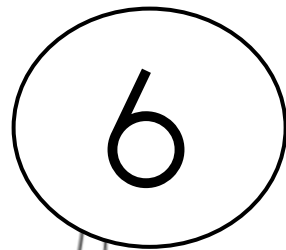
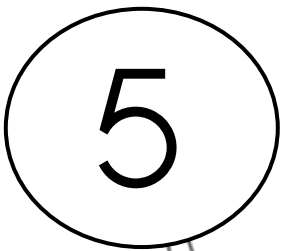
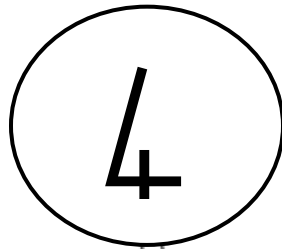

Dip your finger into the paint
to form the letters

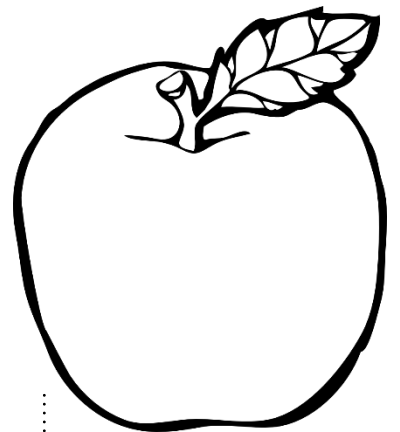
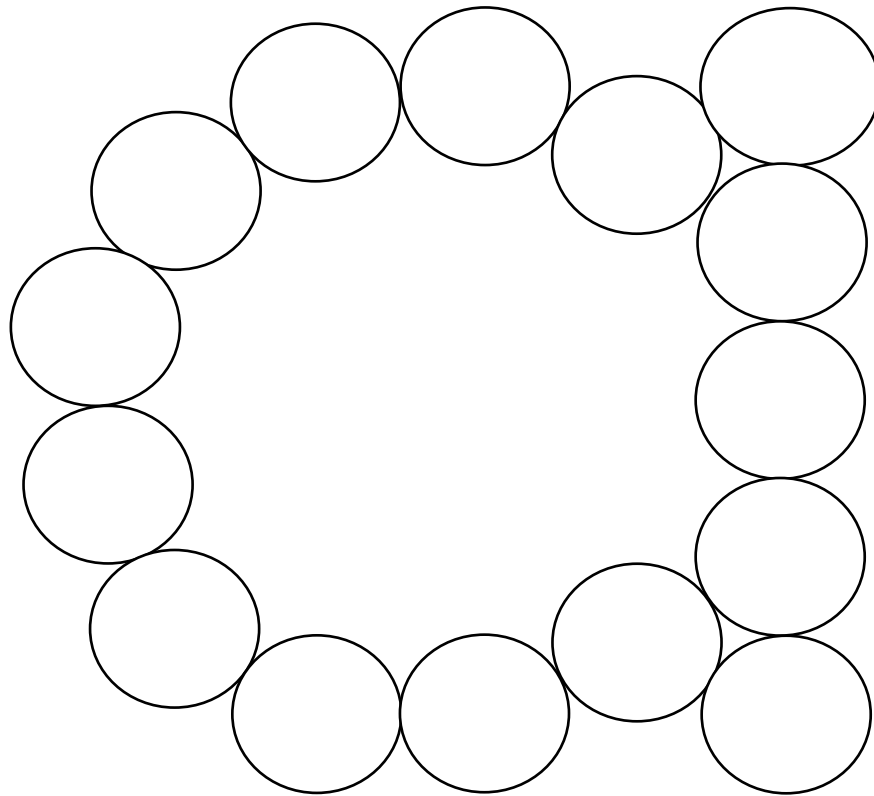

a is for

apple

Dip your finger into the paint to form the letters

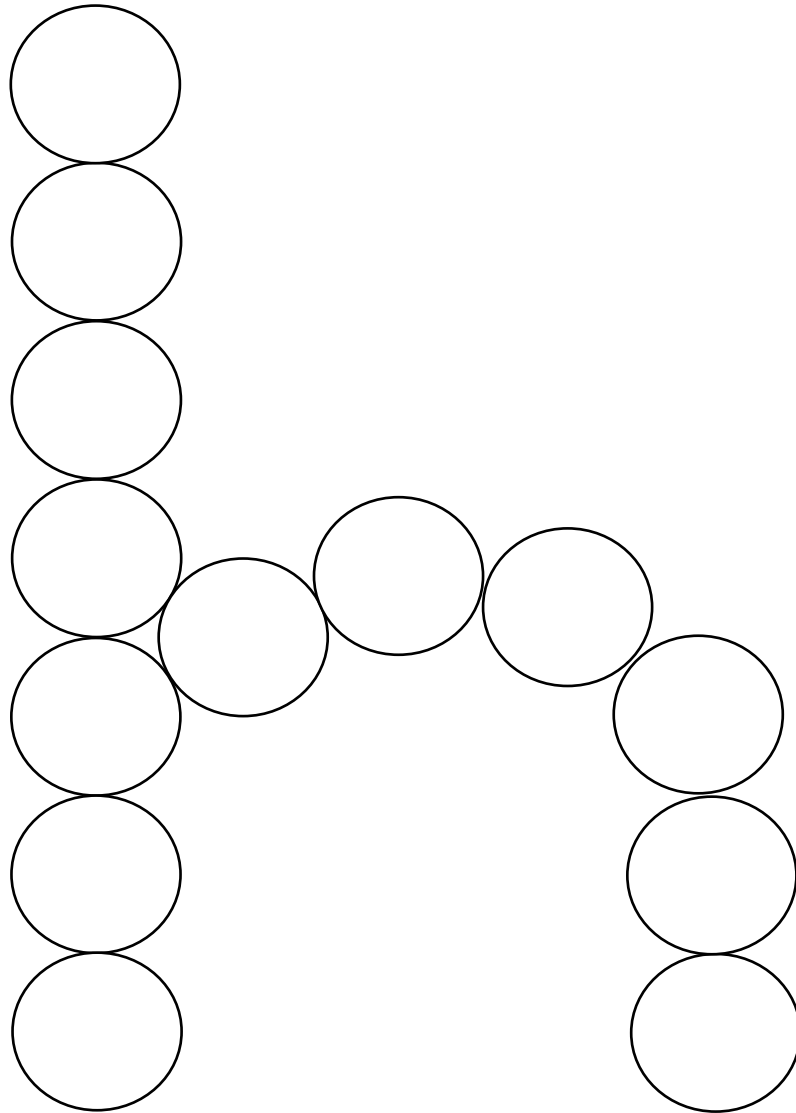

h is for

horse

Dip your finger into the paint to form the letters

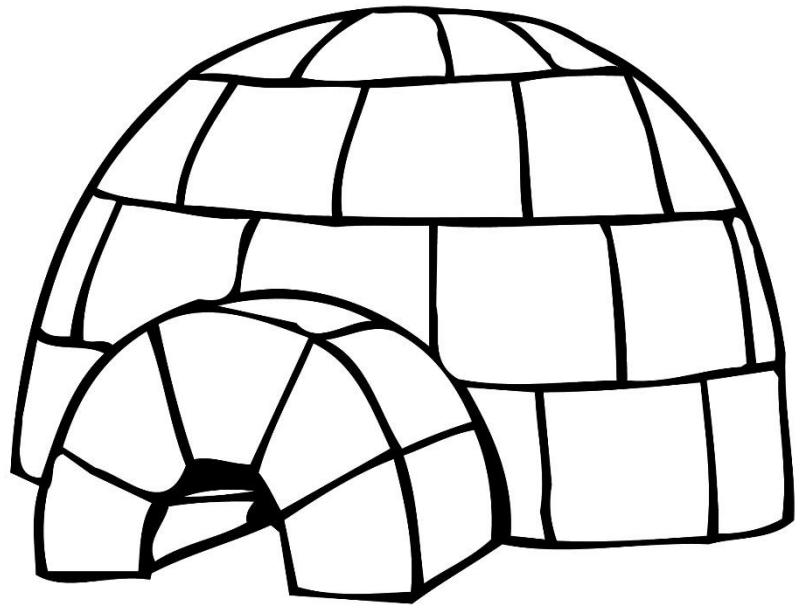
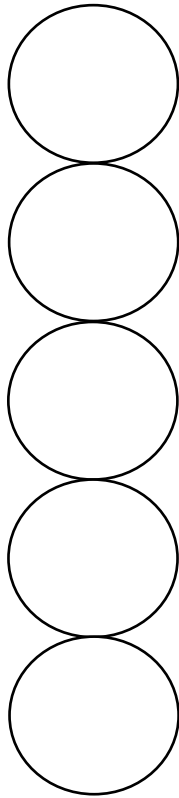
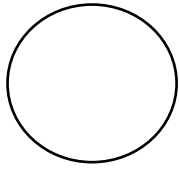

i is for igloo

Dip your finger into the paint to form the letters

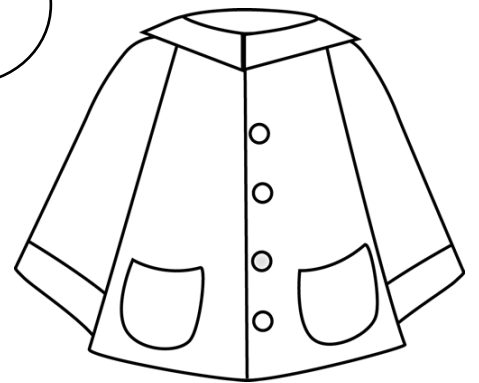
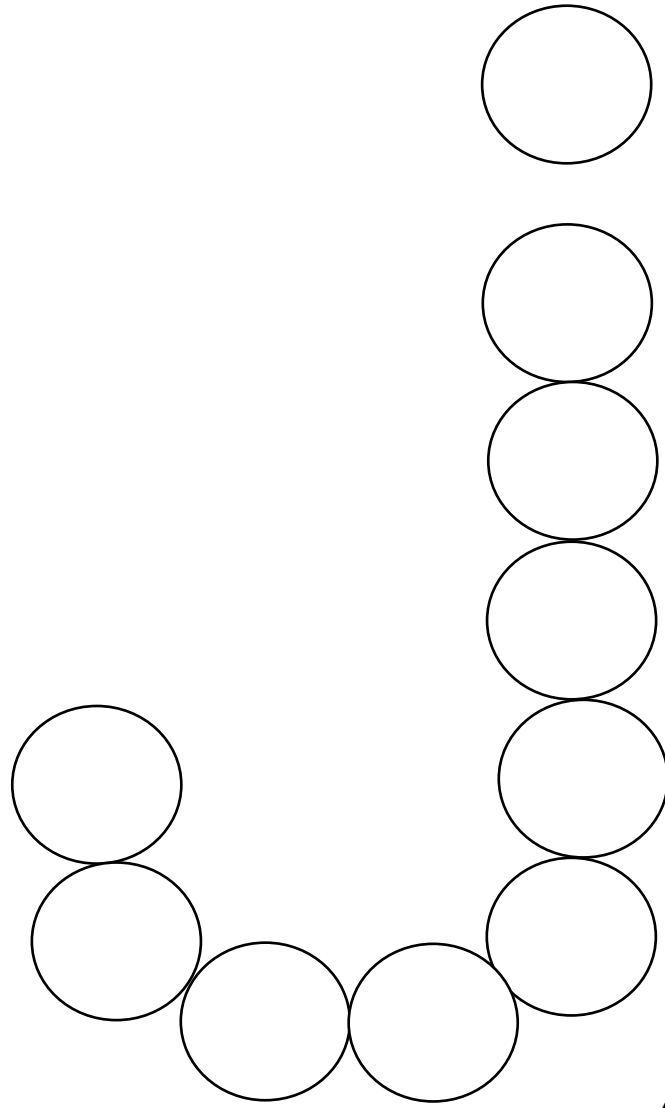

j is for

jacket

Dip your finger into the
paint to form the letters

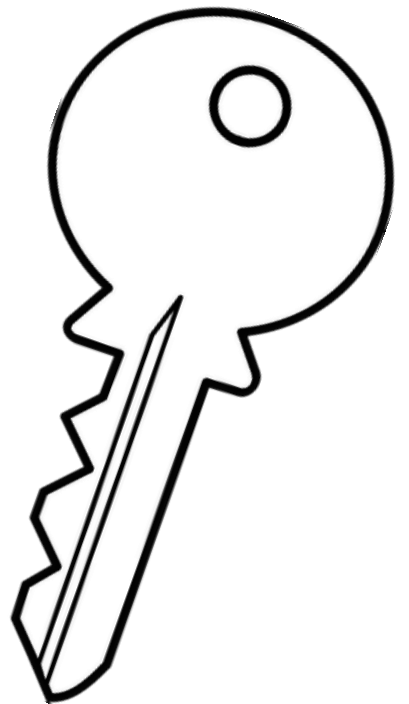
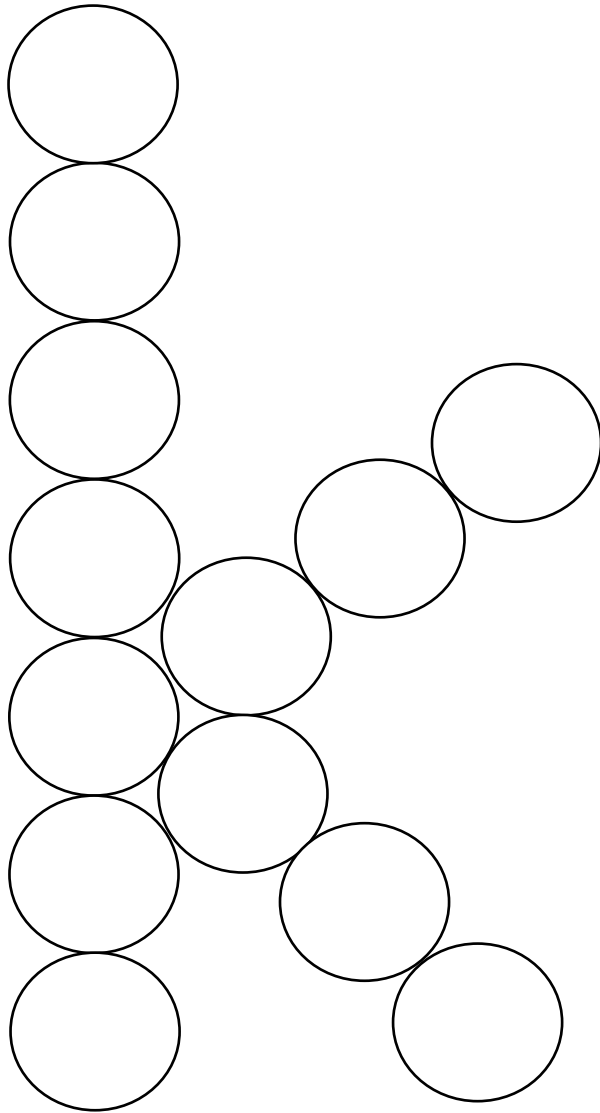

k is for **key**

Dip your finger into the
paint to form the letters

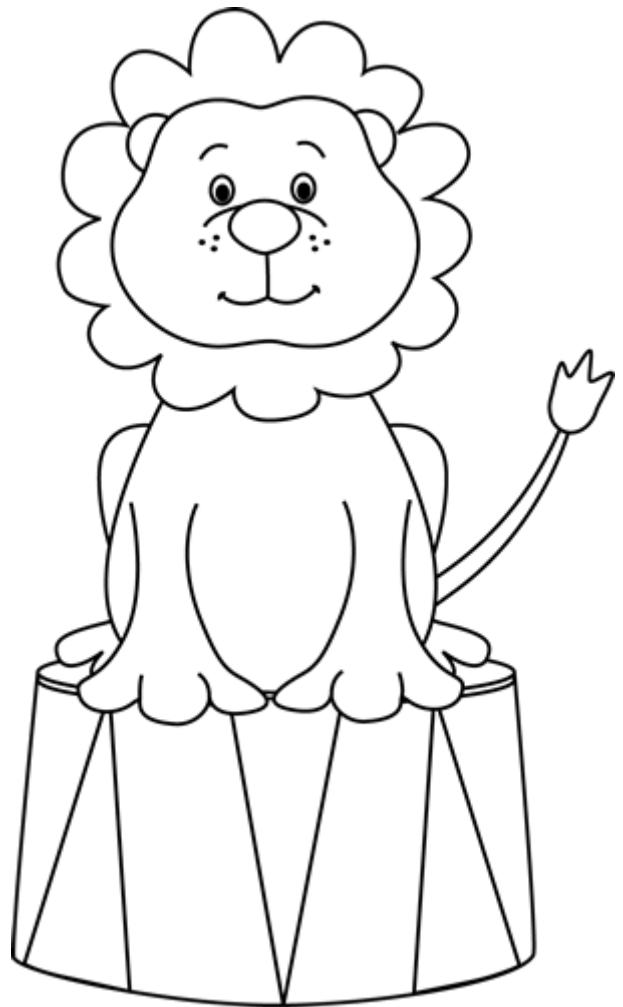
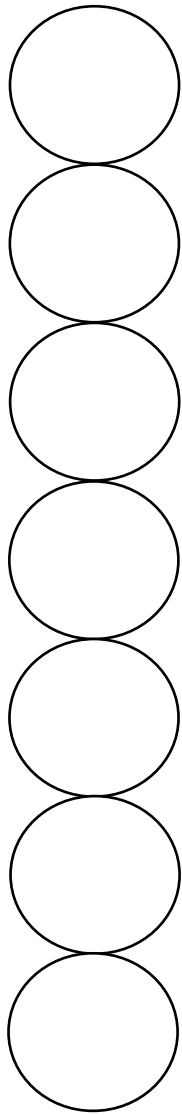

l is for lion