

GRAAD 3

Wiskunde

Kwartaal 2

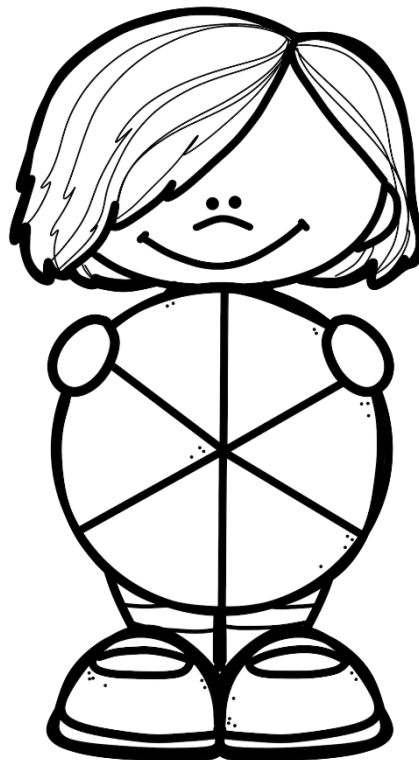
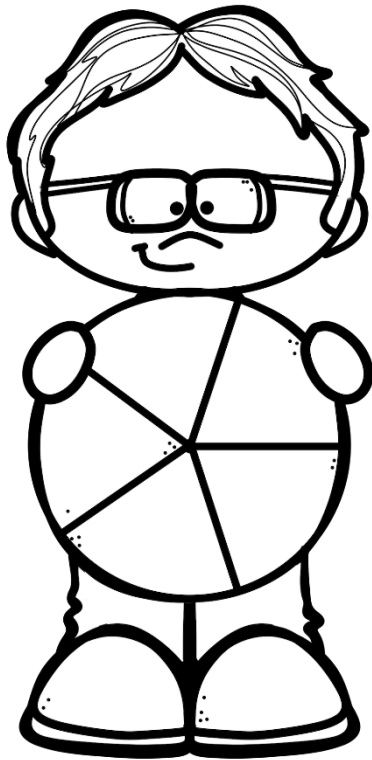

Naam:

Groepe

Tel die aarbeie in die mandjies deur groepering.

Skryf dan 'n getalsin vir elk van die volgende:

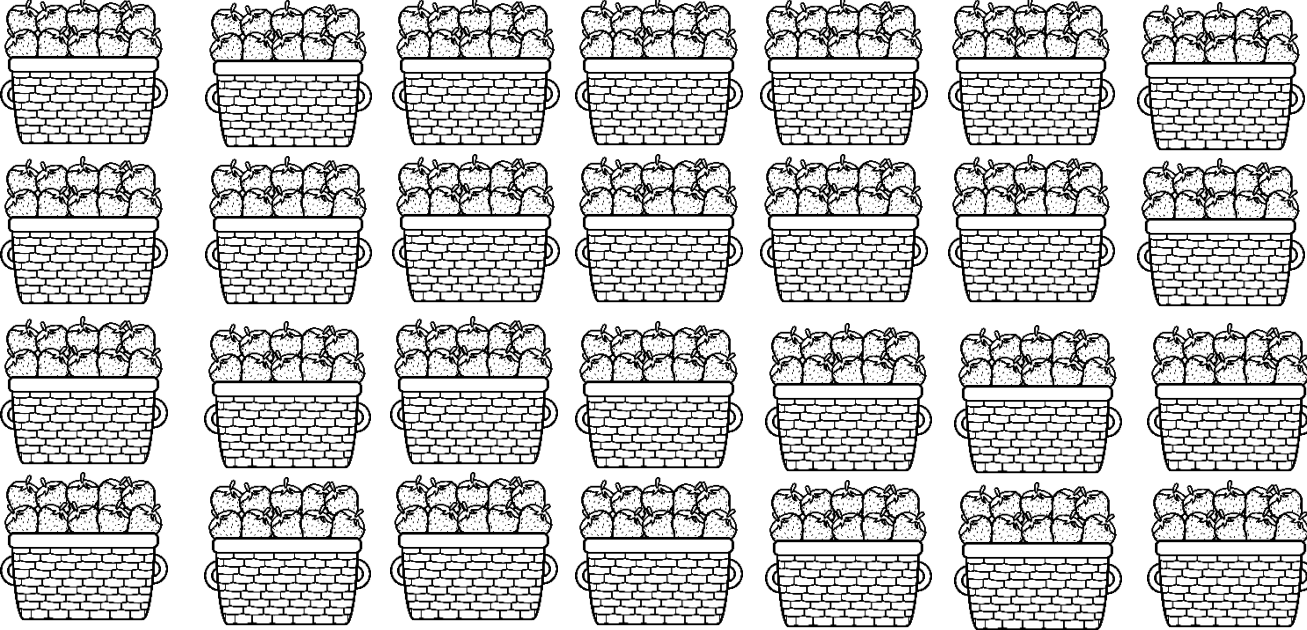

_____ groepe van _____ = _____ aarbeie

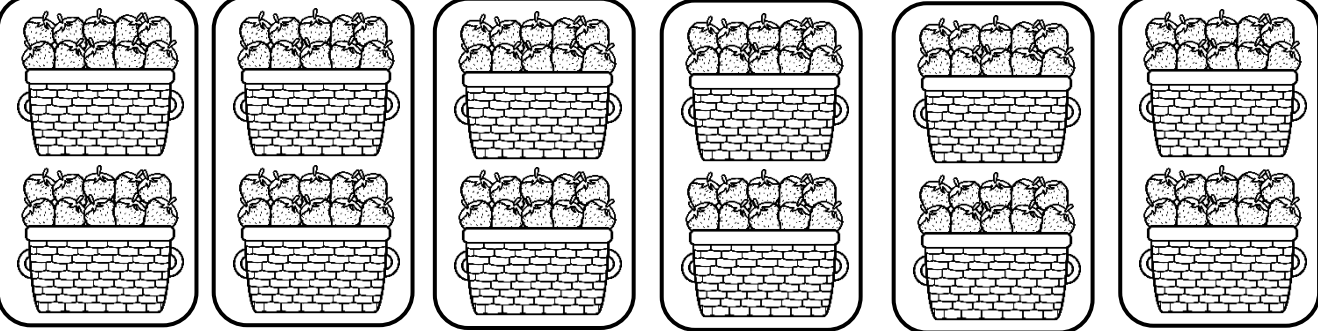

_____ groepe van _____ = _____ aarbeie

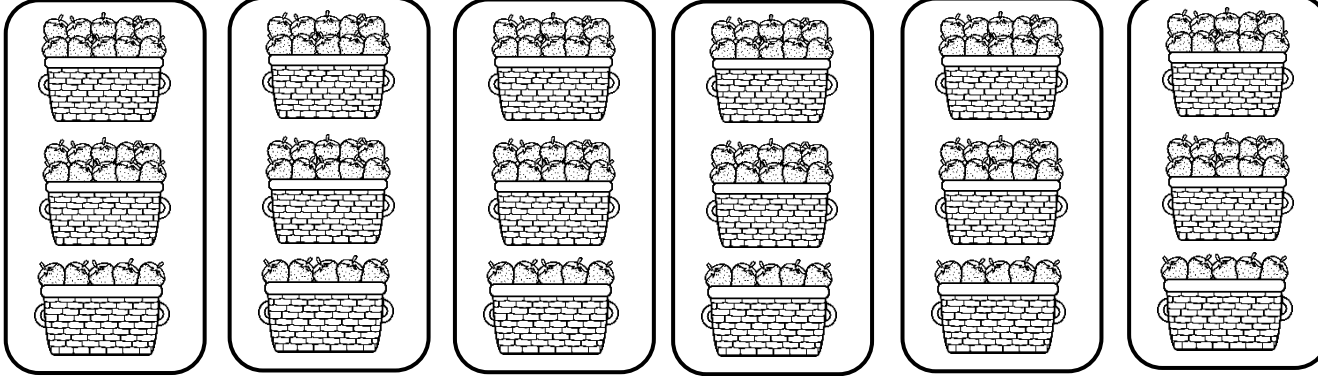

_____ groepe van _____ = _____ aarbeie

Groepe van 3

Tel die piesangs deur groepering.

Skryf dan 'n getalsin vir elk van die volgende:

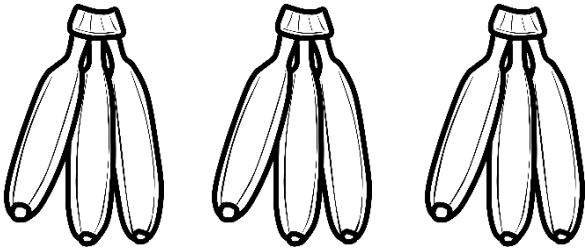

_____ = _____ piesangs
_____ groepe van _____ = _____ piesangs

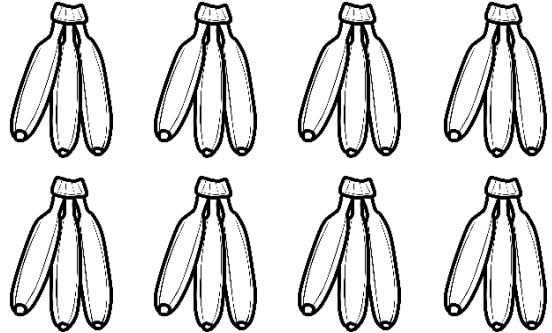

_____ = _____ piesangs
_____ groepe van _____ = _____ piesangs

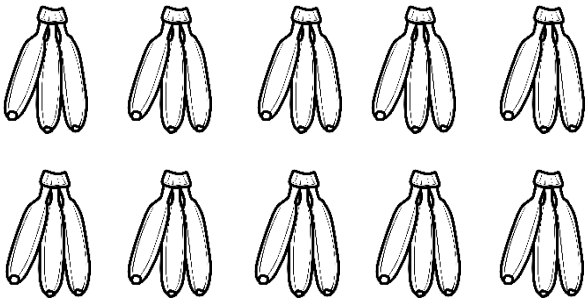

_____ = _____ piesangs
_____ groepe van _____ = _____ piesangs

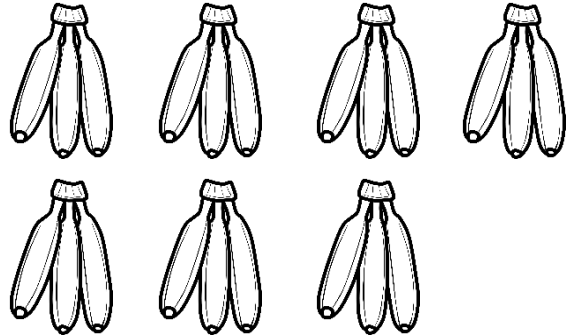

_____ = _____ piesangs
_____ groepe van _____ = _____ piesangs

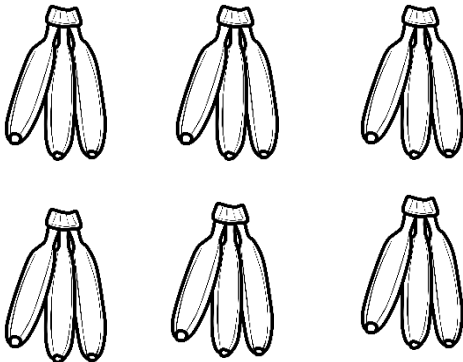

_____ = _____ piesangs
_____ groepe van _____ = _____ piesangs

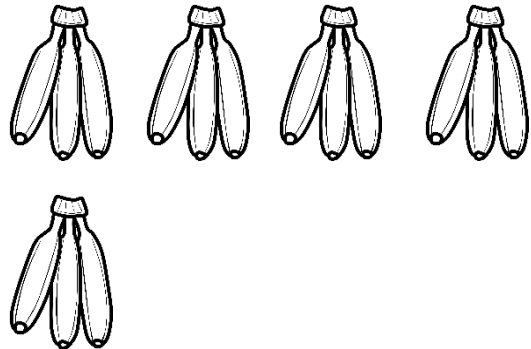

_____ = _____ piesangs
_____ groepe van _____ = _____ piesangs

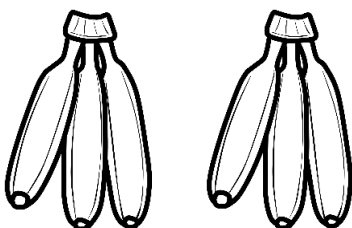

_____ = _____ piesangs
_____ groepe van _____ = _____ piesangs

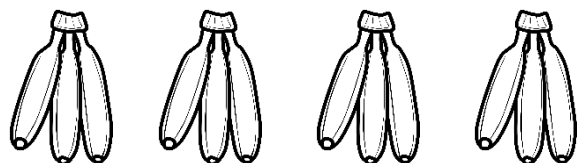

_____ = _____ piesangs
_____ groepe van _____ = _____ piesangs

Groepe van 4

Tel die piesangs deur groepering.

Skryf dan 'n getalsin vir elk van die volgende:

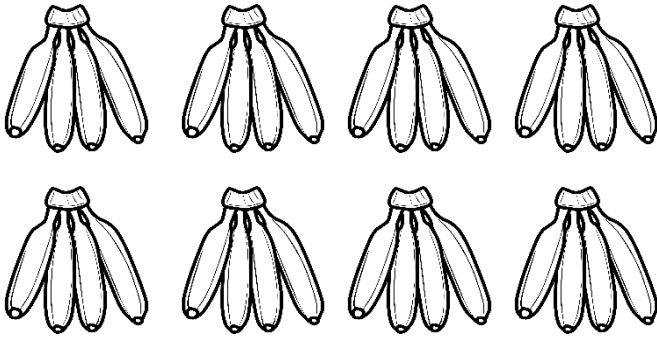

_____ = _____ piesangs
_____ groepe van _____ = _____ piesangs

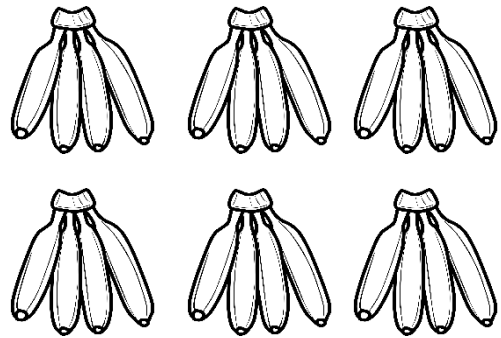

_____ = _____ piesangs
_____ groepe van _____ = _____ piesangs

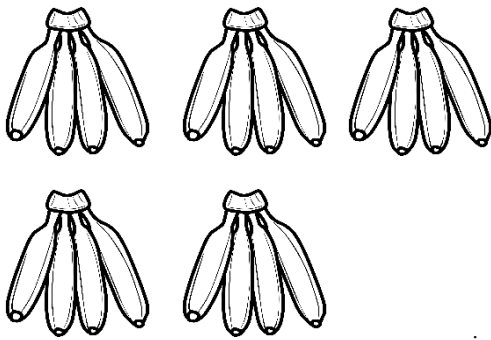

_____ = _____ piesangs
_____ groepe van _____ = _____ piesangs

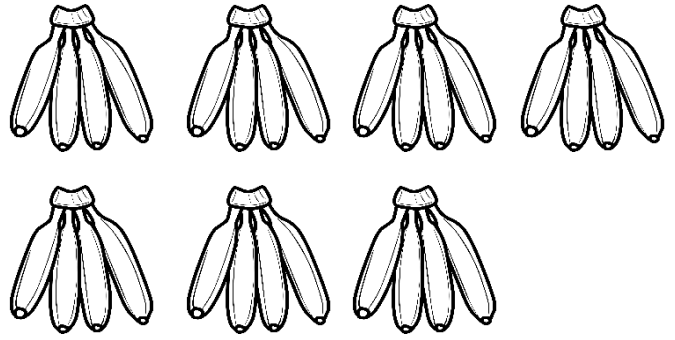

_____ = _____ piesangs
_____ groepe van _____ = _____ piesangs

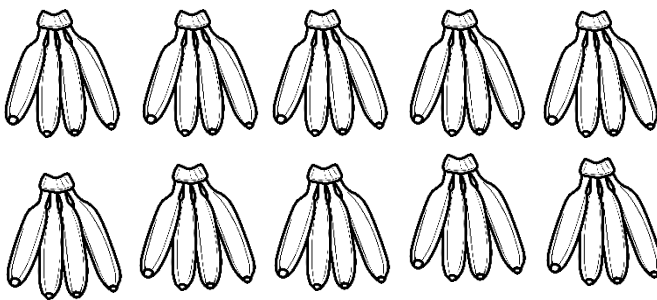

_____ = _____ piesangs
_____ groepe van _____ = _____ piesangs

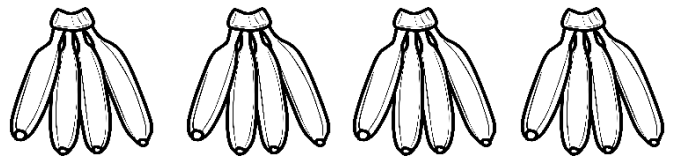

_____ = _____ piesangs
_____ groepe van _____ = _____ piesangs

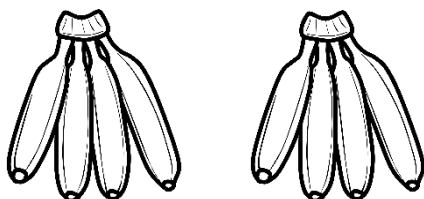

_____ = _____ piesangs
_____ groepe van _____ = _____ piesangs

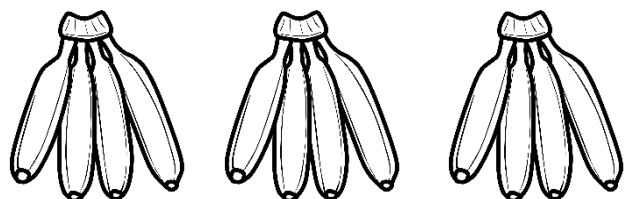

_____ = _____ piesangs
_____ groepe van _____ = _____ piesangs

Groepe van 5

Tel die aarbeie in die mandjies deur groepering.

Skryf dan 'n getalsin vir elk van die volgende:

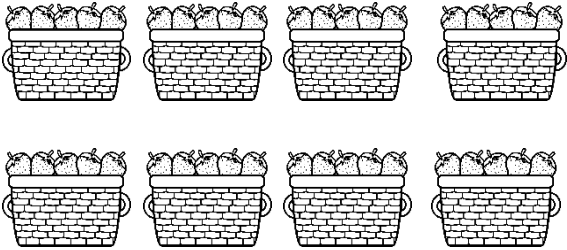

_____ = _____ aarbeie
_____ groepe van _____ = _____ aarbeie

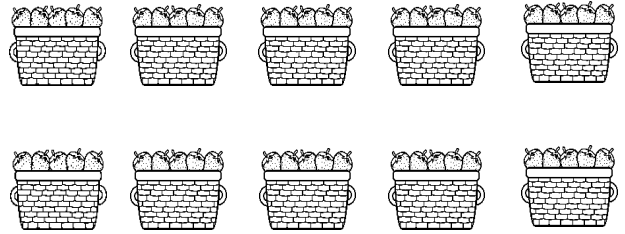

_____ = _____ aarbeie
_____ groepe van _____ = _____ aarbeie

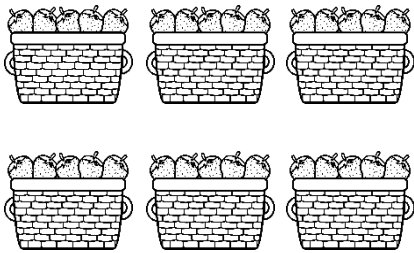

_____ = _____ aarbeie
_____ groepe van _____ = _____ aarbeie

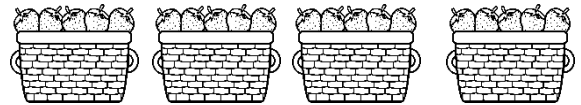

_____ = _____ aarbeie
_____ groepe van _____ = _____ aarbeie

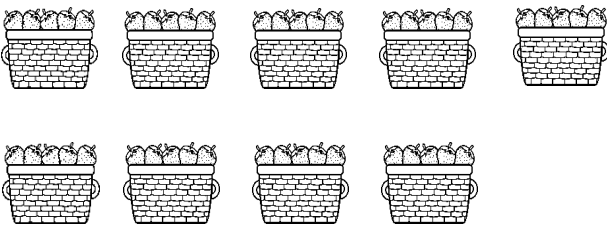

_____ = _____ aarbeie
_____ groepe van _____ = _____ aarbeie

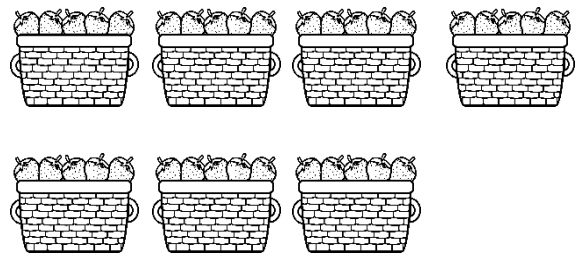

_____ = _____ aarbeie
_____ groepe van _____ = _____ aarbeie

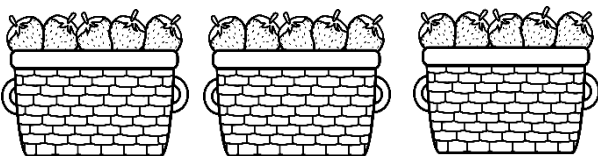

_____ = _____ aarbeie
_____ groepe van _____ = _____ aarbeie

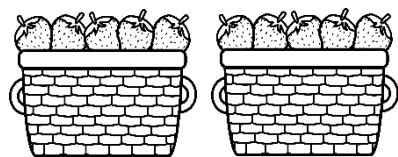

_____ = _____ aarbeie
_____ groepe van _____ = _____ aarbeie

Groep van 6

Tel die aarbeie in die mandjies deur groepering.

Skryf dan 'n getalsin vir elk van die volgende:

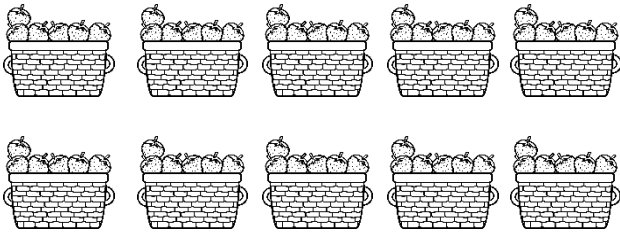

_____ = _____ aarbeie
_____ groepe van _____ = _____ aarbeie

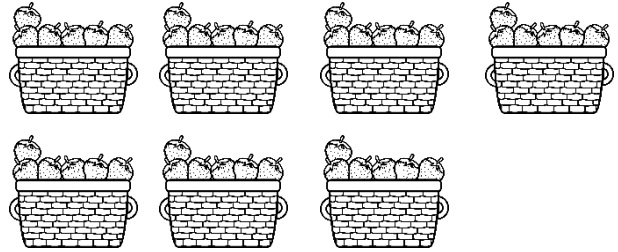

_____ = _____ aarbeie
_____ groepe van _____ = _____ aarbeie

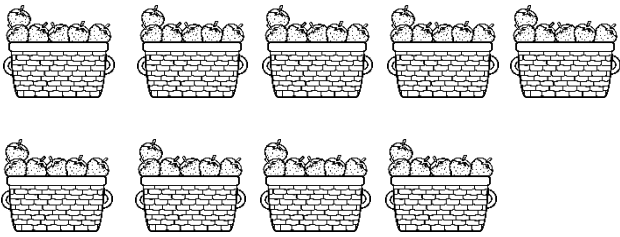

_____ = _____ aarbeie
_____ groepe van _____ = _____ aarbeie

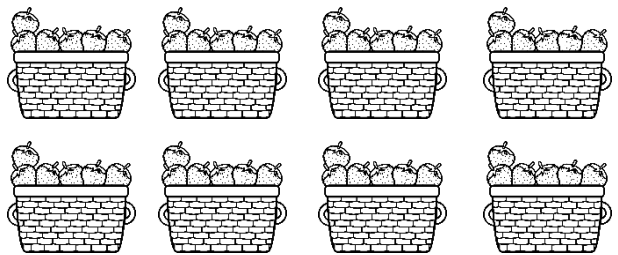

_____ = _____ aarbeie
_____ groepe van _____ = _____ aarbeie

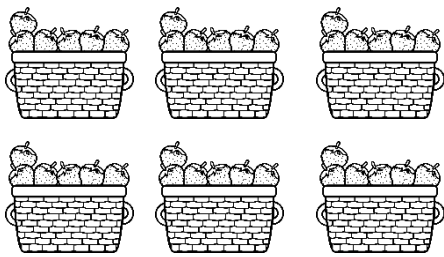

_____ = _____ aarbeie
_____ groepe van _____ = _____ aarbeie

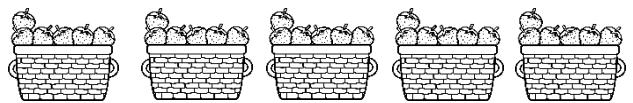

_____ = _____ aarbeie
_____ groepe van _____ = _____ aarbeie

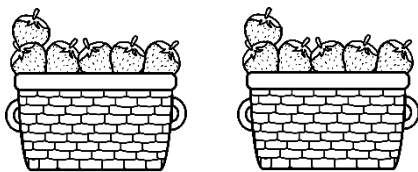

_____ = _____ aarbeie
_____ groepe van _____ = _____ aarbeie

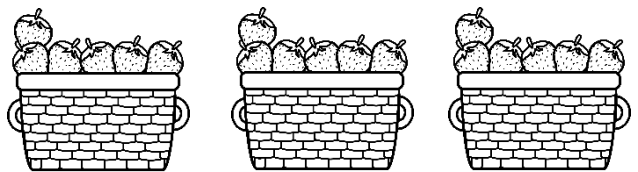

_____ = _____ aarbeie
_____ groepe van _____ = _____ aarbeie

Groepe

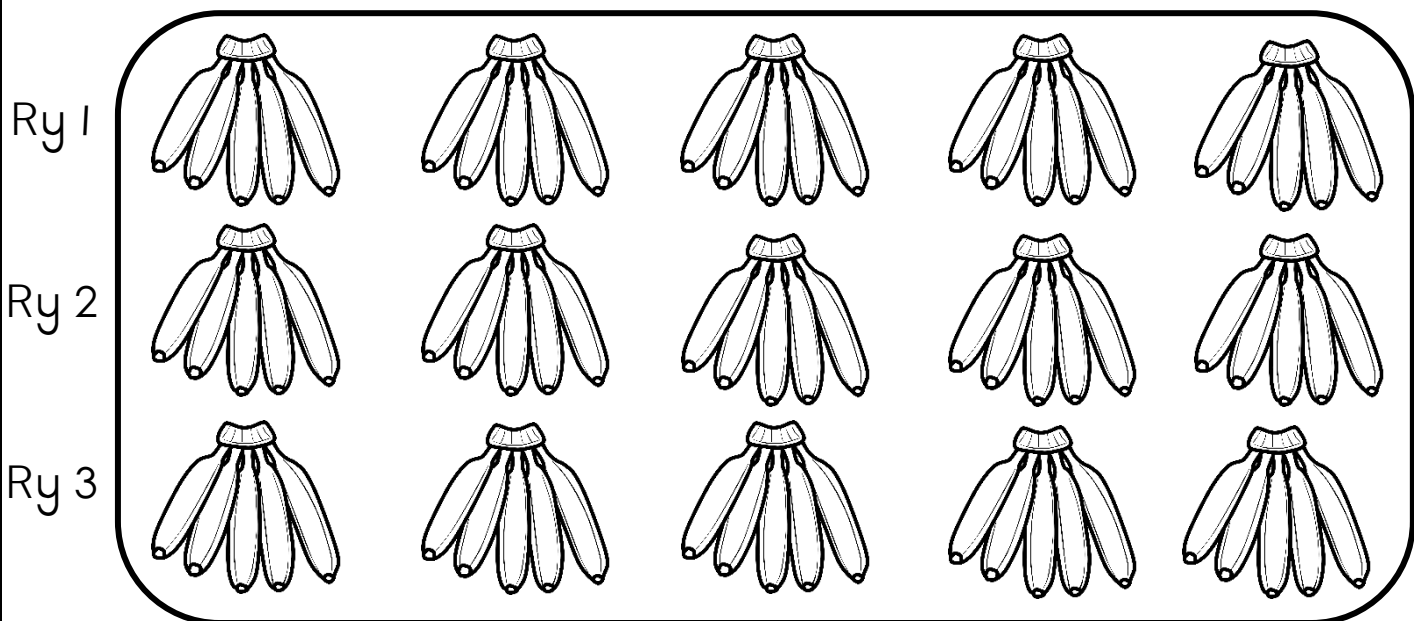

1. Hoeveel piesangs is in 'n tros? _____
2. Hoeveel trosse piesangs is in elke ry? _____
3. Hoeveel piesangs is in elke ry? _____
4. Hoeveel piesangs is daar altesaam? _____
5. Skryf 'n getalsin wat die totale aantal piesangs aandui.

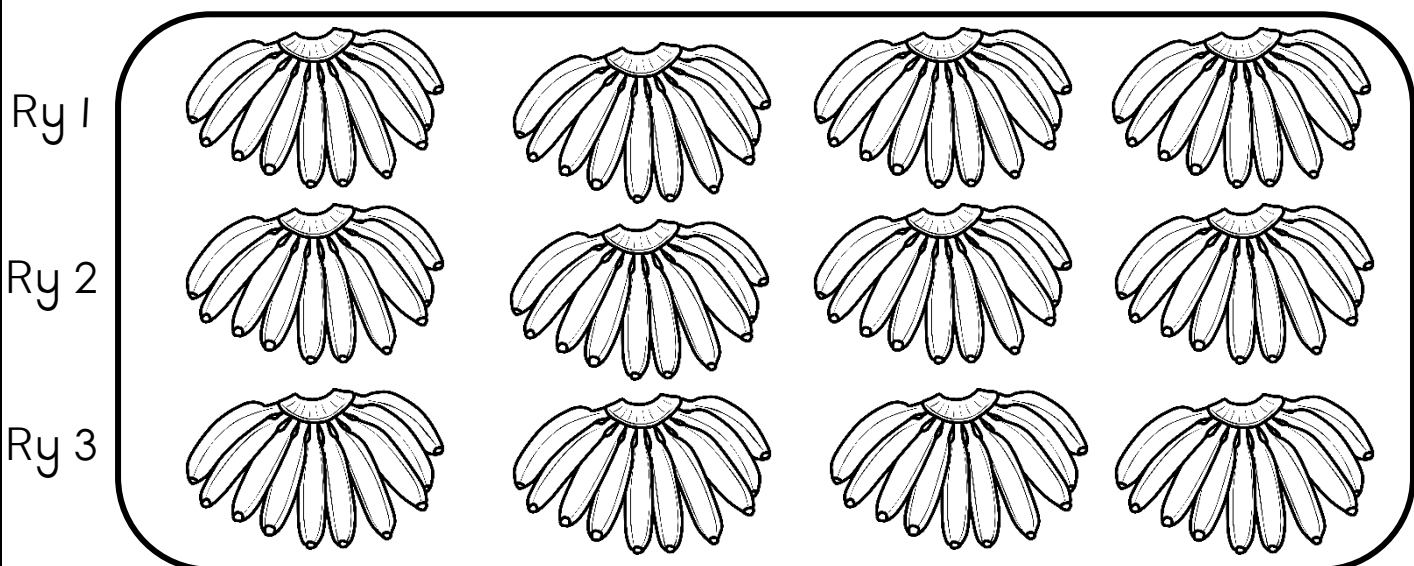

1. Hoeveel piesangs is in 'n tros? _____
2. Hoeveel trosse piesangs is in elke ry? _____
3. Hoeveel piesangs is in elke ry? _____
4. Hoeveel piesangs is daar altesaam? _____
5. Skryf 'n getalsin wat die totale aantal piesangs aandui.

Tel aan en terug

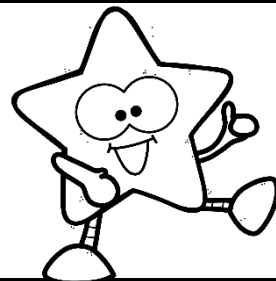

Tel vorentoe of agtertoe in 2's.

a.

246	248					258		
-----	-----	--	--	--	--	-----	--	--

b.

315	317						329	
-----	-----	--	--	--	--	--	-----	--

c.

197	199								
-----	-----	--	--	--	--	--	--	--	--

d.

460			400		360				
-----	--	--	-----	--	-----	--	--	--	--

Tel vorentoe of agtertoe in 3's.

e.

300	303					318		
-----	-----	--	--	--	--	-----	--	--

f.

227	224			215				
-----	-----	--	--	-----	--	--	--	--

g.

373	375	377						
-----	-----	-----	--	--	--	--	--	--

Tel vorentoe of agtertoe in 5'e.

h.

85			70			55		
----	--	--	----	--	--	----	--	--

i.

240			255					280
-----	--	--	-----	--	--	--	--	-----

j.

405		395			380			365	
-----	--	-----	--	--	-----	--	--	-----	--

Tel in 4's vanaf 144 - 212.

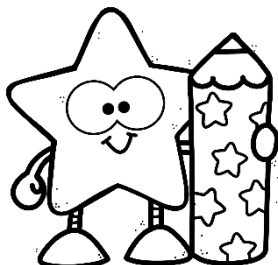

144			156					
	184				200			212

Kom ons dink slim!

Vul die ontbrekende getalle in.

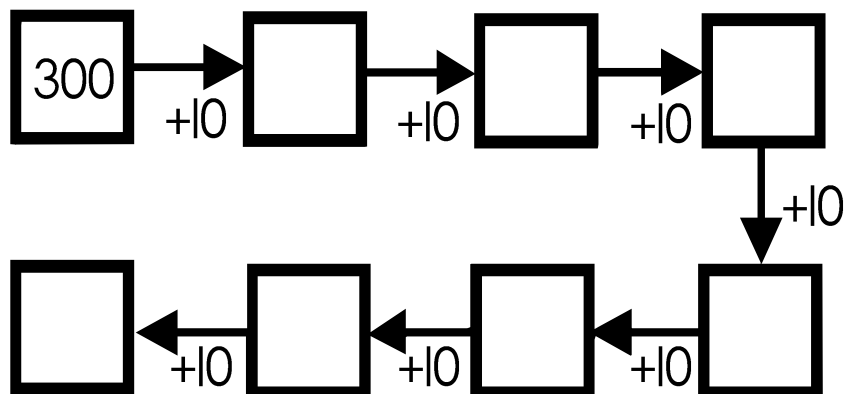
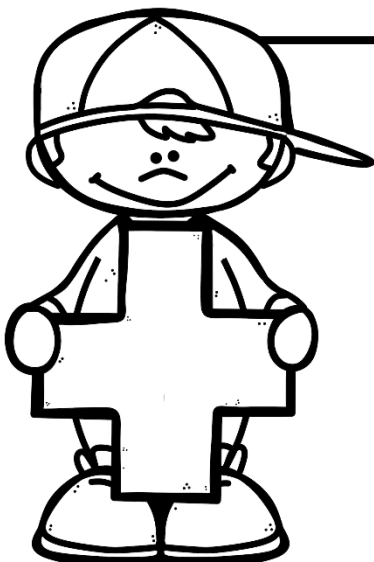
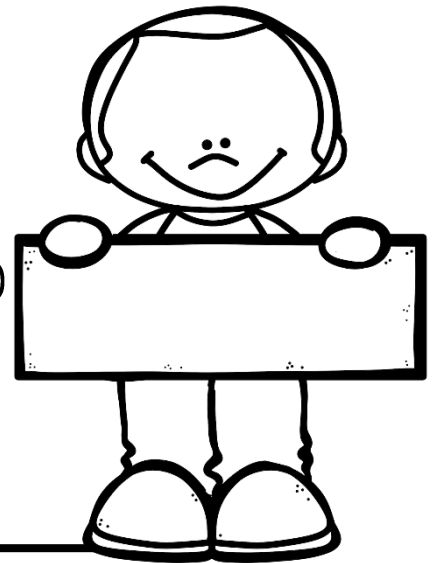
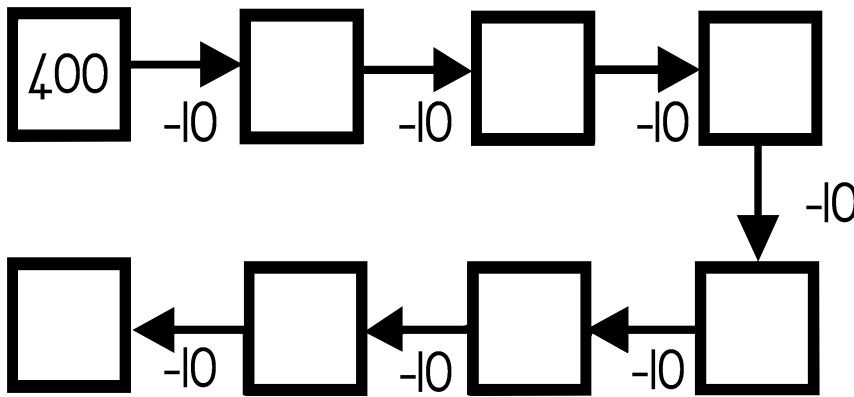
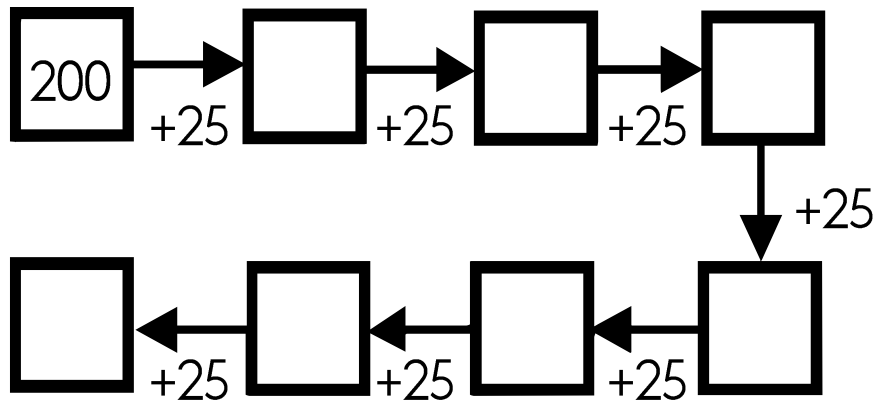
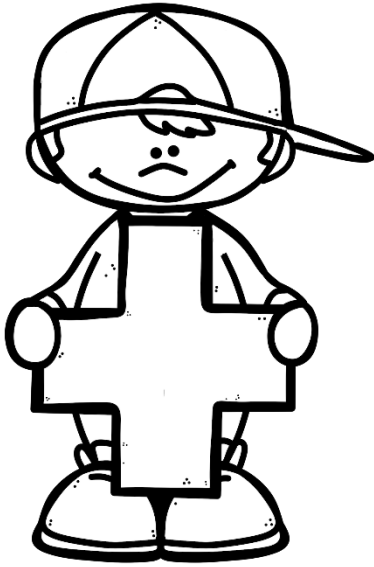

Kom ons dink slim!

Vul die ontbrekende getalle in.

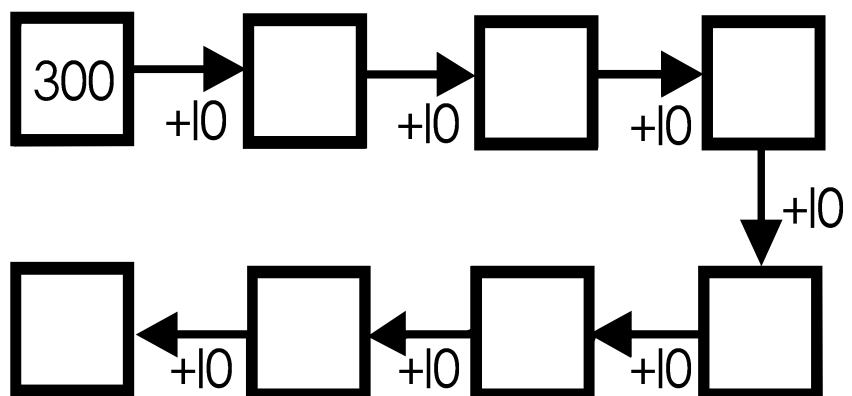
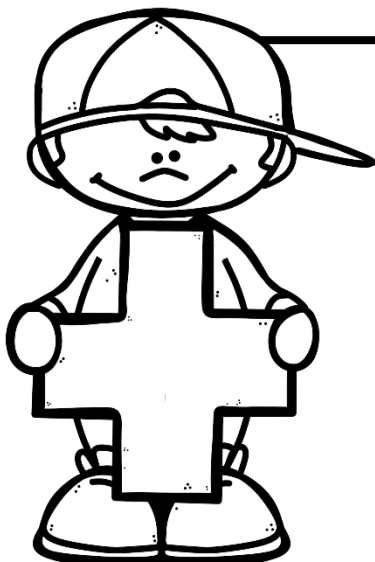
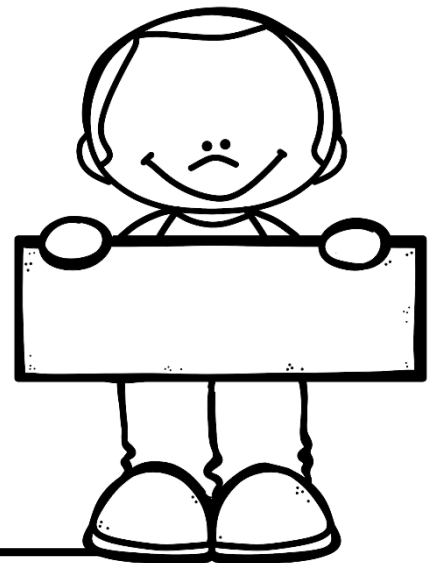
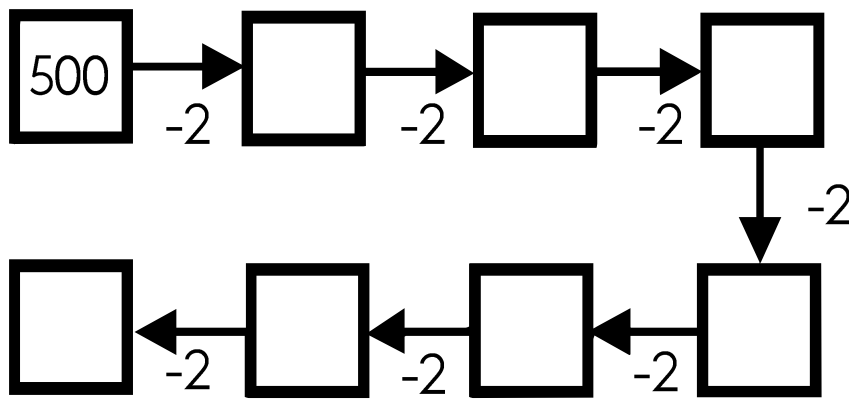
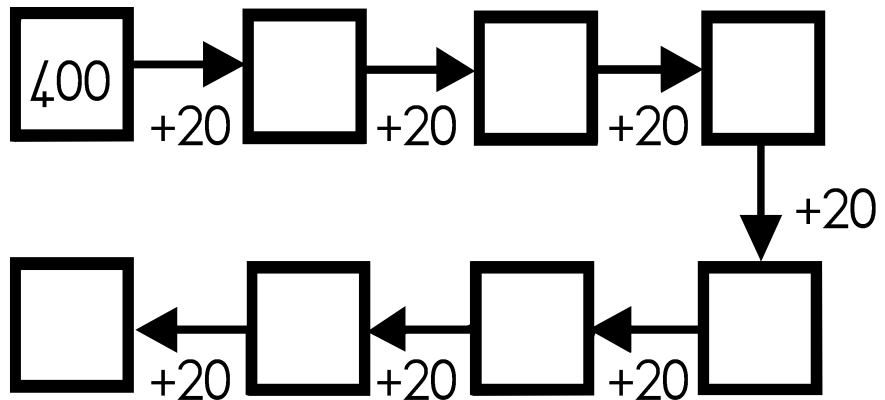
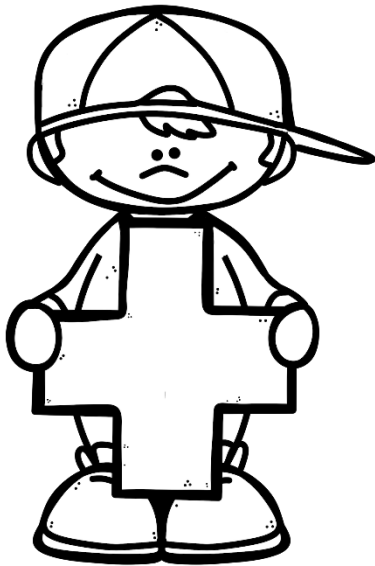

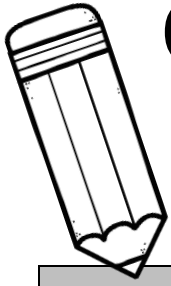

Getalname en getalsimbole



Pas kolom A by kolom B deur 'n lyn te trek met 'n liniaal.

Kolom A		Kolom B
99		tweehonderd en vyftig
489		driehonderd vier en twintig
161		eenhonderd drie en sestig
250		vierhonderd nege en tagtig
324		nege en negentig
163		drie en sewentig
73		eenhonderd een en sestig

Skryf die getalsimbole vir die volgende getalname.

Getalnaam	Getalsimbool
eenhonderd ses en sewentig	
tweehonderd en drie	
eenhonderd en vyftig	
tweehonderd drie en dertig	

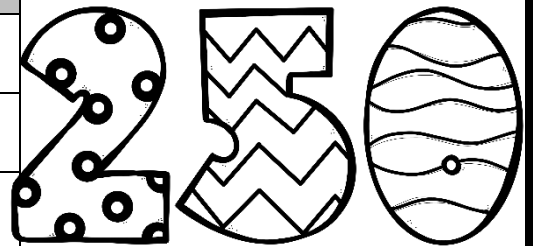

Skryf die getalnaam vir die volgende getalsimbole.

Getalsimbool	Getalnaam
129	
231	
250	
190	

Kleiner as, groter as en is gelyk aan

Vul in: Kleiner as, groter as of is gelyk aan.



kleiner as



groter as

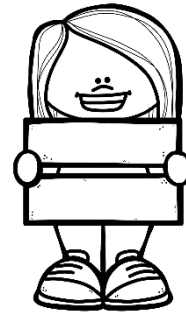

is gelyk aan

339		239
-----	--	-----

$3 + 3 + 3 + 3$		3×4
-----------------	--	--------------

339		239
-----	--	-----

$2H + 3T + 9E$		329
----------------	--	-----

119		199
-----	--	-----

88		44×2
----	--	---------------

2×5		5×2
--------------	--	--------------

$4 + 4 + 4 + 4$		4×6
-----------------	--	--------------

6×5		6×4
--------------	--	--------------

$1H + 2T + 7E$		127
----------------	--	-----

Vul in: meer as of minder as

- 129 is 5 _____ as 124.
- 235 is 3 _____ as 238.
- 170 is 10 _____ as 180.
- 175 is 25 _____ as 200.
- 140 is 20 _____ as 160.
- 200 is 50 _____ as 150.



Stygende en dalende orde

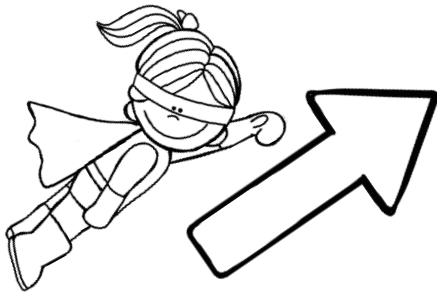

stygende orde

kleinste na die grootste

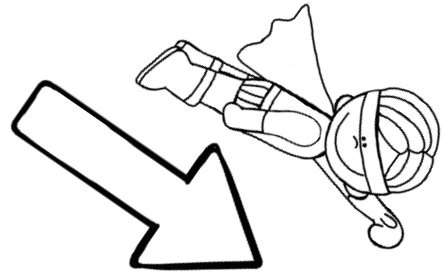

dalende orde

grootste na die kleinste

Rangskik die getalle in die dalende orde.

a. 339, 93, 313, 133, 393, 323, 191

_____ / _____ / _____ / _____ / _____ / _____ / _____

b. 41, 451, 145, 411, 51, 151, 455

_____ / _____ / _____ / _____ / _____ / _____ / _____

c. 212, 120, 12, 210, 121, 21, 222

_____ / _____ / _____ / _____ / _____ / _____ / _____

Rangskik die volgende in die stygende orde.

a. 71, 171, 17, 177, 170, 107, 117

_____ / _____ / _____ / _____ / _____ / _____ / _____

b. 354, 35, 54, 354, 350, 453, 341

_____ / _____ / _____ / _____ / _____ / _____ / _____

c. 283, 82, 238, 382, 28, 388, 383

_____ / _____ / _____ / _____ / _____ / _____ / _____



Plekwaarde en getalwaarde

Plekwaarde

Plekwaarde wys die plek van die syfer aan.

3	4	1
H	T	E

$341 - H$

$341 - T$

$341 - E$

Getalwaarde

Getalwaarde dui die waarde van die getal aan.

$341 - 300$

$341 - 40$

$341 - 1$

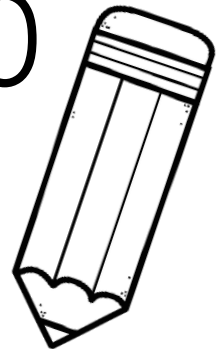

Skryf die plekwaarde van die volgende getalle.

1. $231 \rightarrow$ ____

2. $231 \rightarrow$ ____

3. $381 \rightarrow$ ____

4. $498 \rightarrow$ ____

5. $498 \rightarrow$ ____

6. $498 \rightarrow$ ____

7. $273 \rightarrow$ ____

8. $273 \rightarrow$ ____

9. $273 \rightarrow$ ____

10. $156 \rightarrow$ ____

Skryf die getalwaarde van die volgende getalle.

1. $231 \rightarrow$ ____

2. $231 \rightarrow$ ____

3. $381 \rightarrow$ ____

4. $498 \rightarrow$ ____

5. $498 \rightarrow$ ____

6. $498 \rightarrow$ ____

7. $273 \rightarrow$ ____

8. $273 \rightarrow$ ____

9. $273 \rightarrow$ ____

10. $156 \rightarrow$ ____

Ontbind twee-syfer getalle in veelvoude van honderde, tiene en ene. Die eerste een is vir jou gedoen.

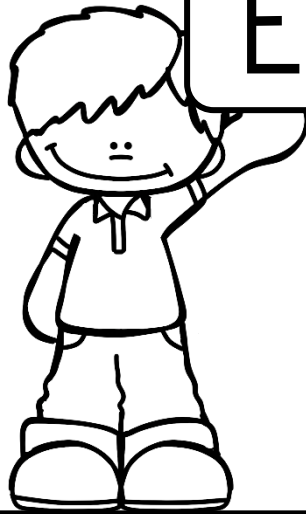
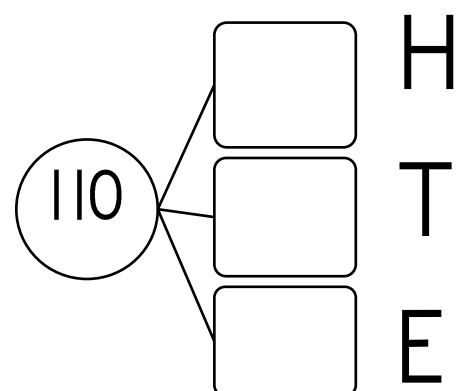
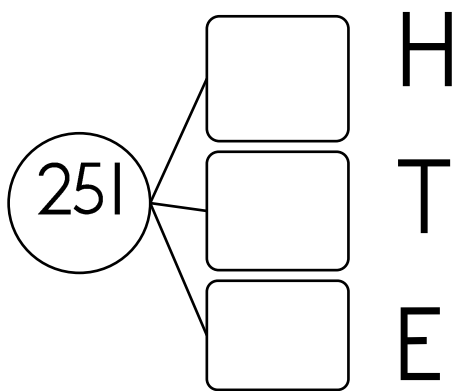
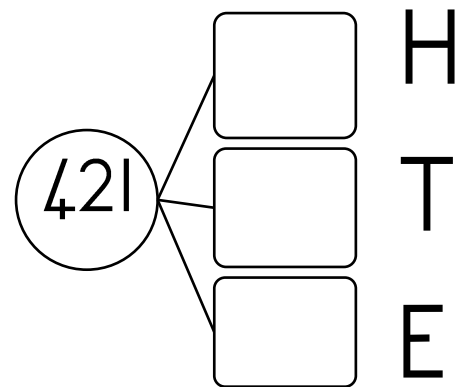
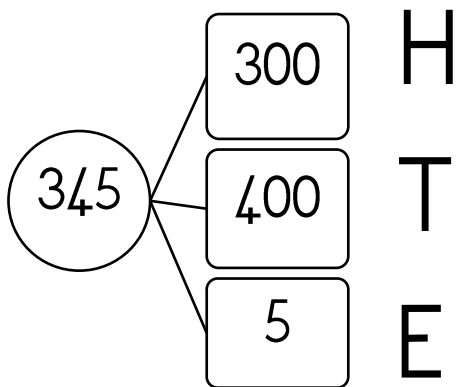

Ontbind 3 syfer getalle in veelvoude van honderde, tiene en ene.

Voltooi die ontbrekende getalle in die blokke.

Byvoorbeeld:
 $273 = 200 + 70 + 3$

1. $346 =$ _____
2. $428 =$ _____
3. $499 =$ _____
4. $102 =$ _____
5. $245 =$ _____
6. $392 =$ _____

1. $467 = 400 + \square + 6$
2. $300 + 60 + 8 = \square$
3. $125 = \square + 20 + 5$
4. $200 = 200 + \square + \square$
5. $400 + 20 + 8 = \square$
6. $398 = 300 + \square + \square$
7. $400 + 0 + 2 = \square$
8. $200 + 50 + 0 = \square$

Plekwaarde

Skryf die getalle:

Byvoorbeeld:

2 honderd + 6 tiene en 7 ene = 267

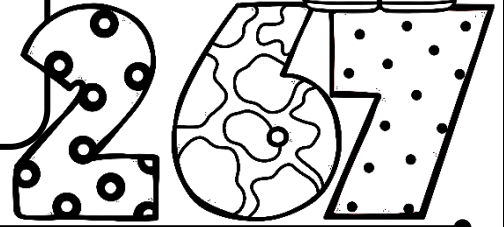

	Getal
1 honderd en 3 tiene	
2 honderd en 4 tiene en 5 ene	
3 honderd + 9 tiene + 2 ene	
4 honderd + 5 tiene + 7 ene	
2 honderd + 7 tiene + 3 ene	
4 honderd + 1 tiene + 6 ene	
1 honderd + 2 tiene + 1 ene	
1 honderd + 3 tiene + 4 ene	
2 honderd + 9 ene	
3 honderd + 7 tiene	
2 honderd + 7 tiene + 5 ene	
4 honderd + 5 tiene	

Probleemoplossing

- Optel en aftrek -

Lees die woordprobleme. Wys jou bewerkings.

Skryf 'n getalsin vir elkeen.

Jan lees 115 bladsye. Karla lees 126 bladsye. Hoeveel meer bladsye het Karla as Jan gelees?

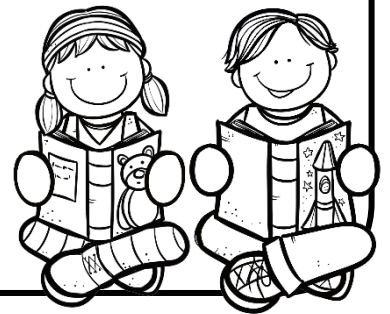

Ben het 218 albasters. Hy het 97 albasters minder as David. Hoeveel albasters het David?



Boer Ben tel sy diere. Hy tel 123 skape en 145 koeie. Hoeveel diere tel hy altesaam?

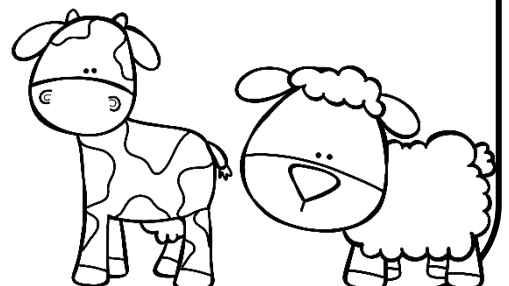

Probleemoplossing

- Optel en aftrek -

Lees die woordprobleme. Wys jou bewerkings.

Skryf 'n getalsin vir elkeen.

Mia pluk 34 appels en daarna nog 67 appels. Hoeveel appels het sy altesaam gepluk?

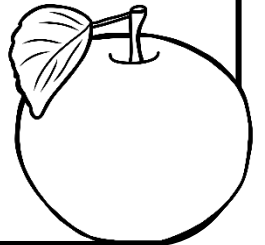

Zander tel 87 blokkies uit. Kobus tel 38 uit. Hulle stapel dit op 'n toring. Hoeveel meer blokkies tel Zander as Kobus?

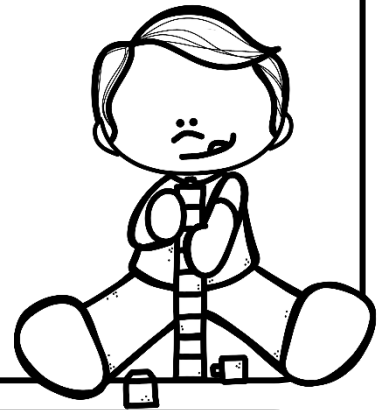

Benjamin verkoop spookasem. Hy begin met 92 stokkies spookasem en het nou 67 oor. Hoeveel spookasem het Benjamin tot dusver verkoop?



Probleemoplossing

- Herhaalde optel wat lei na vermenigvuldiging -

Lees die woordprobleme. Teken 'n prent indien nodig.
Skryf 'n getalsin vir elkeen.

'n Groentetuin het 12 rye pampoene. Elke ry het 7 pampoene.
Hoeveel pampoene is daar in die tuin?

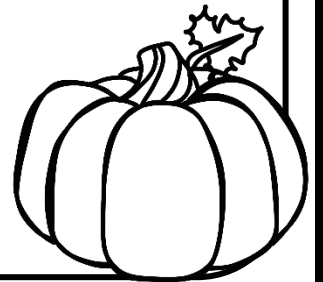

'n Groentetuin het 48 plante wat in rye geplant is. Daar is 7 plante
in elke ry. Hoeveel rye is daar?



Mia plant 10 rye saadjies. Daar is 7 saadjies in elke ry. Hoeveel
saadjies het sy altesaam geplant?

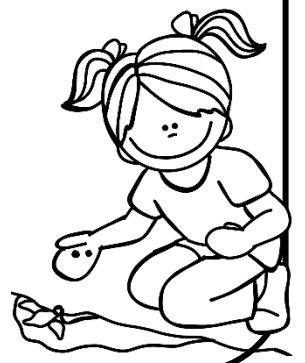

Probleemoplossing

- Herhaalde optelling wat lei na deling -

Lees die woordprobleme. Teken 'n prent indien nodig.
Skryf 'n getalsin vir elkeen.

Lisa het 9 pakkies. Sy pak 3 koekies in elke pakkie. Hoeveel koekies is daar altesaam

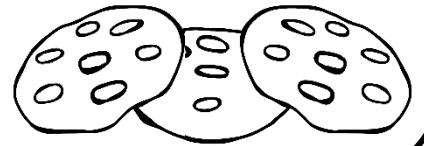

Ben het 20 suigstokkies. Hy wil dit graag gelykop verdeel sodat al 4 sy maats ewe veel kry. Hoeveel suigstokkies sal elke maat kry?

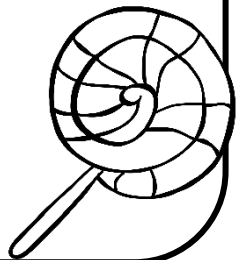

Karel het 66 lekkers. Elke dag eet hy 3 lekkers. Hoeveel dae kan hy lekkers eet?

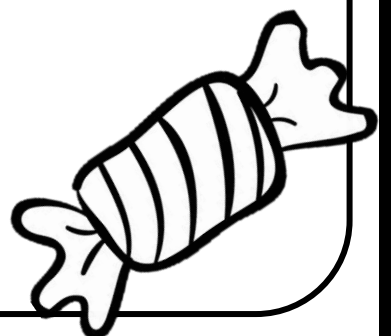

Geld

Stappe om 'n getal as rand en sent te skryf.

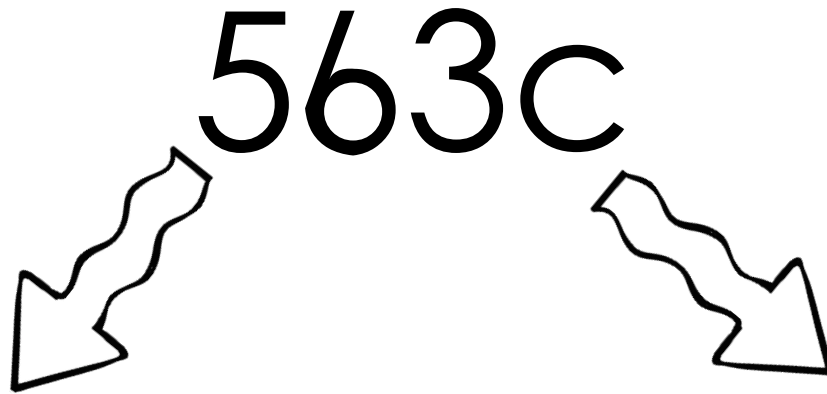

Die eerste getal kom voor die komma en dit is "rand".

Die laaste 2 getalle kom na die komma en dit is "sent".

$$= R5,63$$

Skryf die volgende as rand en sent.

	rand en sent
345c	
187c	
945c	
220c	
130c	
194c	
274c	

Tel die geld bymekaar. Skryf die antwoord eers in sent en dan in rand en sent.

	sent	rand en sent
$90c + 45c$		
$65c + 55c$		
$330c + 82c$		
$115c + 75c$		
$40c + 64c$		

Tel die geld bymekaar en skryf dit dan in rand en sent.

	Kolom vir bewerkings (indien nodig)	Rand en sent
$R1 + 50c + 15c + R6 =$		
$10c + 10c + 10c + 50c + 5c + 5c =$		
$R10 + 30c + 80c + R100 =$		
$R20 + R10 + R5 + 22c$		
$5c + 5c + 5c + R5 + R5 + R5 + R50$		

Breuke

1 hele



halwes – $\frac{1}{2}$

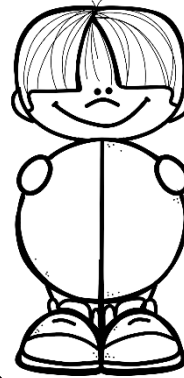

Die voorwerp of
vorm word in
twee ewe groot
dele gedeel.

derdes – $\frac{1}{3}$

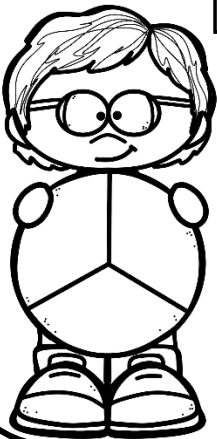

Die voorwerp of
vorm word in
drie ewe groot
dele gedeel.

kwarte – $\frac{1}{4}$

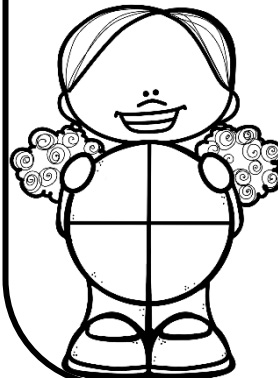

Die voorwerp of
vorm word in
vier ewe groot
dele gedeel.

vyfdes – $\frac{1}{5}$

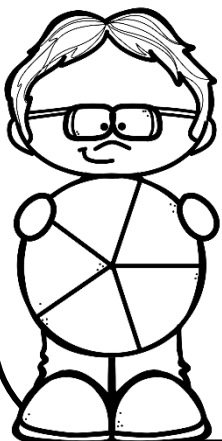

Die voorwerp of
vorm word in
vyf ewe groot
dele gedeel.

sesdes – $\frac{1}{6}$



Die voorwerp of
vorm word in
ses ewe groot
dele gedeel.

Breuke

Kleur die $\frac{1}{2}$ van die vorm in.

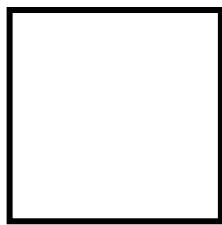
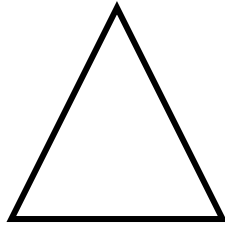
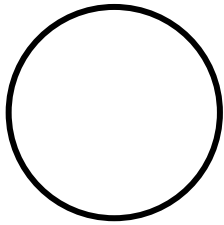

Kleur 'n $\frac{1}{4}$ van die vorm in.

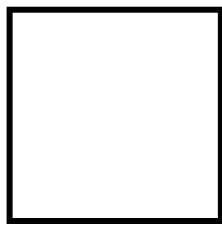
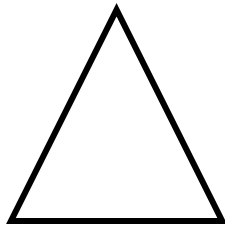
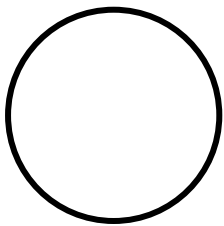

Kleur 'n $\frac{2}{4}$ van die vorm in.

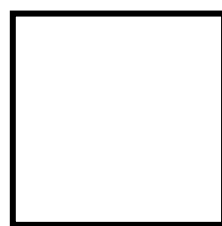
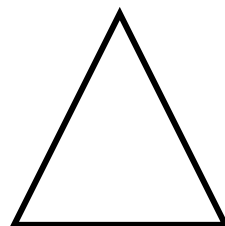
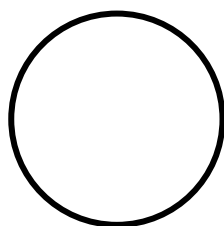

Kleur 'n $\frac{3}{4}$ van die vorm in.

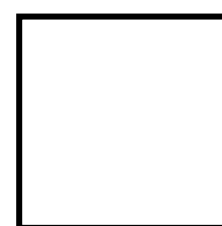
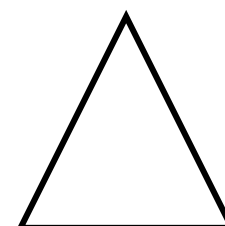
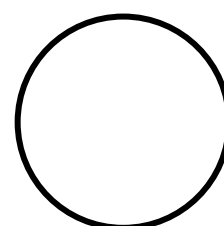

Kleur die volgende breukdele in.

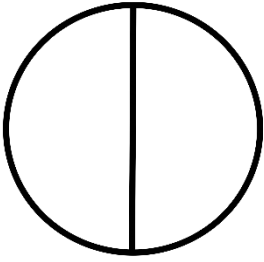

'n halwe

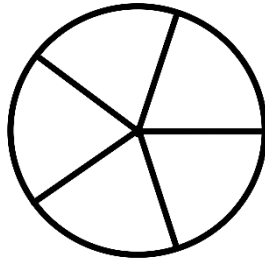

twee vyfdes

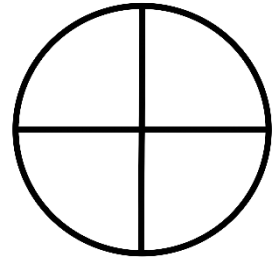

'n kwart

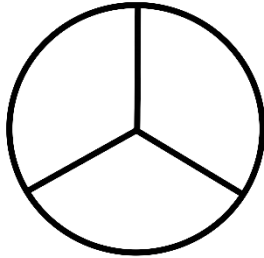

twee derdes

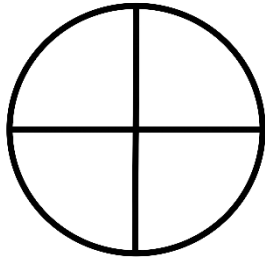

driekwart

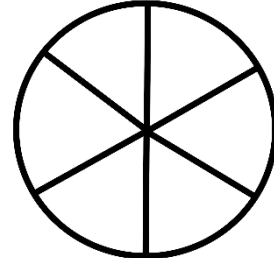

vier sesdes

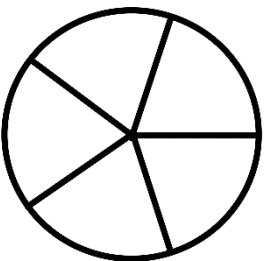

'n vyfde

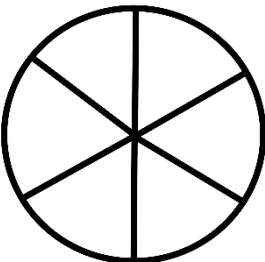

'n sesde

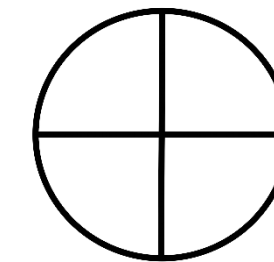

twee kwarte

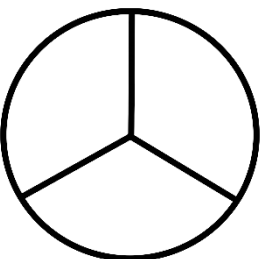

'n derde

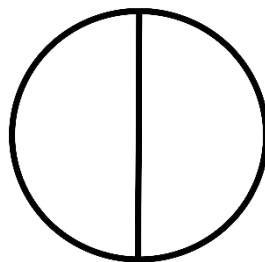

'n hele

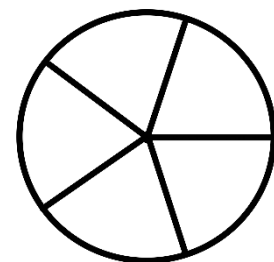

vier vyfdes

Watter breukdeel is ingekleur? Skryf die antwoord in breukvorm en in woorde. Die eerste een is vir jou gedoen.

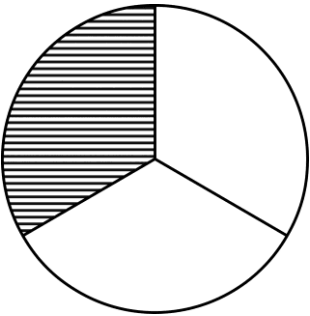

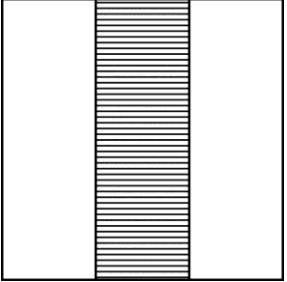
een derde
$\frac{1}{3}$

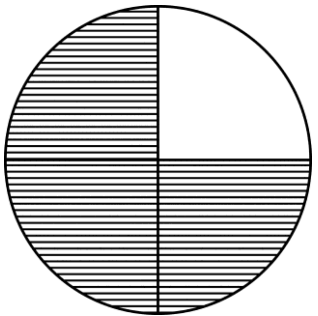

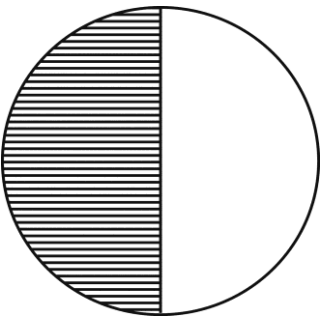

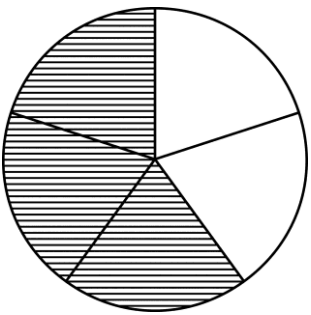

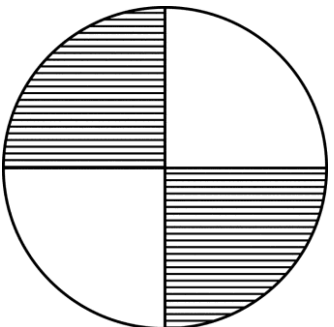



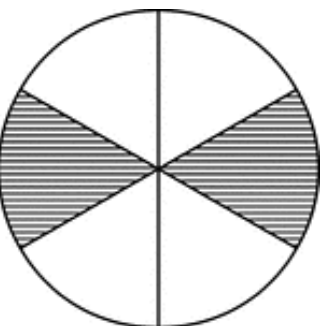

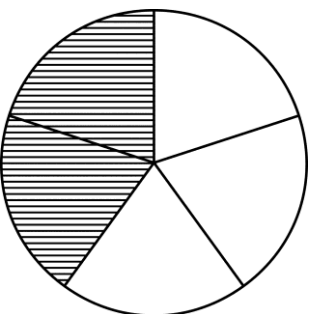

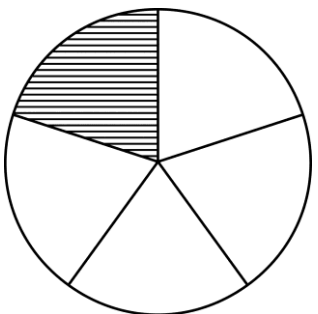

Kleiner as, groter as en is gelyk aan

Vul in: Kleiner as, groter as of is gelyk aan.



kleiner as



groter as

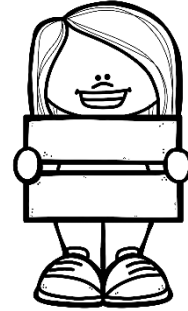

is gelyk aan

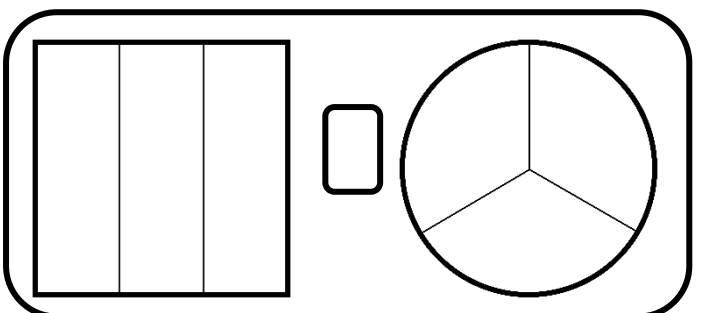
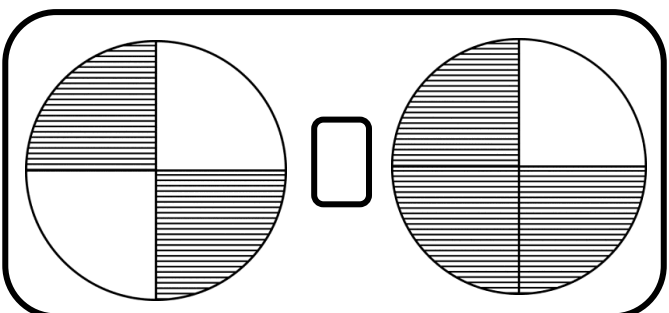
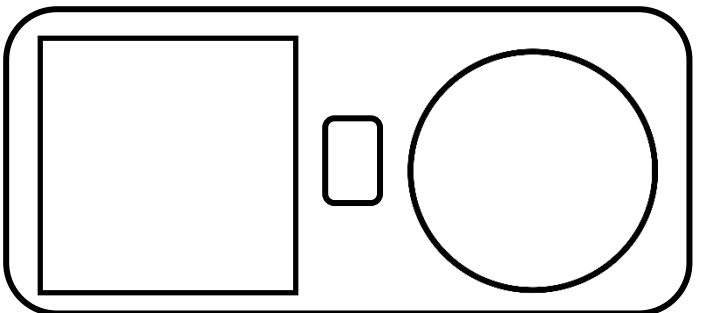
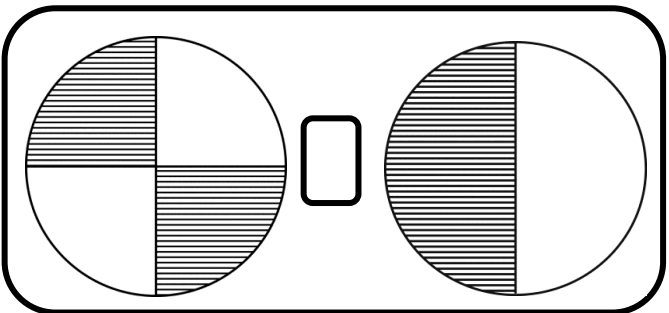
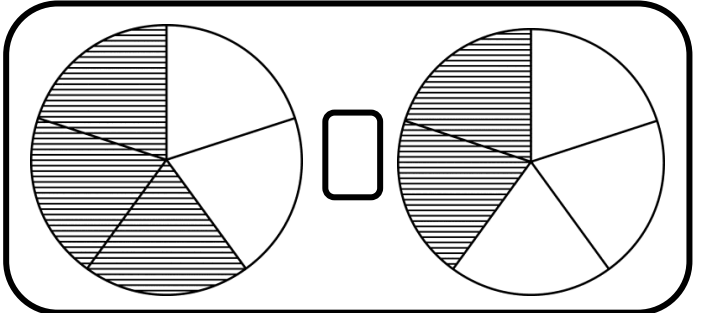
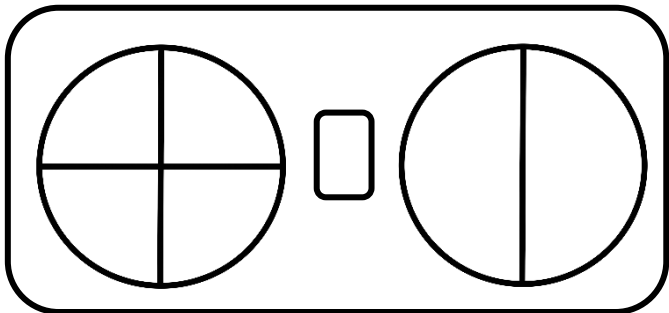
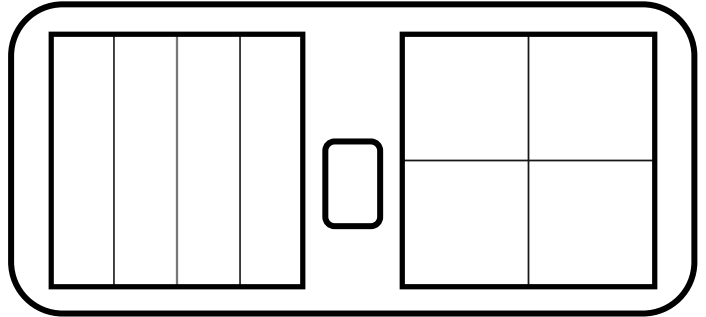
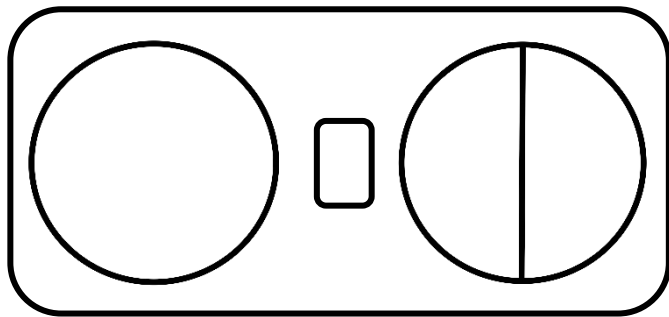

Breukestroke

Kleur die breukestroke op die volgende maniere in:

geel	1 hele					
rooi	$\frac{1}{2}$			$\frac{1}{2}$		
groen	$\frac{1}{3}$		$\frac{1}{3}$		$\frac{1}{3}$	
oranje	$\frac{1}{4}$	$\frac{1}{4}$		$\frac{1}{4}$	$\frac{1}{4}$	
blou	$\frac{1}{5}$	$\frac{1}{5}$		$\frac{1}{5}$	$\frac{1}{5}$	
pers	$\frac{1}{6}$	$\frac{1}{6}$	$\frac{1}{6}$	$\frac{1}{6}$	$\frac{1}{6}$	$\frac{1}{6}$

Vul in kleiner as of groter as.

$$\frac{1}{2} \square \frac{1}{4}$$

$$\frac{1}{3} \square \frac{1}{2}$$

$$\frac{1}{5} \square \frac{1}{6}$$

$$\frac{1}{6} \square \frac{1}{3}$$

$$\frac{3}{6} \square \frac{2}{5}$$

$$\frac{1}{6} \square \frac{1}{4}$$

Beantwoord die vrae deur na die breukestroke te kyk.

1. Hoeveel halwes is gelyk aan 'n hele? _____
2. Hoeveel kwarte is gelyk aan 'n hele? _____
3. Hoeveel kwarte is daar in een halwe? _____
4. Hoeveel derdes is gelyk aan 'n hele? _____
5. Hoeveel sesdes is gelyk aan 'n derde? _____
6. Hoeveel sesdes is gelyk aan 'n halwe? _____

Optelling

Voorbeeld

Metode 1

Optel van drie-syfer getalle met twee-syfer getalle

$$324 + 82 =$$

$$324 + 82 = (300 + 20 + 4) + (80 + 2)$$

$$= 300 + (20 + 80) + (4 + 2)$$

$$= (300 + 100) + 6$$

$$= 400 + 6$$

$$= 406$$

Metode 2

Optel van twee drie-syfer getalle

$$323 + 136 =$$

$$323 + 136 = (300 + 20 + 3) + (100 + 30 + 6)$$

$$= (300 + 100) + (20 + 30) + (3 + 6)$$

$$= 400 + 50 + 9$$

$$= 459$$

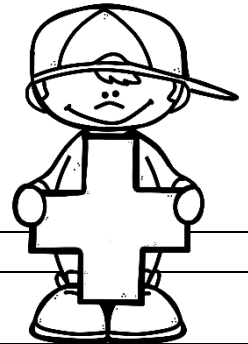

Gebruik die metodes hierbo om die somme te bereken.

$$278 + 36 =$$

$$245 + 231 =$$

$$265 + 148 =$$

$$114 + 62 =$$

$$132 + 123 =$$

$$276 + 48 =$$

Af trekking

Voorbeeld

Metode 1

Af trekking deur die ontbinding van beide getalle

$$889 - 137 =$$

$$889 - 137 = (800 + 80 + 9) - (100 + 30 + 7)$$

$$= (800 - 100) + (80 - 30) + (9 - 7)$$

$$= 700 + 50 + 2$$

$$= 752$$

Metode 2

Af trekking deur die ontbinding van een getal

$$889 - 137 =$$

$$889 - (100 + 30 + 7)$$

$$\rightarrow 889 - 100$$

$$\rightarrow 789 - 30$$

$$\rightarrow 759 - 7$$

$$= 752$$

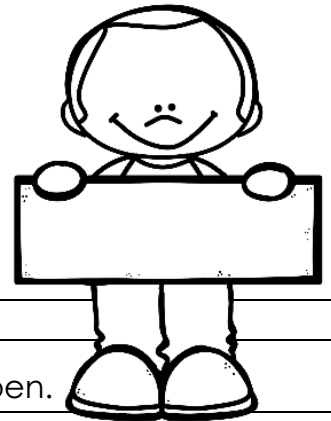

Gebruik enige van die metodes hierbo om die somme te doen.

$$158 - 146 =$$

$$194 - 122 =$$

$$288 - 199 =$$

$$162 - 114 =$$

$$132 - 123 =$$

$$276 - 148 =$$

Vermenigvuldiging

Voltooi die tabelle deur te vermenigvuldig.

	2	3	4	5	6	7	8	9	10
x2									
x3									
x4									
x5									
x10									

Voltooi die somme.

$12 = 2 \times \square$

$24 = 3 \times \square$

$\square \times 3 = 12$

$9 = \square \times 3$

$3 \times \square = 12$

$6 = 3 \times \square$

$2 \times \square = 4$

$2 \times \square = 10$

$\square \times 3 = 3$

$\square \times 5 = 15$

$4 \times \square = 8$

$\square \times 5 = 25$

$4 \times \square = 16$

$3 \times \square = 12$

$\square \times 5 = 50$

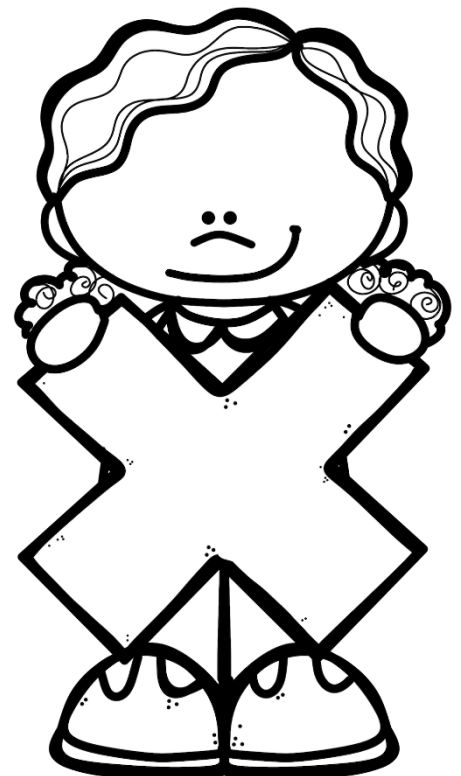

Halveer

Halveer die volgende getalle.

2 =	10 =	22 =	40 =	24 =
4 =	8 =	20 =	50 =	26 =
16 =	12 =	30 =	14 =	200 =

Halveer die getalle deur die diagramme te voltooi.

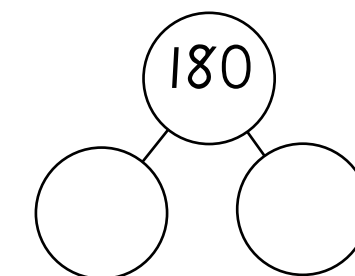
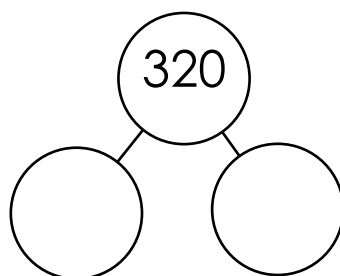
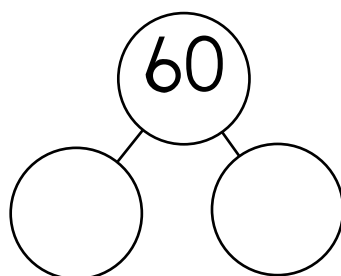
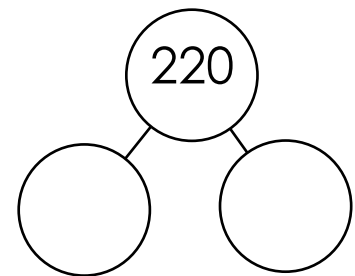
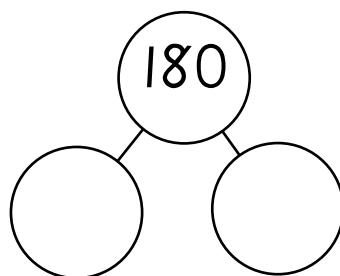
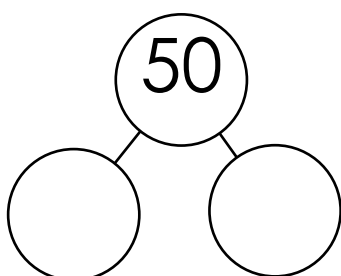
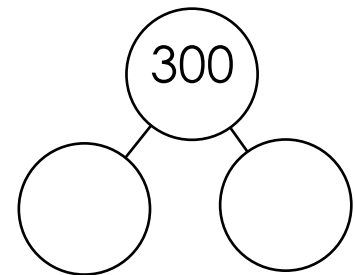
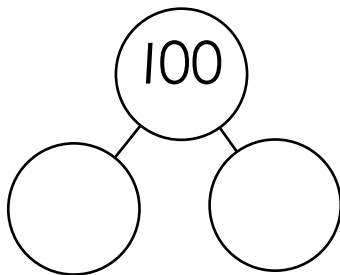
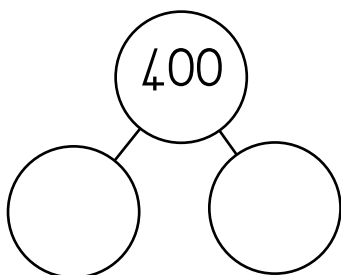
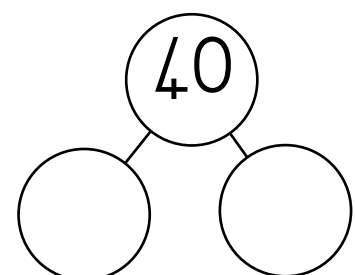
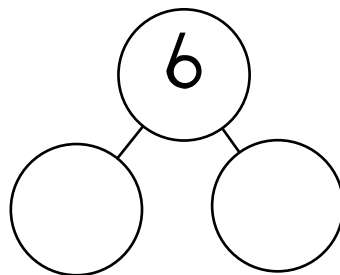
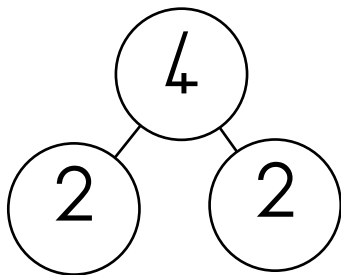

Verdubbel

Verdubbel die volgende getalle.

2 =	10 =	22 =	40 =	24 =
4 =	8 =	20 =	50 =	120 =
150 =	12 =	30 =	14 =	200 =
170 =	60 =	6 =	13 =	15 =

Probleemoplossing met verdubbel en halveer.

Karla wil graag vir haar 'n rok koop. Sy het nog net die helfte van die bedrag gespaar. Hoeveel moet sy nog spaar?

R185



Mia se rok se prys is dubbel die prys van die een. Hoeveel kos Mia se rok?

R79

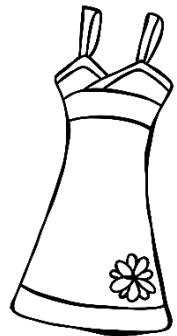

Voltooi die vloeiagramme.

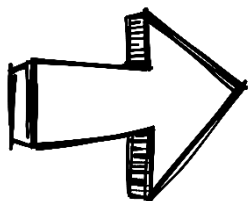
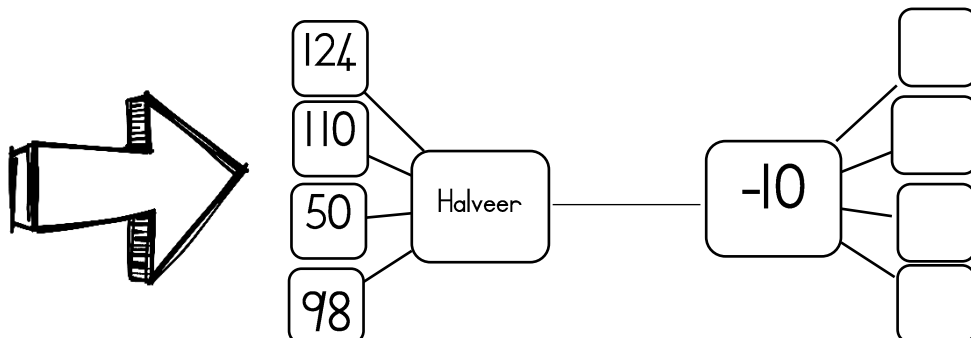
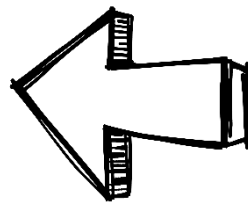
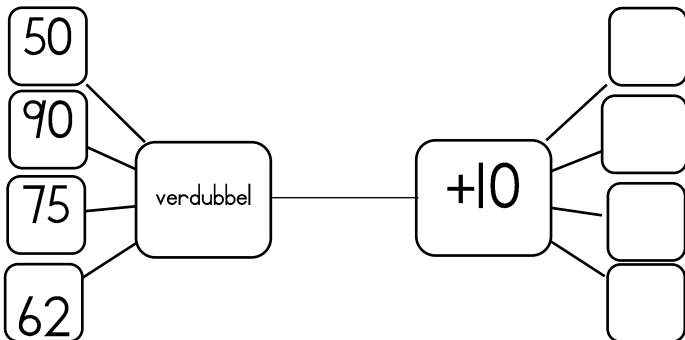

3D-voorwerpe

Kleur die regte antwoorde in.

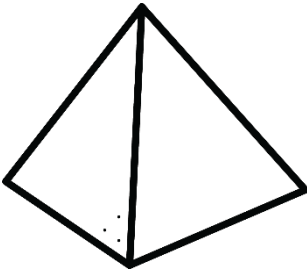
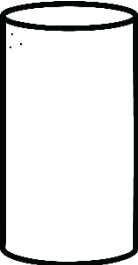
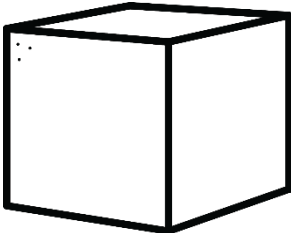
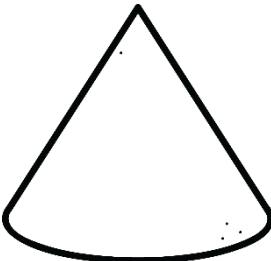
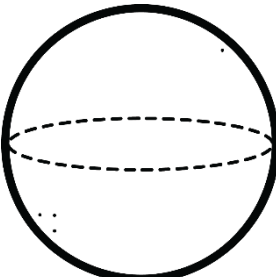
	Naam van 3D-voorwerp	Tipe oppervlak	2D-vorms wat die vlakke van die 3D-voorwerp voorstel
	<input type="checkbox"/> silinder <input type="checkbox"/> kubus (boks) <input type="checkbox"/> sfeer (bal) <input type="checkbox"/> keël <input type="checkbox"/> piramiede	<input type="checkbox"/> plat <input type="checkbox"/> geboë	<input type="checkbox"/> vierkant <input type="checkbox"/> sirkel <input type="checkbox"/> driehoek <input type="checkbox"/> reghoek
	<input type="checkbox"/> silinder <input type="checkbox"/> kubus (boks) <input type="checkbox"/> sfeer (bal) <input type="checkbox"/> keël <input type="checkbox"/> piramiede	<input type="checkbox"/> plat <input type="checkbox"/> geboë	<input type="checkbox"/> vierkant <input type="checkbox"/> sirkel <input type="checkbox"/> driehoek <input type="checkbox"/> reghoek
	<input type="checkbox"/> silinder <input type="checkbox"/> kubus (boks) <input type="checkbox"/> sfeer (bal) <input type="checkbox"/> keël <input type="checkbox"/> piramiede	<input type="checkbox"/> plat <input type="checkbox"/> geboë	<input type="checkbox"/> vierkant <input type="checkbox"/> sirkel <input type="checkbox"/> driehoek <input type="checkbox"/> reghoek
	<input type="checkbox"/> silinder <input type="checkbox"/> kubus (boks) <input type="checkbox"/> sfeer (bal) <input type="checkbox"/> keël <input type="checkbox"/> piramiede	<input type="checkbox"/> plat <input type="checkbox"/> geboë	<input type="checkbox"/> vierkant <input type="checkbox"/> sirkel <input type="checkbox"/> driehoek <input type="checkbox"/> reghoek
	<input type="checkbox"/> silinder <input type="checkbox"/> kubus (boks) <input type="checkbox"/> sfeer (bal) <input type="checkbox"/> keël <input type="checkbox"/> piramiede	<input type="checkbox"/> plat <input type="checkbox"/> geboë	<input type="checkbox"/> vierkant <input type="checkbox"/> sirkel <input type="checkbox"/> driehoek <input type="checkbox"/> reghoek

3D-voorwerpe

Kleur die 3D-voorwerpe op die volgende maniere in.

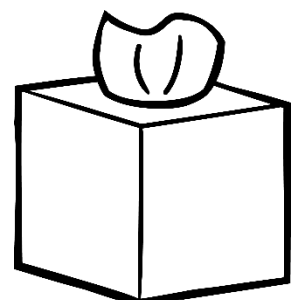
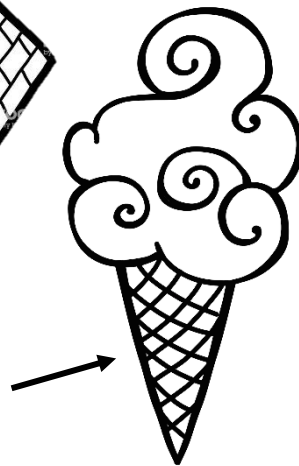
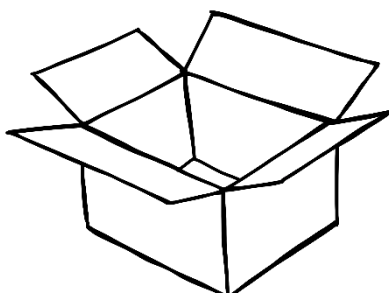
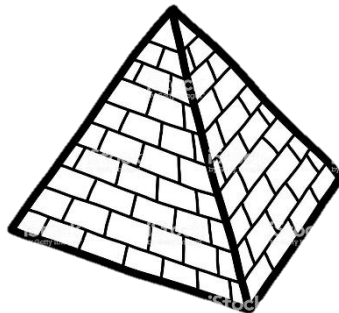
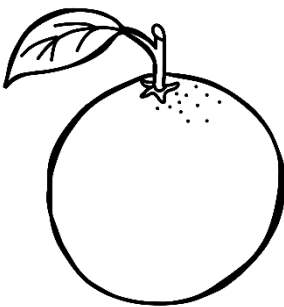
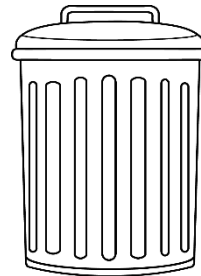
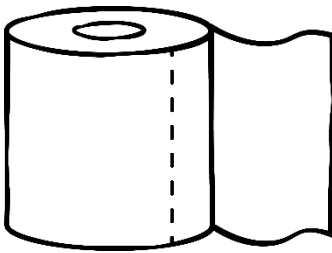
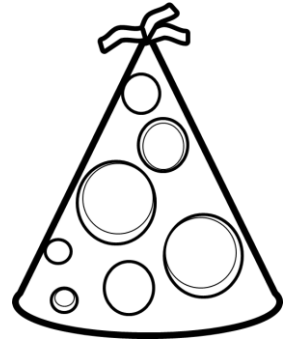
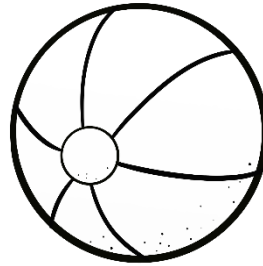
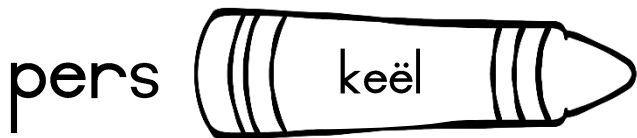
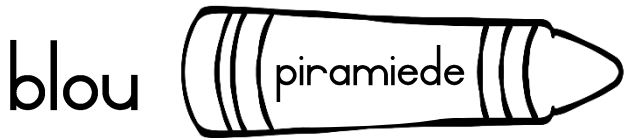
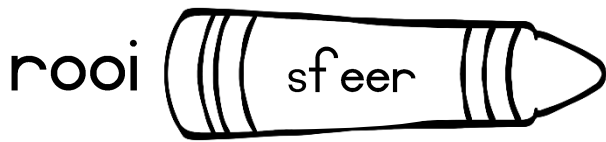

Aansigte

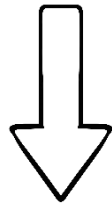

bokant

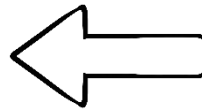
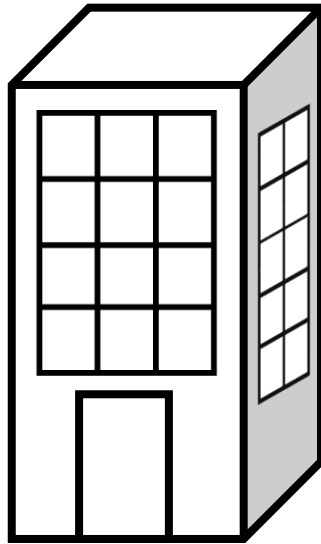

sykant

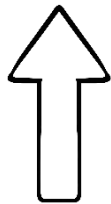

voorkant

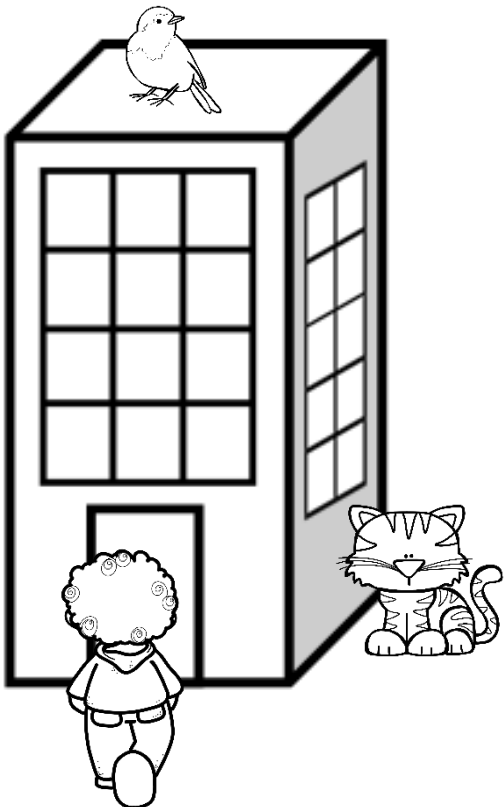

Beantwoord die vrae deur een van die volgende aansigte in te vul:

voorkant, bokant, sykant

1. Waar is die voël? _____
2. Waar staan die seun? _____
3. Waar sit die kat? _____

Simmetrie

'n Simmetrielyn verdeel 'n vorm in twee halwes sodat elke halwe 'n speelbeeld van die ander is.

'n Vorm is simmetries indien jy dit met die simmetrielyn langs kan vou en die twee helftes presies dieselfde is.

Teken 'n simmetrielyn vir die volgende vorms en prente.

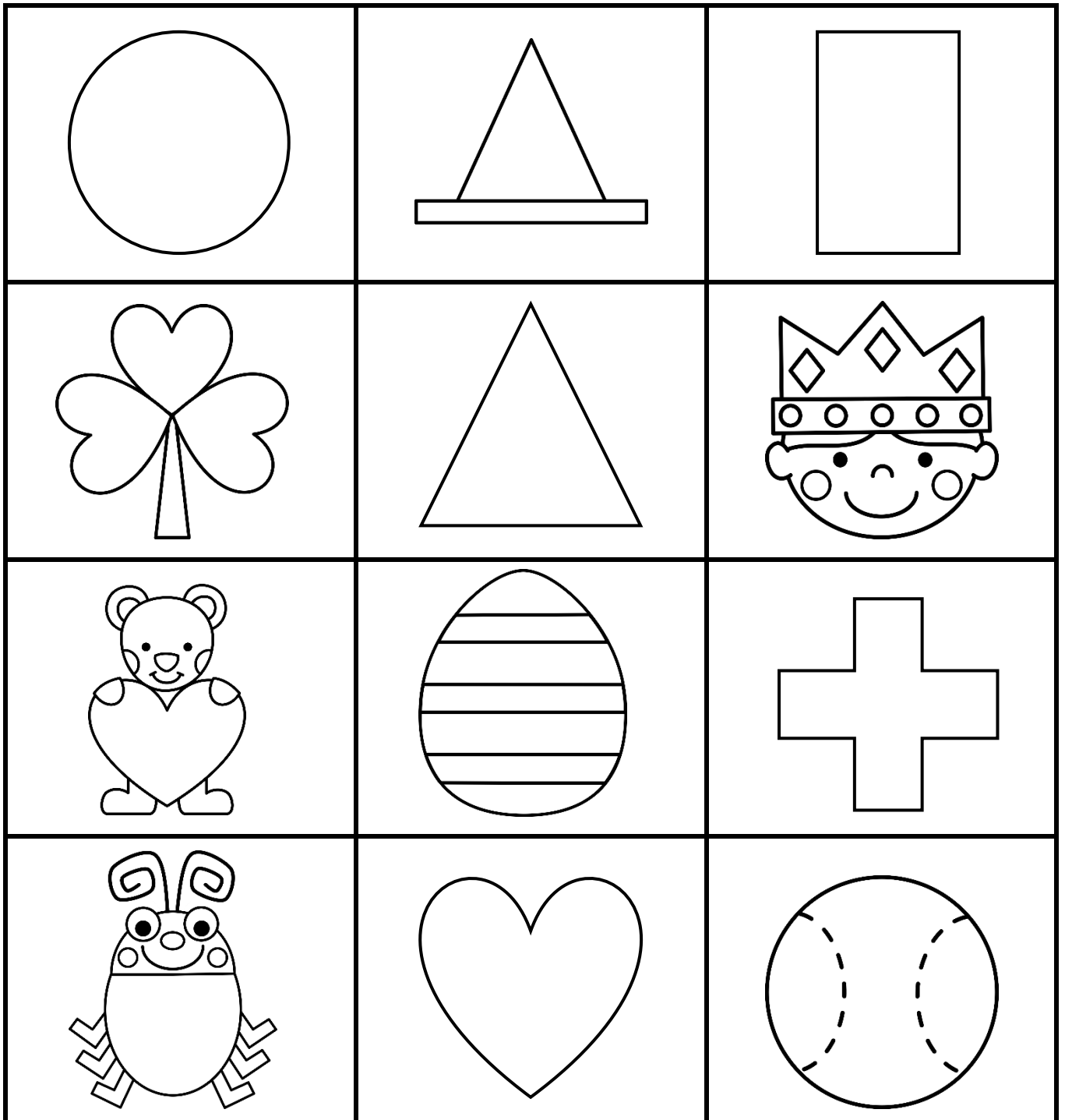

Simmetrie

- Knip die prente op die volgende bladsy uit.
- Vou dan die prent presies in die helfte sodat albei kante dieselfde lyk.
- Trek 'n stippellyn met 'n kleurpotlood en liniaal op die lyn waar die prent gevou is.
- Plak dan die prente in die blokke hieronder.

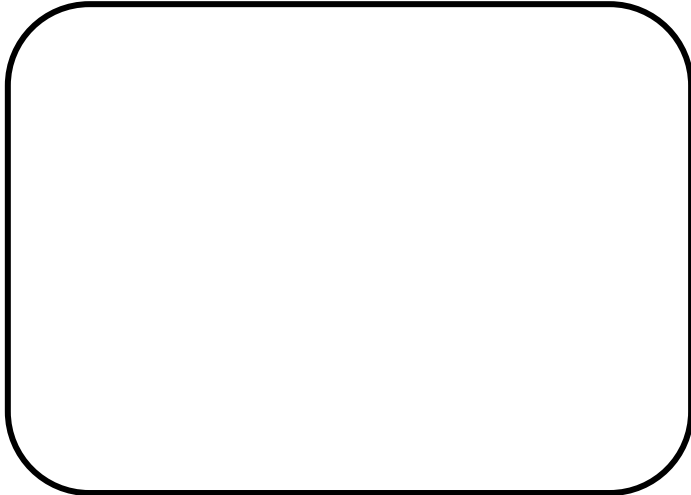

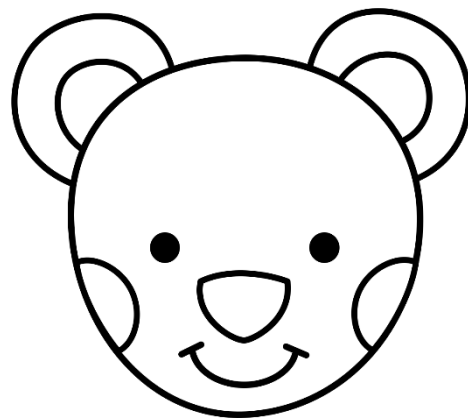
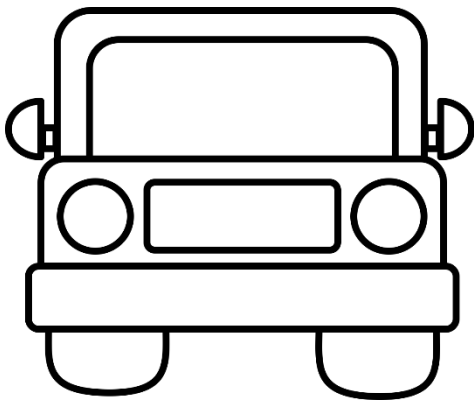
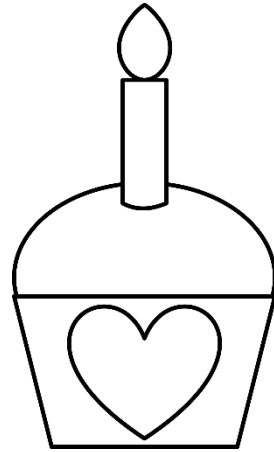
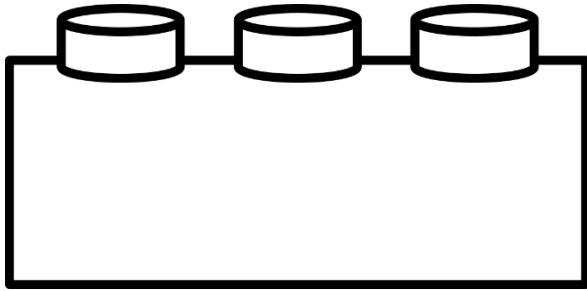
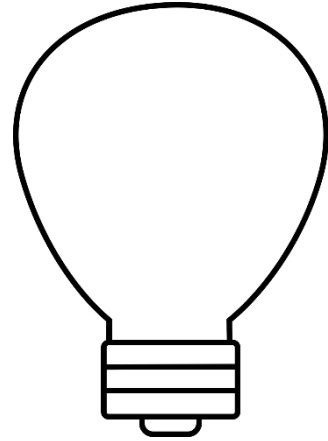
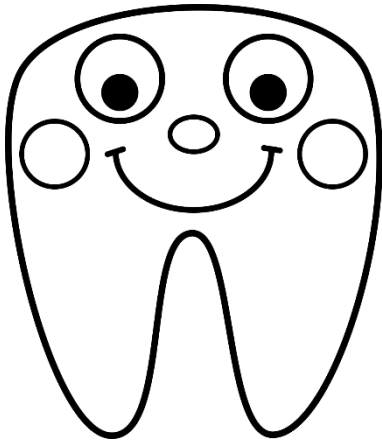

Meetkundige patrone

Brei die patrone uit en beskryf die patroon in woorde.



Beskryf die patroon.



Beskryf die patroon.



Beskryf die patroon.



Beskryf die patroon.

Getalpatrone

Voltooi die volgende patrone.

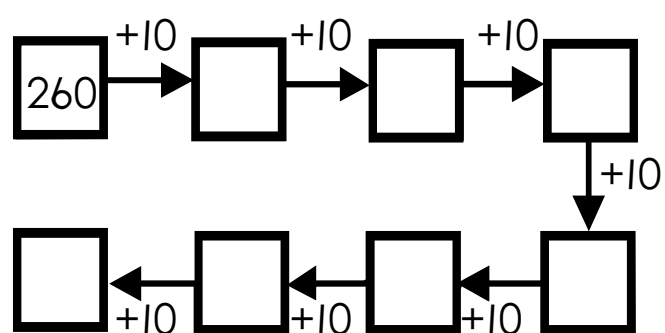
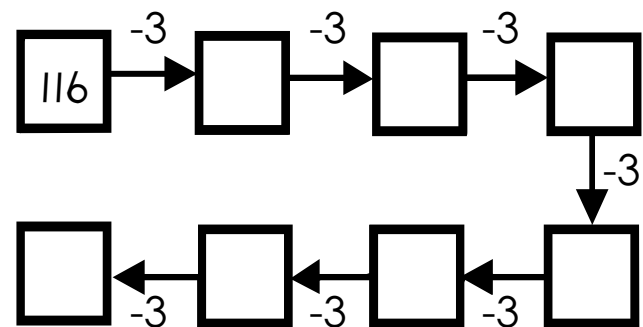
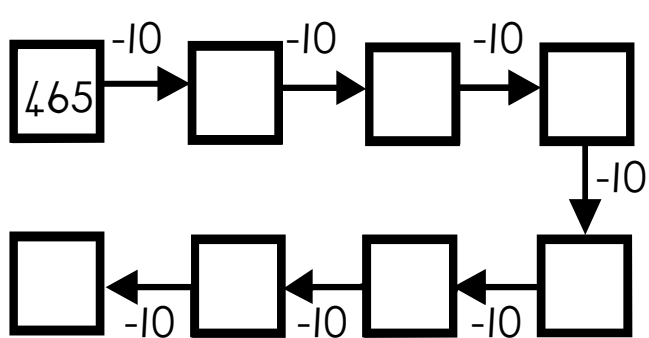
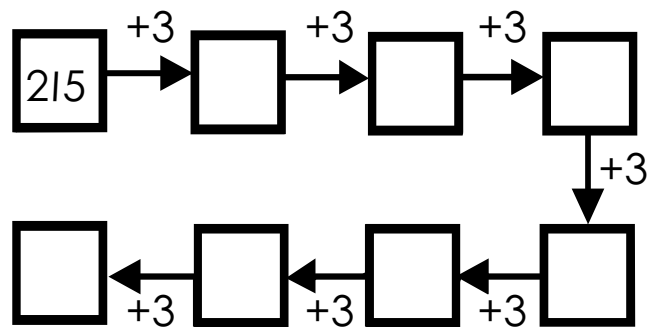
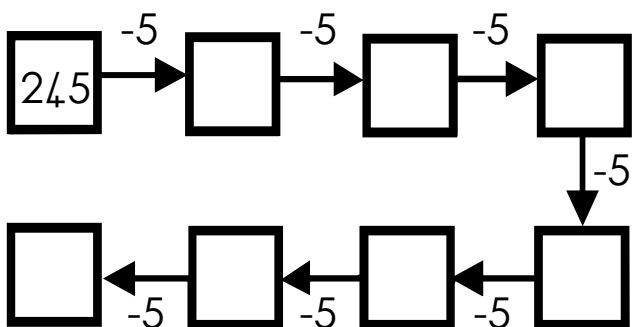
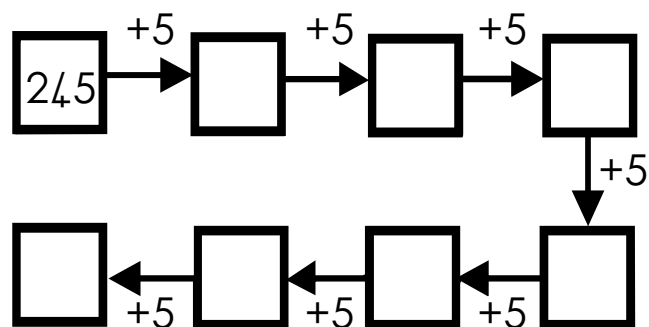
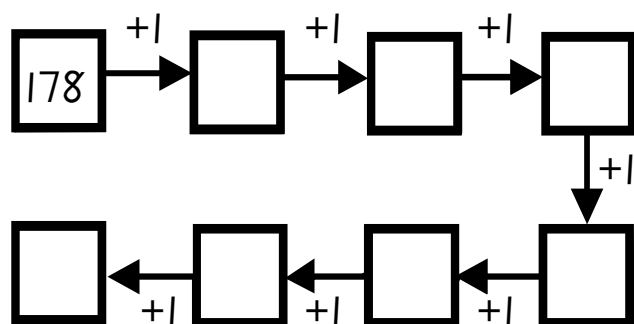
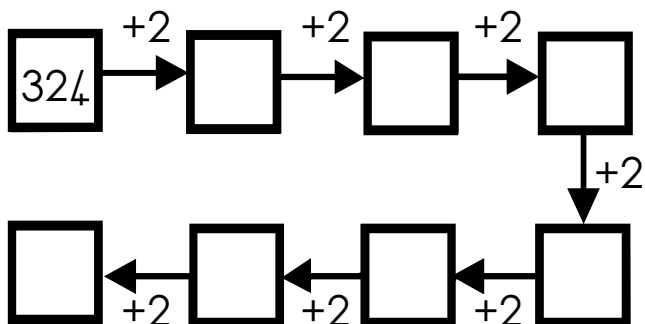

← Tyd →

ure

Wanneer die lang wyser op die 12 is, dan is dit ure.

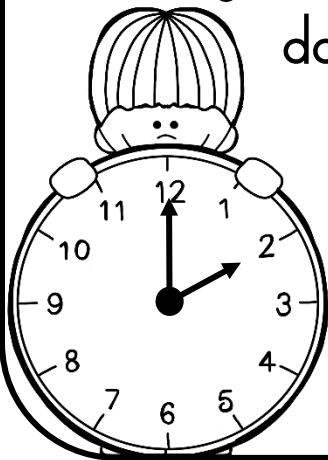

halfure

Wanneer die lang wyser op die 6 is, dan is dit halfure.



kwart oor

Wanneer die lang wyser op die 3 is, dan is dit kwart oor.

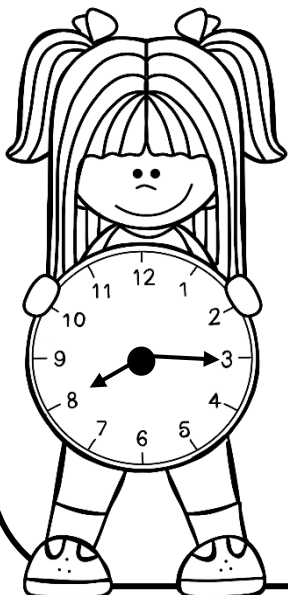

kwart voor

Wanneer die lang wyser op die 9 is, dan is dit kwart voor.

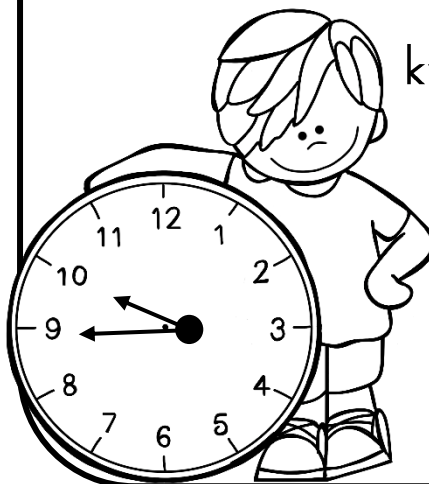

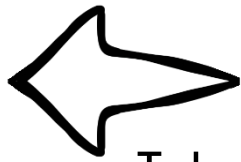

Analoog

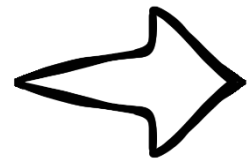

Teken die wysers vir elke horlosie.

half twee	drie uur	kwart oor twee	kwart voor nege
ses uur	half vier	vier uur	kwart oor vyf
half sewe	kwart voor drie	half elf	kwart oor sewe
kwart voor vier	Half agt	kwart oor twaalf	agt uur

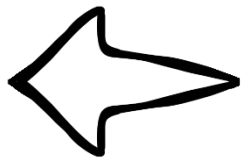

Analoog

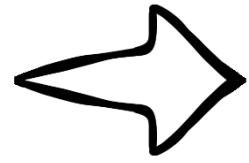

Skryf die tyd neer vir elke horlosie.

uur

1 uur = 60 minute

:60

:05

:55

:50

:10

kwart
voor

:45

kwart
oor

:15

kwartier =
15 minute

:40

:20

Die tyd op die horlosie in digitale tyd is:

3:15 vm. (voor middag)

15:15 nm. (na middag)

:35

:30

:25

half

half uur = 30 minute

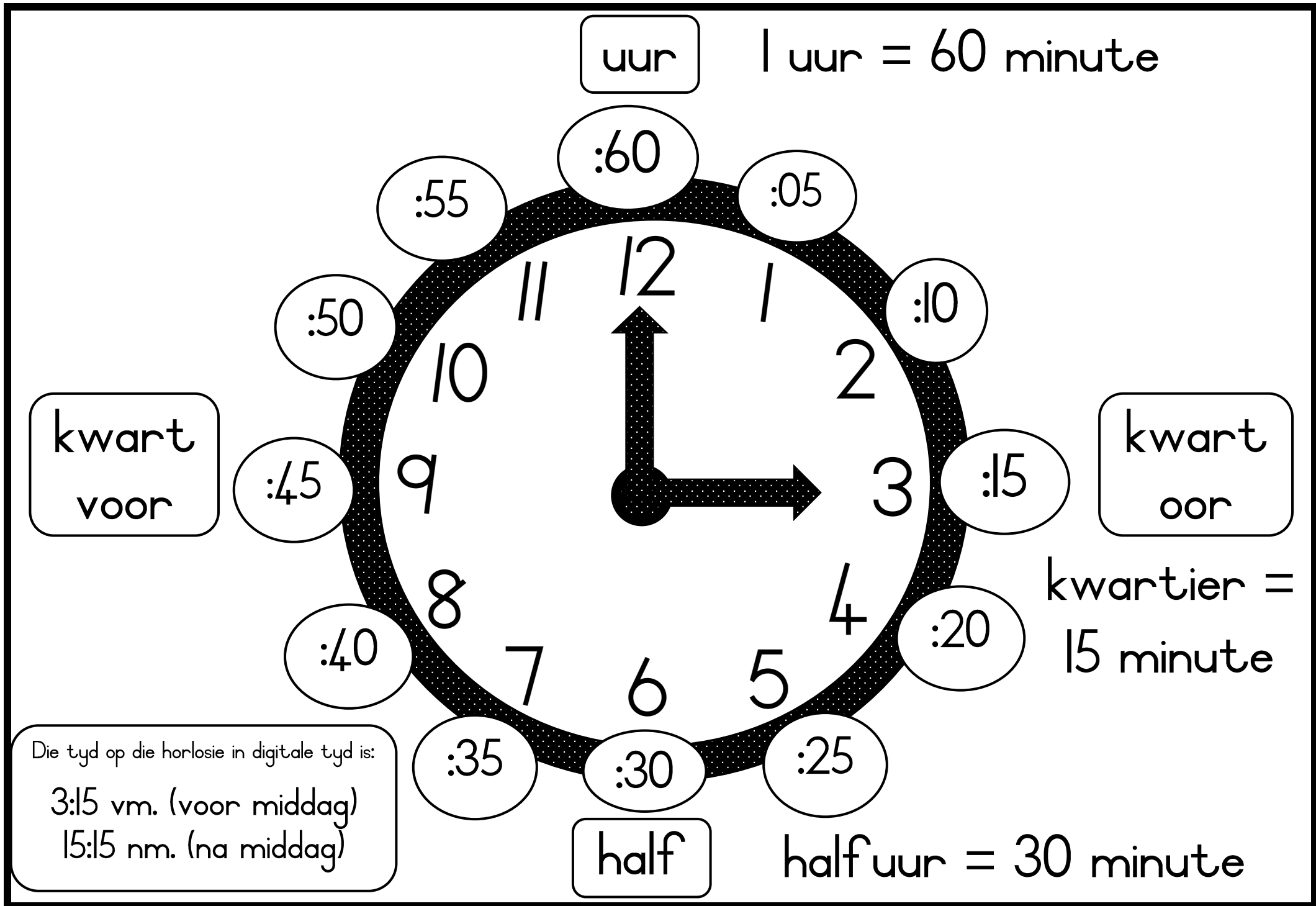

Digitale tyd - na middag

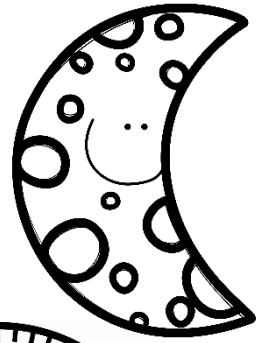

Teken die hande vir elke horlosie in nm.

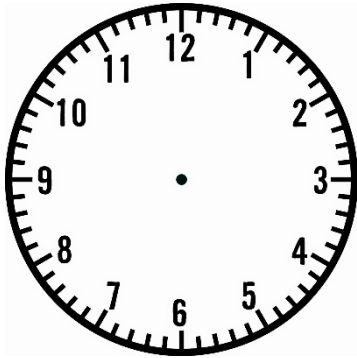

14:30

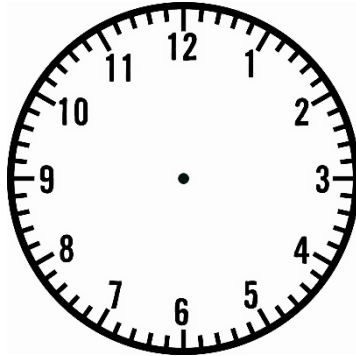

17:45

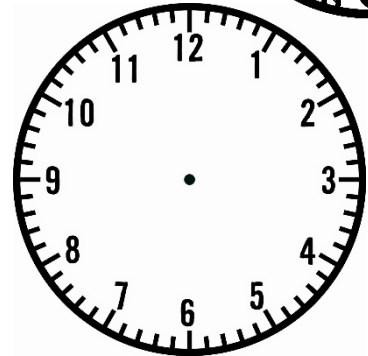

13:00

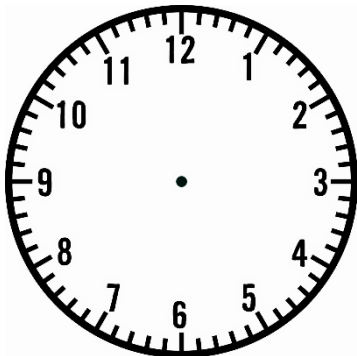

20:15

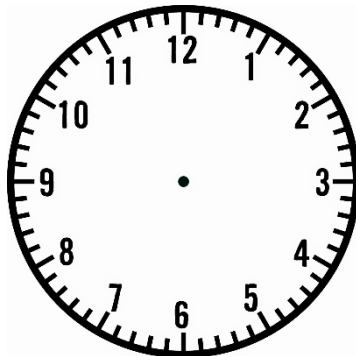

16:45

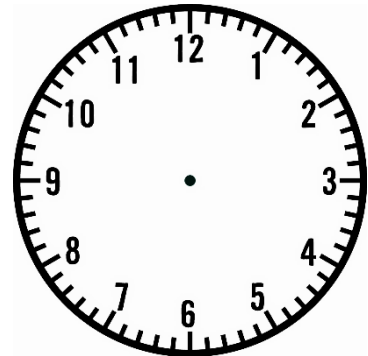

15:00

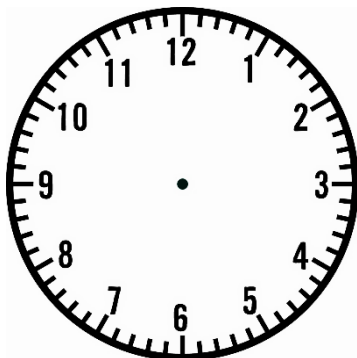

17:15

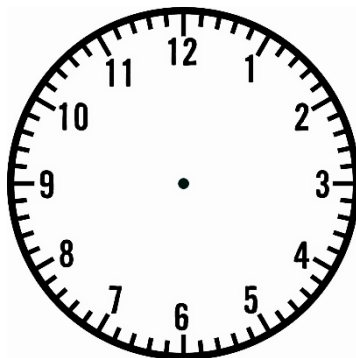

22:30

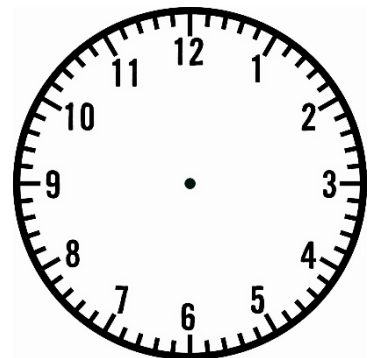

18:45

Digitale tyd - na middag

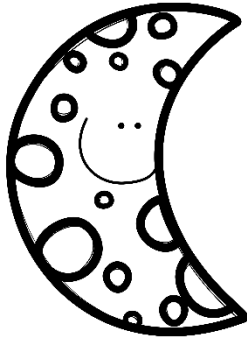

Skryf die tyd neer vir elke horlosie in nm.

9:15

11:00

7:30

2:15

10:30

2:15

9:30

12:00

Digitale tyd - voor middag

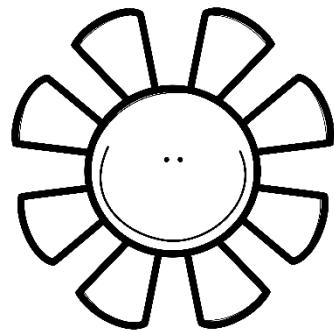

Teken die hande vir elke horlosie in vm.

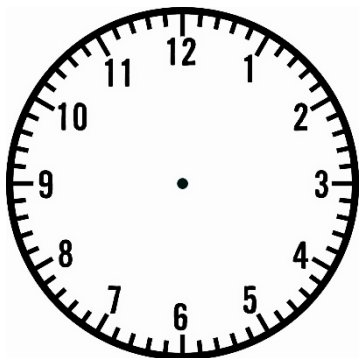

2:30

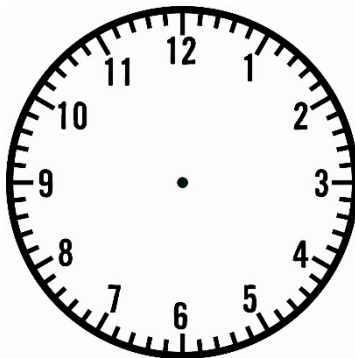

5:45

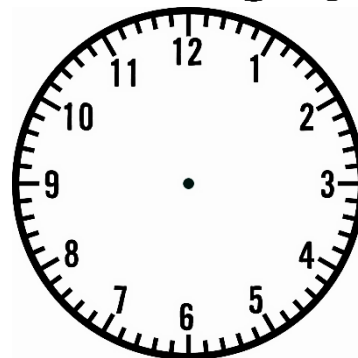

1:00

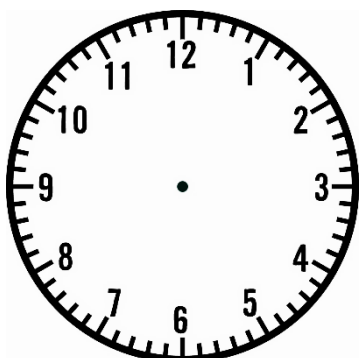

8:15

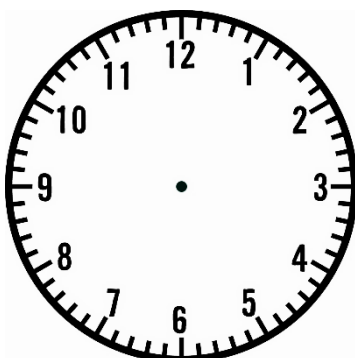

4:45

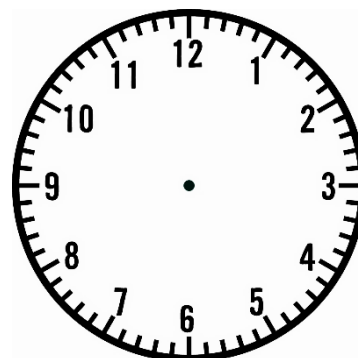

3:00

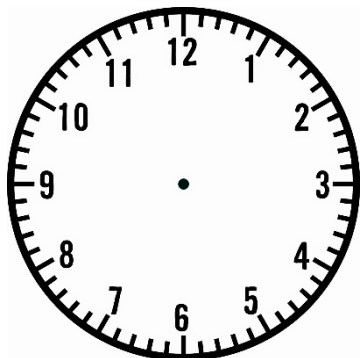

11:15

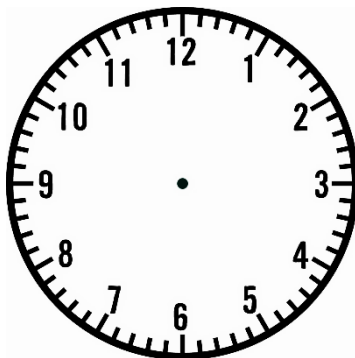

10:30

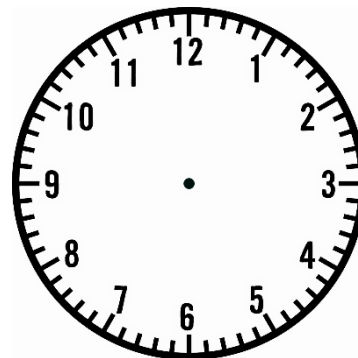

6:45

Digitale tyd - voor middag

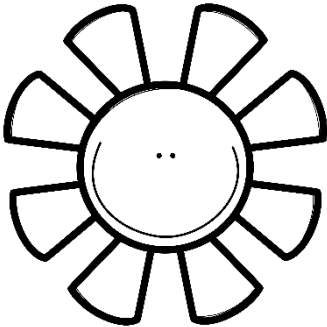

Skryf die tyd neer vir elke horlosie in vm.

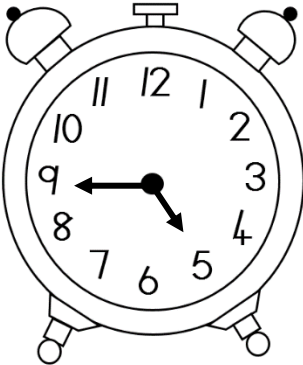

A round analog clock with two bells on top. The hour hand is between 9 and 10, and the minute hand is pointing at 4. Below the clock is a rectangular box with a colon inside, intended for writing the digital time.

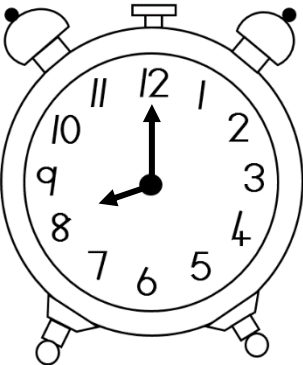

A round analog clock with two bells on top. The hour hand is pointing at 9 and the minute hand is pointing at 12. Below the clock is a rectangular box with a colon inside, intended for writing the digital time.

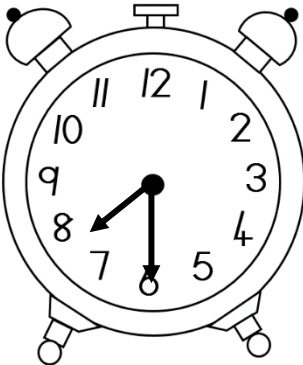

A round analog clock with two bells on top. The hour hand is between 7 and 8, and the minute hand is pointing at 6. Below the clock is a rectangular box with a colon inside, intended for writing the digital time.

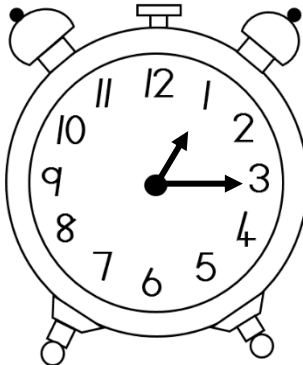

A round analog clock with two bells on top. The hour hand is between 2 and 3, and the minute hand is pointing at 3. Below the clock is a rectangular box with a colon inside, intended for writing the digital time.

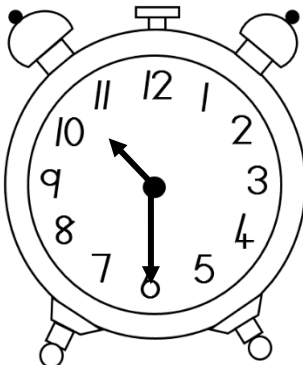

A round analog clock with two bells on top. The hour hand is between 10 and 11, and the minute hand is pointing at 6. Below the clock is a rectangular box with a colon inside, intended for writing the digital time.

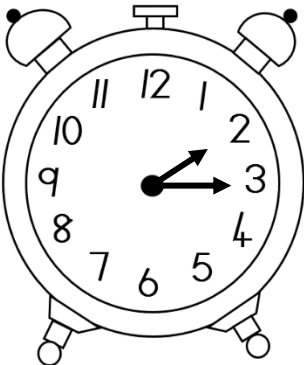

A round analog clock with two bells on top. The hour hand is between 2 and 3, and the minute hand is pointing at 3. Below the clock is a rectangular box with a colon inside, intended for writing the digital time.

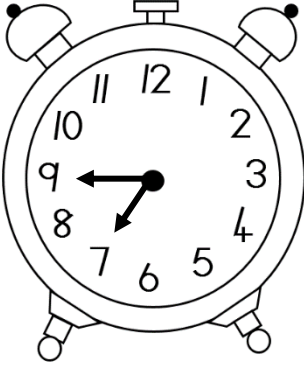

A round analog clock with two bells on top. The hour hand is between 9 and 10, and the minute hand is pointing at 6. Below the clock is a rectangular box with a colon inside, intended for writing the digital time.

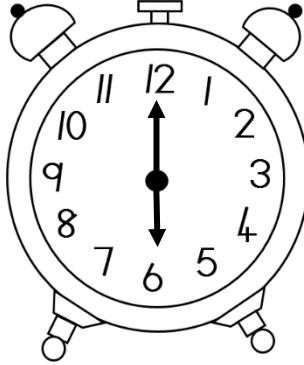

A round analog clock with two bells on top. The hour hand is pointing at 6 and the minute hand is pointing at 12. Below the clock is a rectangular box with a colon inside, intended for writing the digital time.

Tydsverloop

Gebruik die horlosies om die tydsverloop aan te dui. Dui die nuwe tyd aan deur die wysers met kleurpotlood te teken.

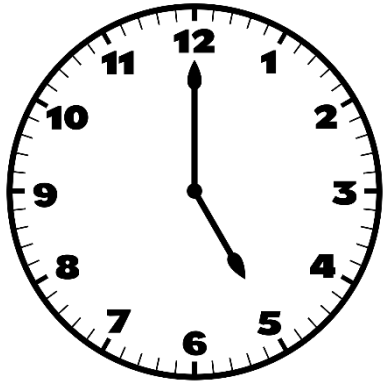

Wat sal die tyd wees oor 'n kwartier?

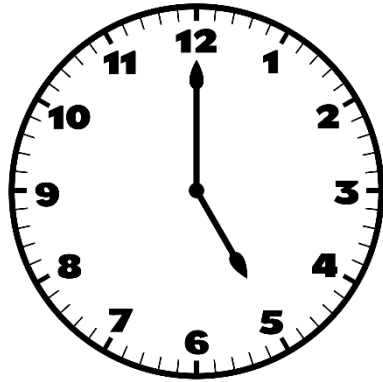

Wat sal die tyd wees oor 'n halfuur?

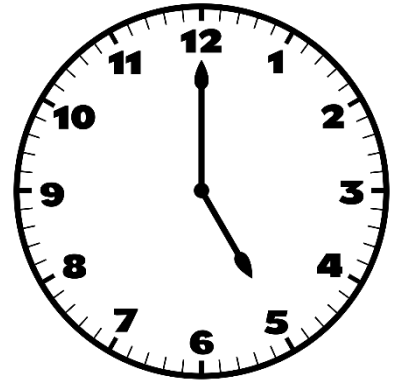

Wat sal die tyd wees oor 'n uur?

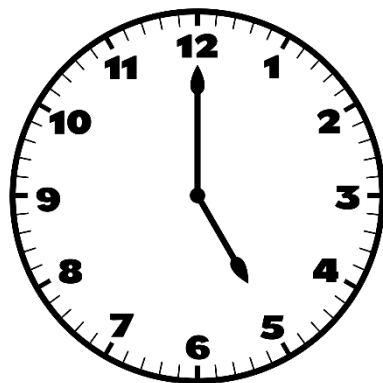

Wat sal die tyd wees oor 2 ure?

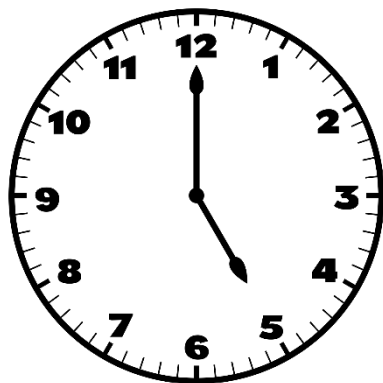

Wat sal die tyd wees oor 4 ure?

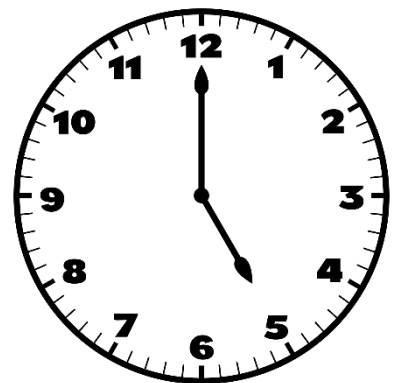

Wat sal die tyd wees oor 6 ure?

Jana het 14:15 op die bus geklim. Dit neem haar 45 minute om by die huis te kom.

Watter tyd sal Jana by die huis wees?

Teken die tyd op die horlosie.

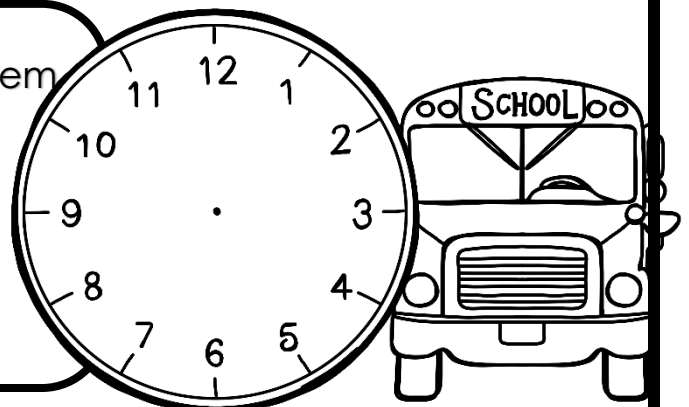

Kalender

Mei 2020						
So	Ma	Di	Wo	Do	Vr	Sa
					1	2
3	4	5	6	7	8	9
10	11	12	13	14	15	16
17	18	19	20	21	22	23
24	25	26	27	28	29	30
31						

Junie 2020						
So	Ma	Di	Wo	Do	Vr	Sa
	1	2	3	4	5	6
7	8	9	10	11	12	13
14	15	16	17	18	19	20
21	22	23	24	25	26	27
28	29	30				

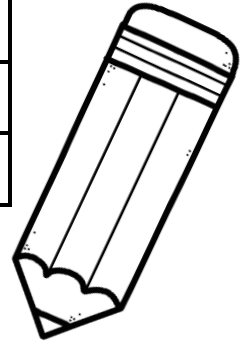

Beantwoord die vrae oor die 2 kalenders hierbo.

1. Omkring 30 Junie 2020 op die kalender.
2. A. 1 Mei is werkers dag. Kleur die dag op die kalender in.
B. Op watter dag is dit? _____
3. A. 21 Junie is vadersdag. Kleur die dag op die kalender in.
B. Op watter dag is dit? _____
4. Mia ver jaar op 12 Mei. Liam ver jaar op 20 Mei.
 - a. Kleur hulle ver jaarsdae op die kalender in.
 - b. Wie is die oudste? _____
 - c. Hoeveel dae na Mia ver jaar Liam? _____
5. Watter maand kom voor Mei? _____
6. Watter maand kom na Junie? _____
7. Watter maand is tussen Oktober en Desember? _____
8. Hoeveel dae is daar in 'n week? _____
9. Hoeveel dae is in 2 weke? _____
10. Hoeveel maande is in 'n jaar? _____
11. Hoeveel maande is daar in 2 jaar? _____
12. Hoeveel ure is daar in 'n dag?
13. Hoeveel ure is daar in 2 dae?

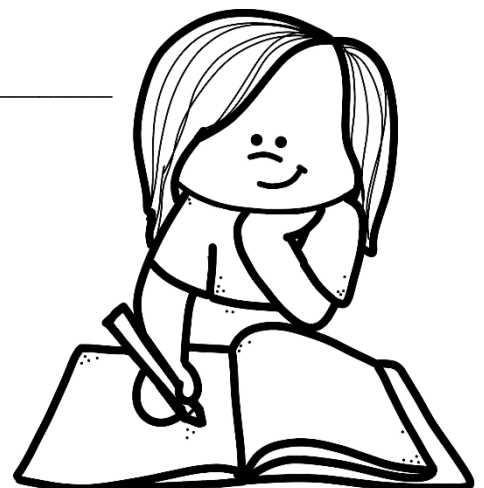



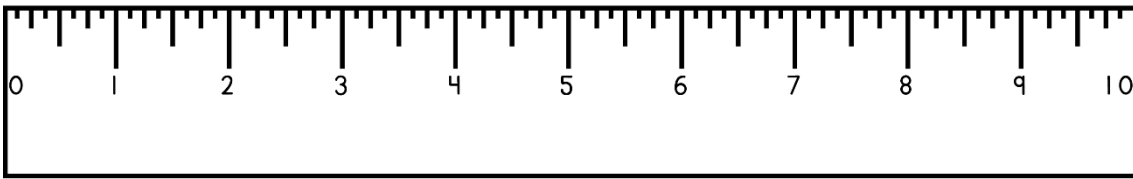

Meting in sentimeters

Die getalle op die linaal dui sentimeters aan, met die afkorting of simbool cm.

- Wanneer jy 'n linaal gebruik, begin jy by 0 meet. Party linaale wys nie die 0 nie.

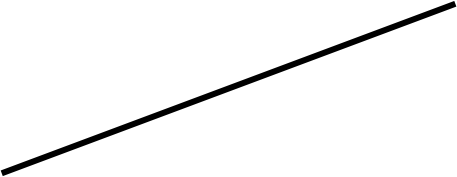
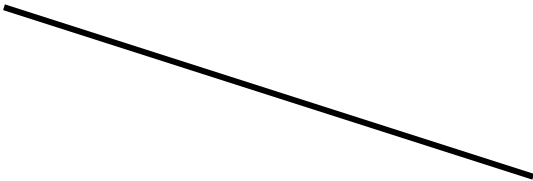

Meet die volgende lyne in sentimeter.

 <input data-bbox="600 1223 783 1339" type="text"/>	 <input data-bbox="1289 1223 1473 1339" type="text"/>
 <input data-bbox="600 1626 783 1742" type="text"/>	 <input data-bbox="1294 1626 1477 1742" type="text"/>
 <input data-bbox="600 2007 783 2123" type="text"/>	 <input data-bbox="1283 2007 1466 2123" type="text"/>

Massa

Kyk na die massas van die volgende diere.



8kg

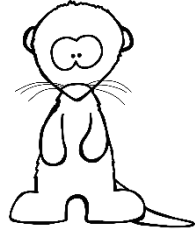

1kg



11kg



75kg

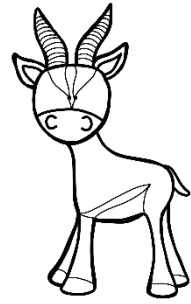









48kg

1. Skryf die massas in stygende volgorde. (ligste tot swaarste).

2. Skryf die massas in dalende volgorde. (swaarste tot ligste).

3. Voltooi die tabel deur die massas van die diere te gebruik.

	Die totaal van die diere se massas	Die verskil van die diere se massas.
 + 		
 + 		
 +  + 		
 + 		

Kapasiteit/Volume

In watter maateenheid meet ons kapasiteit/volume?

+

Kleur die aangeduide vloeistof op die maatbekers in.

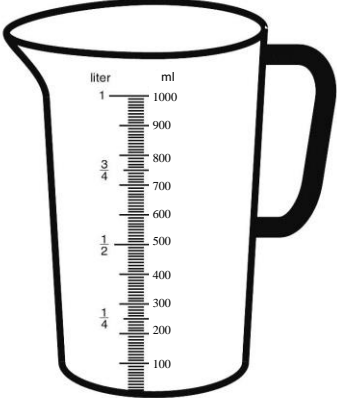
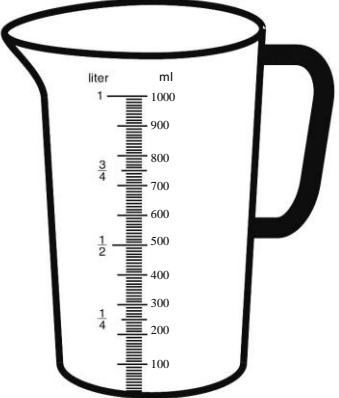
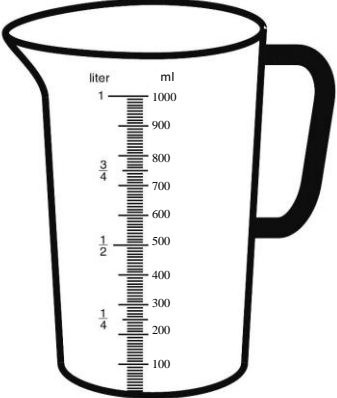
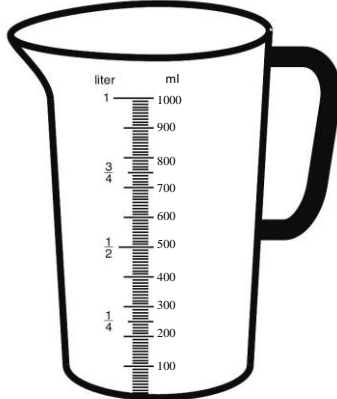
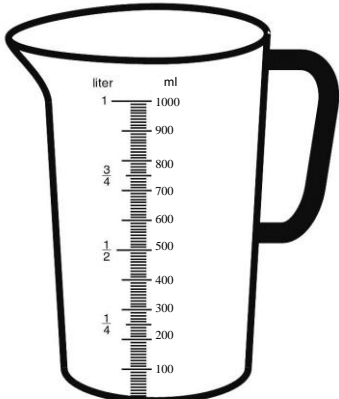
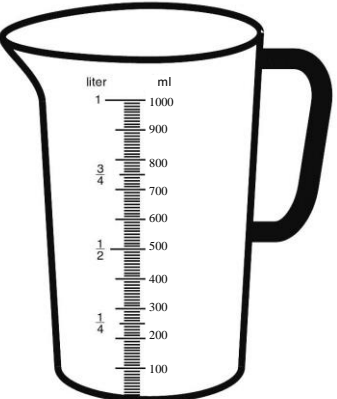
 <p>250ml</p>	 <p>330ml</p>	 <p>1 liter</p>
 <p>$\frac{1}{2}$ liter</p>	 <p>440ml</p>	 <p>200ml</p>

1. Rangskik die vloeistowwe van die meeste tot die minste.

2. Rangskik die vloeistowwe van die minste tot die meeste.

Datahantering

Bestudeer die staafgrafiek en beantwoord die vrae. Die leerders bring klomp verskillende houers na die skool. Hulle tel dan hoeveel is daar van die verskillende volume houers. Juffrou dui dit dan op 'n staafgrafiek aan.

		Volume van houers				
Aantal houers	20					
	18					
	16					
	14					
	12					
	10					
	8					
	6					
	4					
	2					
			250 milliliter	500 milliliter	750 milliliter	1 liter

- Wat is die opskrif van die staafgrafiek? _____
- Hoeveel leerders het 250 milliliter houers gebring? _____
- Hoeveel leerders het 2 liter houers gebring? _____
- Van watter volume houer was daar die meeste? _____
- Van watter volume houer was daar die minste? _____
- Van watter volume houers was daar ewe veel? _____
- Hoeveel meer 1 liter houers was daar as 750 milliliter houers?

- Hoeveel milliliter kan 'n koppie bevat? _____
- Hoeveel milliliter kan 'n teelepel bevat? _____

