

Graad 3  
Afrikaans  
Eerste Addisionele Taal

Kwartaal 4

Naam en van:

# Meervoude

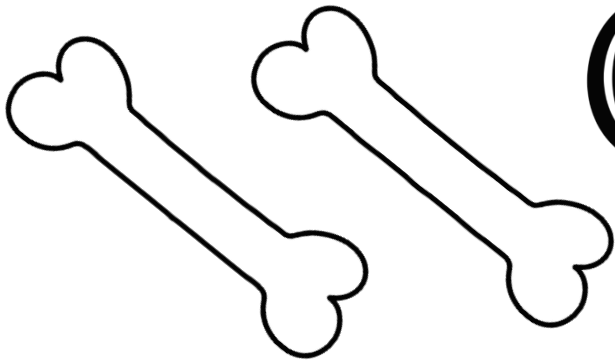

Spelreël:

Wanneer 'n woord 'n dubbelklank het, val die een klank weg en kom daar 'n e agteraan die woord.

been	bene
fopspeen	fopsene
leer	lere
geweer	gewere
naam	name
raam	rame

boom	bome
kroon	krone
spook	spoke
vuur	vure
muur	mure
skuur	skure

Spelreël:

Ons las 'n -e aan die meeste woorde wanneer ons hulle meervoud wil vorm, maar party woorde kry in die meervoud 'n -s.

piering	pierings
familie	families
leeu	lees
baba	babas
wurm	wurms

riet	riete
boek	boeke
manier	maniere

konyn	konyne
prent	prente
aarbei	aarbeie

# Meervoude

Kleur die regte antwoord in met 'n kleurpotlood.

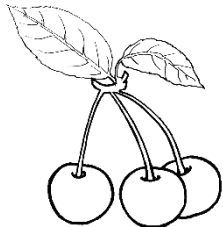

kersies

kersie

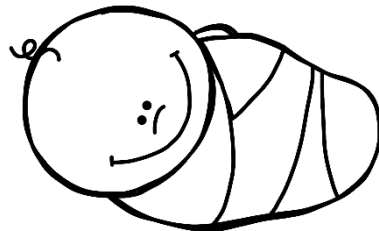

baba

babas

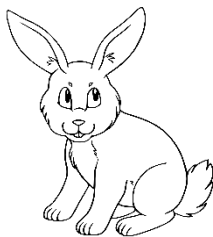

konyn

konyne

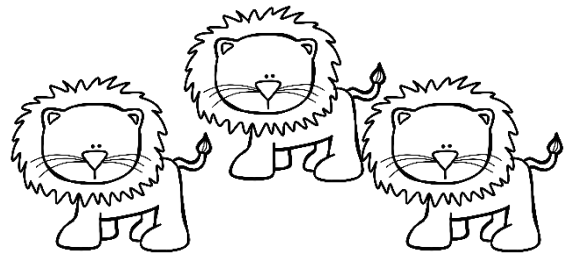

leeus

leeu

Skryf die meervoude van die volgende woorde.

	Meervoud
boek	
piering	
hondjie	
aarbei	
kersie	
wurm	

	Meervoud
baba	
riet	
familie	
been	
leeu	
fopspeen	

# Verkleinwoorde

Spelreël:

- Party woorde wat op -ng eindig, verloor die -g in die verkleiningsvorm en kry -kie by.
- Tweelettergrepige woorde kry 'n -kie.

doring	dorinkie
toring	torinkie
woning	woninkie
horing	horinkie
koning	koninkie
varing	varinkie

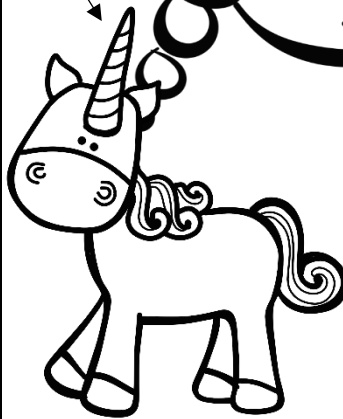

Spelreël:

- Party woorde wat op -ng eindig, kry in die verkleiningsvorm -et jie.
- Eenlettergrepige woorde kry 'n -et jie.

ding	dinget jie
ring	ringet jie
gang	ganget jie
tang	tanget jie
string	stringet jie
kring	kringet jie



# Verkleinwoorde

skoen	skoent jie
blaar	blaart jie
skool	skoolt jie
trui	truit jie
stoel	stoelt jie
broer	broert jie
swaai	swaait jie
trein	treint jie
seun	seunt jie

Spelreël:  
Baie woorde kry -t jie in die verkleiningsvorm

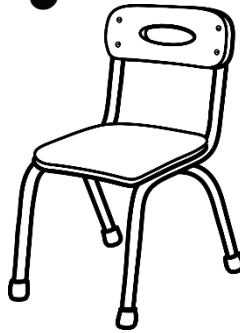

Spelreël:  
Woorde wat op -t eindig, kry in die verkleiningsvorm altyd 'n -jie.



straat	straat jie
maat	maat jie
kat	kat jie
mat	mat jie
prent	prent jie
voet	voet jie
slot	slot jie
poot	poot jie
ruit	ruit jie

# Verkleinwoorde

lag	laggie
bos	bossie
krap	krappie
hek	hekkie
brug	bruggie
vlag	vlaggie
bus	bussie
tak	takkie
kas	kassie

Spelreël:  
 Wanneer 'n woord 'n kort klinker in die middel het, verdubbel die slotmedeklinker in die verkleiningsvorm en kom -ie by.

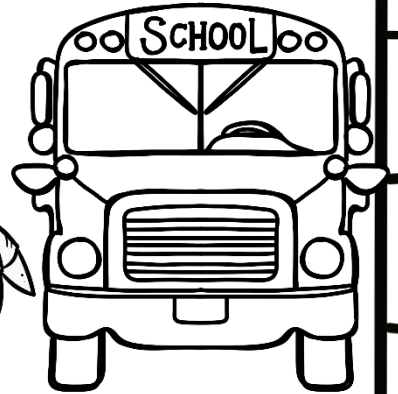
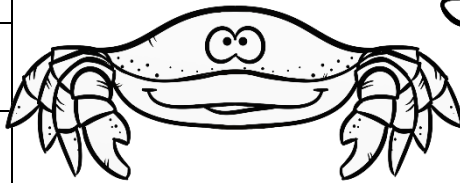

Spelreël:  
 Woorde wat op -m eindig, kry in die verkleiningsvorm altyd 'n -pie.



duim	duimpie
rym	rympie
raam	raampie
room	roompie
droom	droompie
soom	soompie
naam	naampie
arm	armpie
boom	boompie

# Verkleining

Help die pikkewyne om die verkleiningsvorm van die volgende woorde te skryf.

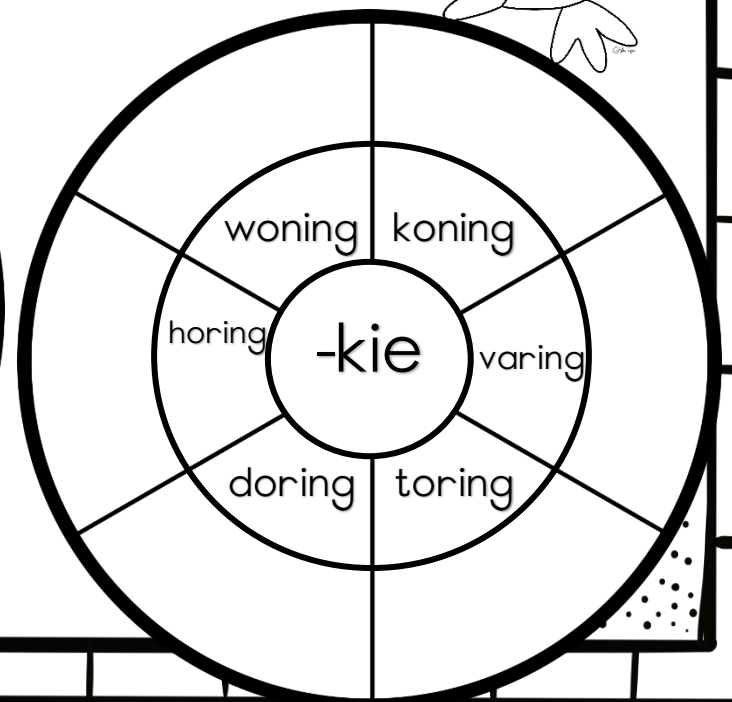
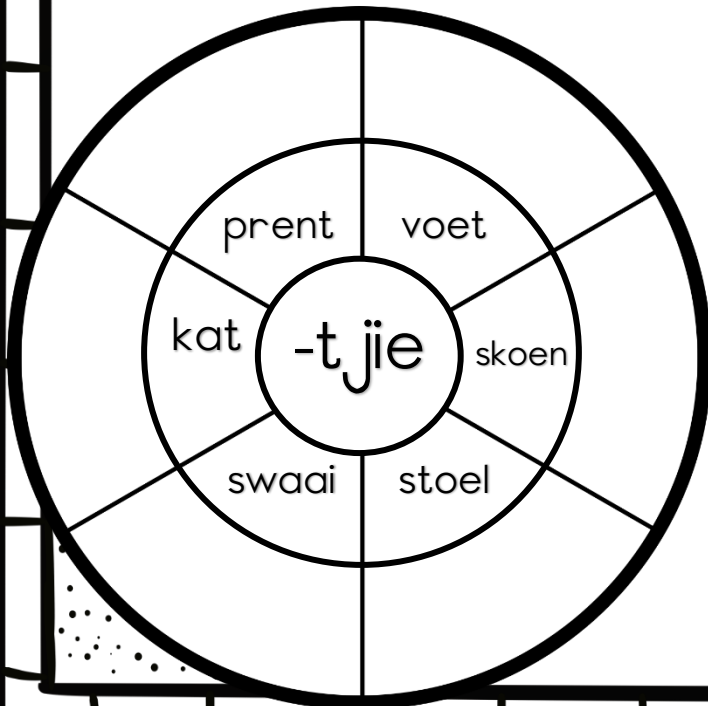
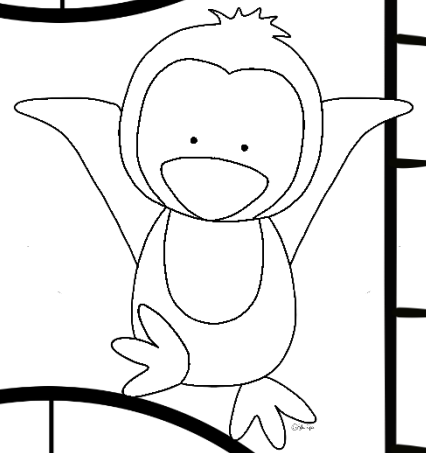
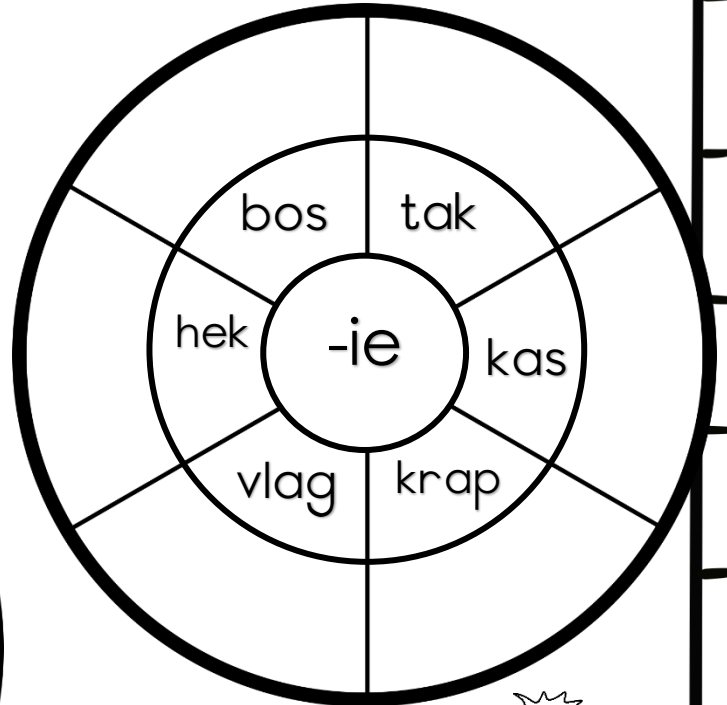
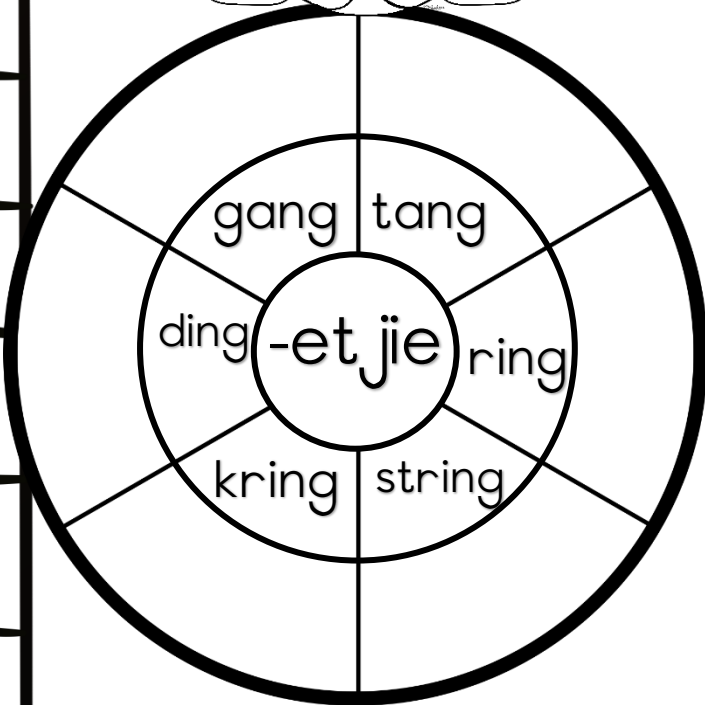

Teenwoordige tyd - Dit verwys na die hede.

Verlede tyd - Dit verwys na tyd wat verby is.

Teenwoordige tyd	Verlede tyd
sal	sou
is	was
moet	moes
eet	geëet
val	geval
voer	gevoer
voel	gevoel
kry	gekry
stry	gestry
rem	gerem
gee	gegee
gaan	gegaan
groei	gegroei
skop	geskop
staan	gestaan
weeg	geweeg

Teenwoordige tyd	Verlede tyd
wil	wou
kan	kon
het	gehad
word	geword
weet	geweet
bly	gebly
veg	geveg
sien	gesien
stop	gestop
slaap	geslaap
spat	gespat
skrop	geskrop
vee	gevee
swem	geswem
sit	gesit
maak	gemaak

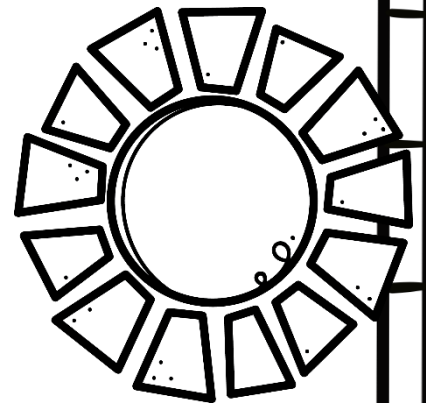

# Verlede tyd

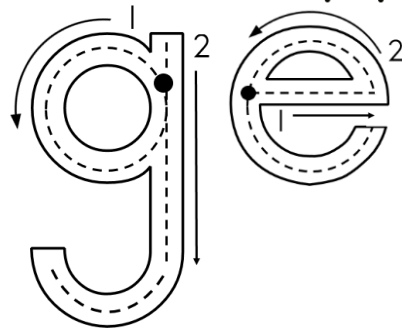

Ons gebruik die verlede tyd as iets klaar gebeur het.

Ons sit dan 'n "ge" vooraan die woord.



byvoorbeeld:  
**ge + spring =  
gespring**

Verbind die woorde in die teenwoordige tyd met die regte woord in die verlede tyd.

was

sien

rus

werk

slaap

gaan

gegaan

gesien

gewas

gerus

gewerk

geslaap

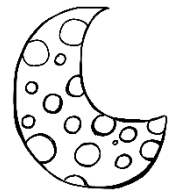

Onderstreep die regte woord in elke sin.

1. Gisteraand het ek die maan gesien/sien.
2. Nou sien/gesien ek die son.
3. Gister het Ben vir Anna 'n bal bring/gebring om te gooi.
4. Ons gaan/gegaan elke oggend skool toe.
5. Elke aand gebring/bring Sant jie se ma vir haar melk kamer toe.
6. Ek het vanoggend pap vir ontbyt geëet/eet.



# Verlede tyd



In die verlede tyd gebruik ons die woord **gister, het of was**.



In die verlede tyd sit ons 'n **"ge"** vooraan die werkwoord, bv. gespeel.

Skryf die volgende sinne in die verlede tyd deur met die woord "Gister" te begin.

Ek eet 'n stukkie koek.

Ek en my boetie speel blokkies.

Mamma koop vir my mooi skoene.

Ouma bak koek vir my verjaarsdag.

Onderstreep die regte woord in elke sin.

1. Gister het/sal ek by my maat gespeel/gaan speel.
2. Mōre het ek skool toe gegaan/sal ek skool toe gaan.
3. Verlede week het ek/sal ek by my oupa en oupa gaan kuier/gekuier.
4. Tydens die wedstryd het/sal dit begin reën/gereën.



# Verlede tyd

## Teenwoordige tyd

Skryf die woorde in die sonne wat in die verlede tyd is by die woorde in die teenwoordige tyd in die tabel.

vlieg	
praat	
is	
spat	
eet	
het	
val	
kry	
koop	

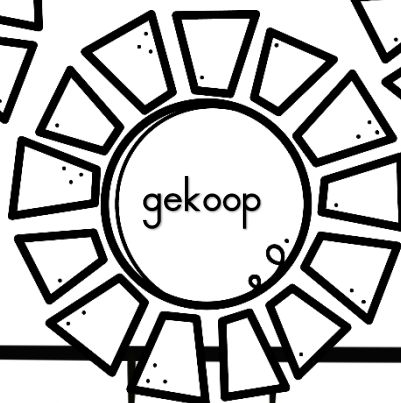
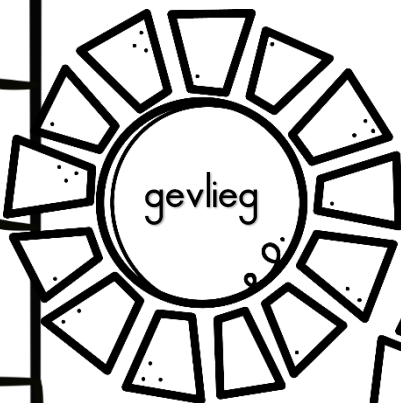
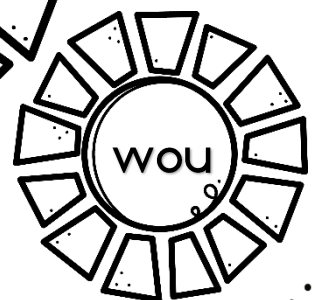
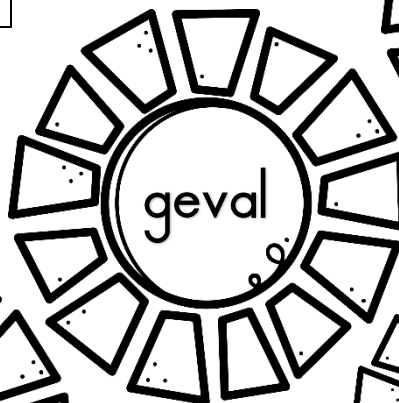
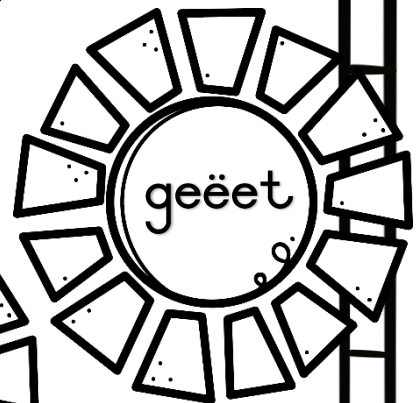
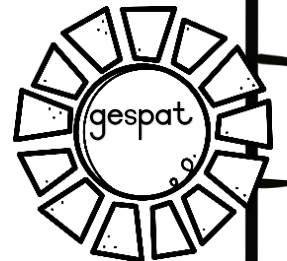
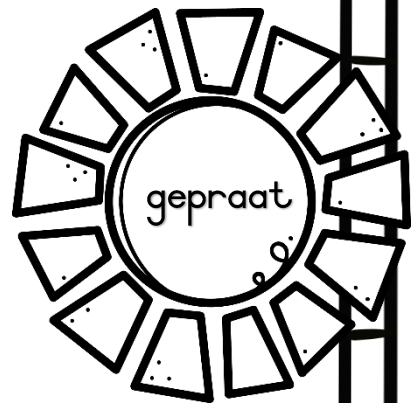
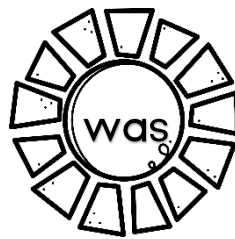

# Verlede tyd

## Teenwoordige tyd

Gebruik die werkwoorde om die volgende sinne te voltooi en skryf of die sin in die teenwoordige tyd of verlede tyd is.

<div style="display: flex; flex-direction: column; align-items: center;"> <div style="border: 1px solid black; border-radius: 10px; padding: 5px; margin-bottom: 10px;">loop</div> <div style="border: 1px solid black; border-radius: 10px; padding: 5px; margin-bottom: 10px;">geloop</div> <div style="border: 1px solid black; border-radius: 10px; padding: 5px;">het</div> </div>	Jana <u>loop</u> elke dag skool toe.	teenwoordige tyd
	Verlede week _____ Jaco dorp toe _____.	

<div style="display: flex; flex-direction: column; align-items: center;"> <div style="border: 1px solid black; border-radius: 10px; padding: 5px; margin-bottom: 10px;">gesing</div> <div style="border: 1px solid black; border-radius: 10px; padding: 5px; margin-bottom: 10px;">het</div> <div style="border: 1px solid black; border-radius: 10px; padding: 5px;">sing</div> </div>	Ben _____ in die koor _____.	
	Klara _____ in die koor.	

Onderstreep al die woorde wat in die verlede tyd is met groen.

Ben het 'n nuwe fiets gehad,  
hy het dit ongelukkig geleen vir sy maat.  
Die fiets is toe gesteel.  
Ben sit nou met 'n groot knop in sy keel.  
Hy gaan nie weer vinnig 'n fiets deel.  
Dit was die mooiste fiets,  
sy pa gaan hom definitief piets.

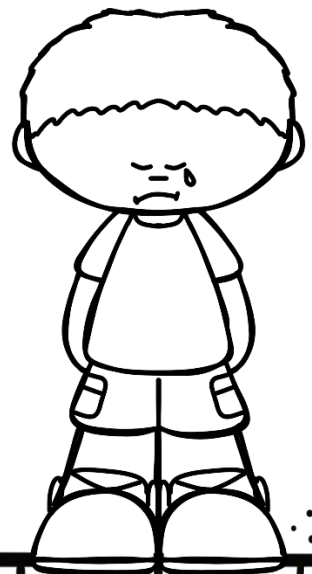



# Toekomende tyd

Skryf elkeen van die sinne oor deur die sin met **Môre** te begin.

Ek eet my kos.

Môre sal ek my kos eet.

Ek gaan na Ester toe.

Ek speel met Ester.

Ons ry in 'n trein.

Oupa plant blomme in die tuin.

Ek doen my huiswerk.

# Werkwoord

'n Werkwoord is 'n "doenwoord".

Onderstreep die werkwoord in elke sin met 'n kleurpotlood.

1. Die padda eet 'n vlieg.
2. My boetie speel met 'n bal.
3. Die bruin hond kou 'n been.
4. My maat Jannie sit langs my in die klas.
5. Die man bestuur die bus.
6. Klara dra 'n mooi rokkie.



Voltooi die sinne deur die werkwoorde in te vul:

1. Ben \_\_\_\_\_ die bal baie ver.
2. Die man \_\_\_\_\_ oor die pad.
3. Liezl \_\_\_\_\_ graag na stories.
4. My pa gaan \_\_\_\_\_ elke middag 10km.
5. Mamma \_\_\_\_\_ lekker vir pappa se grappie.
6. Jana \_\_\_\_\_ vreeslik baie.

draf

loop

praat

luister

lag

skop

# Byvoeglike naamwoord

'n Byvoeglike naamwoord vertel ons meer van die selfstandige naamwoord. Byvoeglike naamwoorde is woorde wat dinge beskryf. Byvoorbeeld: My pa ry 'n rooi kar.

Vul die byvoeglike naamwoorde in die blokkiesraaisel in. Lees die leidrade,

1

ou

2

3

4

5

6

hartseer

groot

gawe

slim

groen

heerlike

DWARS

2 Die \_\_\_\_\_ boom het rooi appels.

3 Die \_\_\_\_\_ seun het sy tas verloor.

5 Die \_\_\_\_\_ man het grys hare.

6 Die \_\_\_\_\_ seun het sy kos met my gedeel.

AF

1 Ons eet \_\_\_\_\_ kos.

2 Die \_\_\_\_\_ olifant weeg 6000kg

4 Die \_\_\_\_\_ meisie het 90% op haar rapport gekry.

# Selfstandige naamwoord

- Selfstandige naamwoorde is die name van mense, dinge en plekke.
- 'n Selfstandige naamwoord is iets waaraan jy kan vat.

Kyk of jy die selfstandige naamwoorde in die sinne kan kry.  
Omkring dit met 'n kleurpotlood.

1. Werner het 'n blou fiets vir sy verjaarsdag gekry.
2. Lenie het 'n bruin beertjie by die kompetisie gewen.
3. Klara het twee klein, swart honde.
4. Juffrou hou baie van sjokolade koek.
5. Die vriendelike tannie het vir my gewaai.

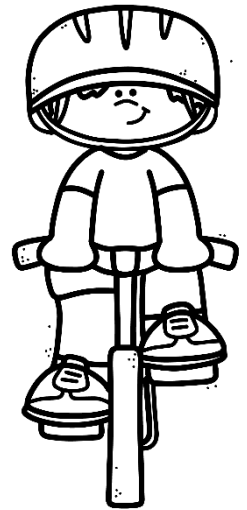

Lees die sinne hierbo en skryf al die byvoeglike naamwoorde neer.

# Werkwoorde

Byvoeglike naamwoorde

Selfstandige naamwoorde

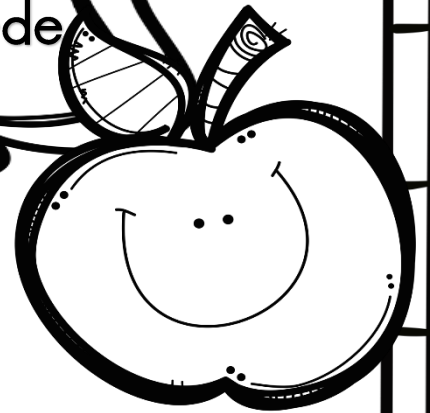

Kleur die appels op die volgende manier in:

- Kleur die werkwoorde met blou in.
- Kleur die byvoeglike naamwoorde met pers in.
- Kleur die selfstandige naamwoorde met groen in.

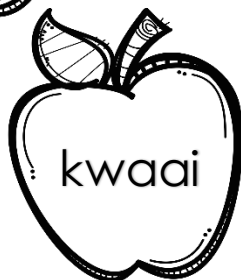
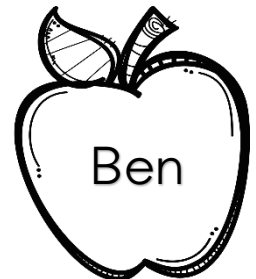
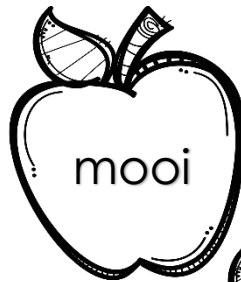
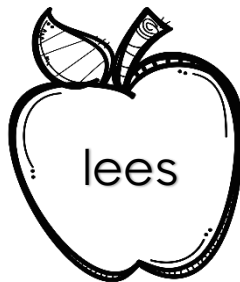
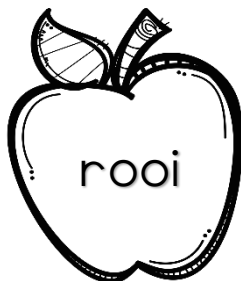
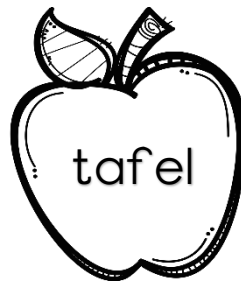

# Rymwoorde

Rymwoorde se  
eindklanke klink  
dieselfde.

Kyk na die legkaart stukke op die volgende bladsy. Soek elk legkaart se stuk wat met hom rym. Knip die twee stukke uit en pla dit in die blok hieronder. Daar is solank vir jou 'n voorbeeld geplak.

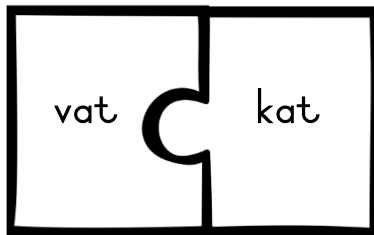

weet

muis

boek

mou

skreeu

been

sneeu

huis

een

soek

kou

vergeet

# Direkte rede

Die direkte rede is iemand se direkte woorde, bv.:  
Hy vra: "Kan ek jou help?"

Skryf die volgende sinne in die direkte rede. Onthou om aanhalingstekens te gebruik.



Het jy die vakansie geniet?

Johan het gevra: " \_\_\_\_\_  
\_\_\_\_\_  
\_\_\_\_\_

Jana het geantwoord: " \_\_\_\_\_  
\_\_\_\_\_  
\_\_\_\_\_

Ja, ons was by die see.

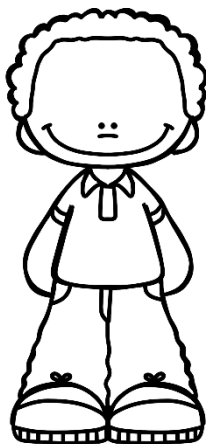
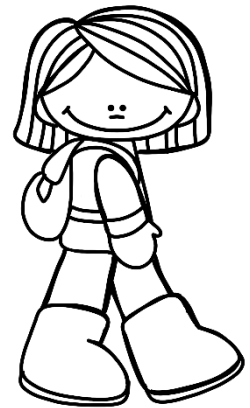

Ek wens ek kon ook see toe gaan.

Willem het gesê: " \_\_\_\_\_  
\_\_\_\_\_  
\_\_\_\_\_



# Voornaamwoorde

Gebruik die voornaamwoorde in die sirkels om die sinne te voltooi.

1. Hy het \_\_\_\_\_ huiswerk gedoen.
2. Ek lees \_\_\_\_\_ boek.
3. Sy het \_\_\_\_\_ boek skool toe geneem.
4. Ons het \_\_\_\_\_ boeke.
5. Hulle het \_\_\_\_\_ aandete geëet.
6. Ek het \_\_\_\_\_ middagete geëet.
7. Jy moet \_\_\_\_\_ huiswerk doen.
8. Ons het \_\_\_\_\_ huiswerk gedoen.
9. Sy soek \_\_\_\_\_ potlood.
10. Jy het \_\_\_\_\_ potlood.
11. Hy het volpunte vir \_\_\_\_\_ toets gekry.
12. Hulle het \_\_\_\_\_ huiswerk gedoen.

haar

ons

hulle

sy

jou

my

'n Voornaamwoord  
staan in die plek van  
'n naamwoord.



# Voorsetsels

tussen

onder

naby

oor

in

op

Voorsetsels is woorde  
wat die posisie van  
dinge aandui.

Gebruik die woorde in die blokkies om die sinne te voltooi.

1. Die kat jies het \_\_\_\_\_ die kas weggekruip.
2. Die hond jie het \_\_\_\_\_ die tafel gesit.
3. Pam het \_\_\_\_\_ Anita en Jabu gesit.
4. Die olifant het \_\_\_\_\_ die heuwel geloop.
5. Die seun lê \_\_\_\_\_ die tafel.
6. Ons woon \_\_\_\_\_ die skool.

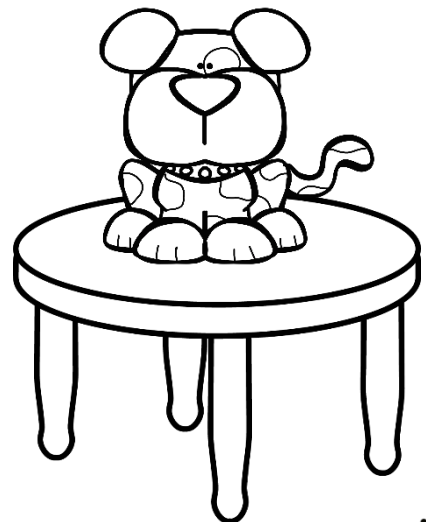
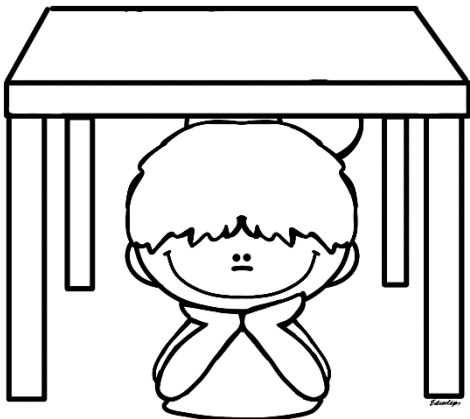

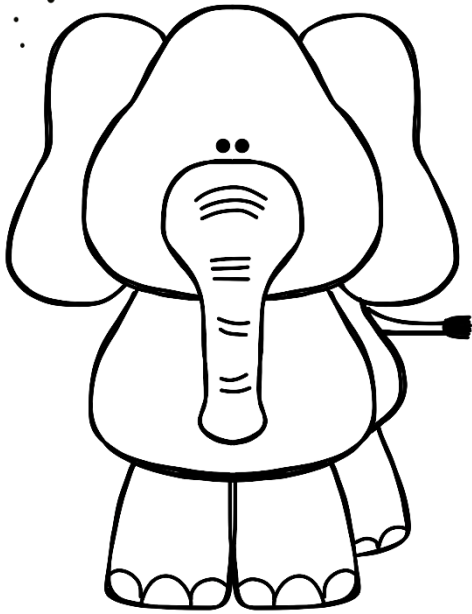

# Homofone

Homofone klink dieselfde, maar word verskillend gespel en het verskillende betekenis.

Onderstreep die regte woord in elke sin.

1. Olifante kan oor 'n steil/styl bult klim.
2. Die olifant sukkel om in die grond te grawe, want dit is baie hart/hard.
3. Ek wed/wet jou die olifantma gaan die kleintjie se stert vat.
4. Olifante het fier/vier maaltande.
5. Daar is 'n wond aan die matriarg se hak/haak.
6. Olifante verkeer in noot/nood omdat hulle deur jagters doodgemaak word.
7. Die olifant vlei/vly haar op die groen gras neer.
8. Ek dink juffrou se hare is in 'n mooi steil/styl gesny.
9. Hy hou baie van die bont/bond hond.
10. Die bal is hart/hard gepomp.
11. Ouma lei/ly aan suikersiekte.
12. Die gesin gaan 'n groter huis soek om te hier/huur.

# Trappe van vergelyking



Ons noem die verbuiging van byvoeglike naamwoorde "trappe van vergelyking".

warm	warmer	warmste
hoog	hoër	hoogste
lank	langer	langste
sterk	sterker	sterkste
groot	groter	grootste
klein	kleiner	kleinste
soet	soeter	soetste
kort	korter	kortste
lekker	lekkerder	lekkerste
sag	sagter	sagste
min	minder	minste
swaar	swaarder	swaarste
mooi	mooier	mooiste
slim	slimmer	slimste
vinnig	vinniger	vinnigste





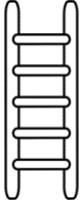
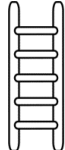

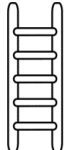
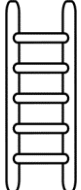

# Trappe van vergelyking

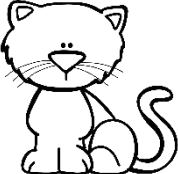
Voltooi die trappe van vergelyking.



		
		kortste

		
	langer	

		
		kleinste

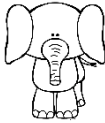
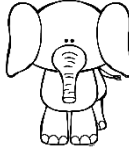
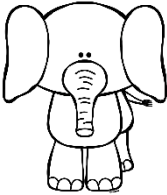
		
min		

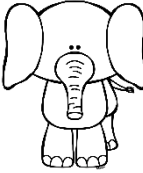
		
groot		

		
	swaarder	

Skryf die woorde in trappe van vergelyking.

	-er	-ste
groot		
mooi		
sterk		
sag		
slim		

# Antonieme

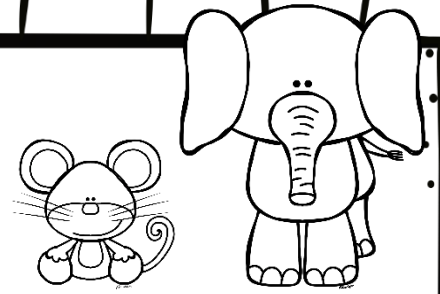

Onthou jy nog wat 'n antoniem is? 'n Antoniem is 'n woord met die teenoorgestelde betekenis as 'n ander woord.

naby	ver
koop	verkoop
breed	smal
bly	hartseer
skoon	vuil
groot	klein
vol	leeg

dag	nag
oop	toe
wit	swart
regop	onderstebo
voorkant	agterkant
bo-op	onder
binne	buite

# Sinonieme



Onthou jy nog wat 'n sinoniem is? Dit is 'n woord wat dieselfde betekenis as 'n ander woord het.

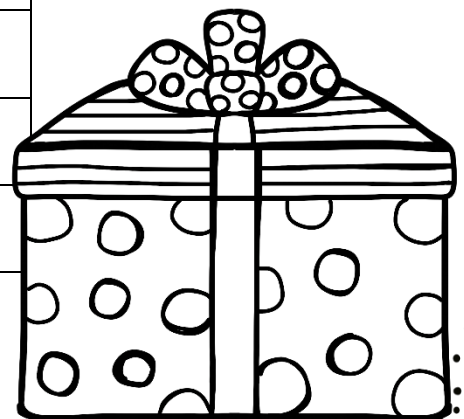

lekker	heerlik
pragtig	mooi
spyt	jammer
present	geskenk

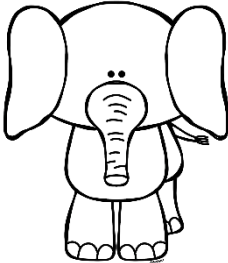

# Antonieme en Synonieme

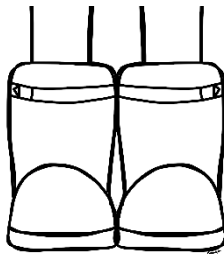

Voltooi die antonieme.

	
groot	

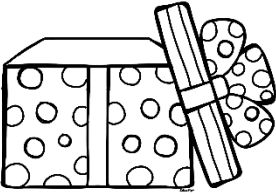
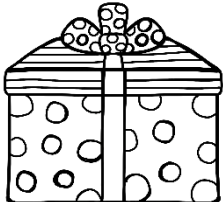
	
	vuil

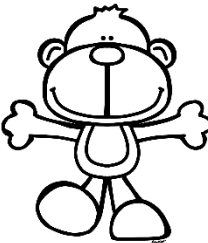
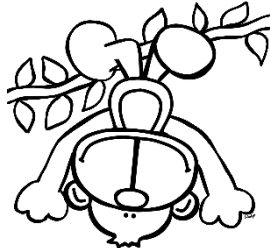

Voltooi die sinonieme.

lekker	
pragtig	
spyt	
present	

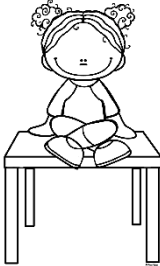
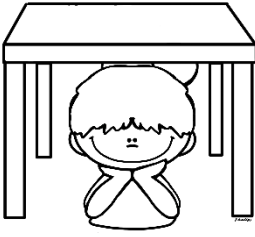
# f en v- woorde

Onderstreep die f en v-klank.

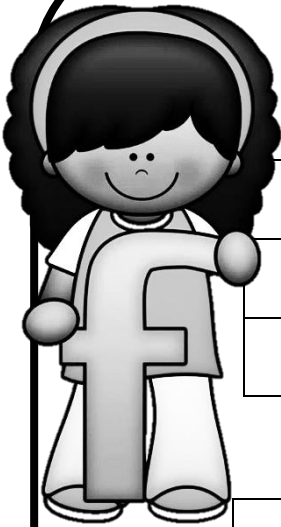

## f-woorde

familie	frons	flamink	fiets
straf	weef	vryf	
dief	af	self	

## v-woorde

vis	voet	vuur	val	vark
vrugte	vra	vryf	vaak	vroliek

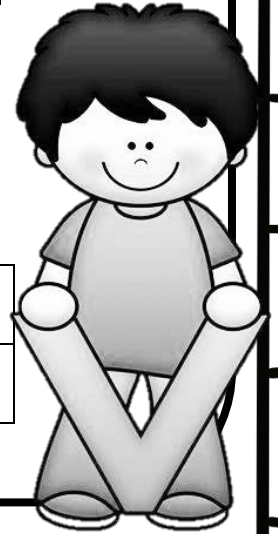

Onderstreep die woord met die regte spelling.

1. Ek vryf / fryf my hond as ek by die huis kom.
2. My pa strav / straf my as ek ongehoorsaam is.
3. Appels is my gunsteling vrug / frug.
4. As ek te laat wakker bly is ek die volgende dag faak / vaak.
5. Die dief / diev het ons kar gasteel.
6. 'n Mens gaan fal / val as jy nie kyk waar jy loop nie.
7. Ek het self / selv die skottelgoed gewas.



# f en v- woorde

Kyk na die onderstaande woorde met prent jies en besluit of dit met 'n f of 'n v geskryf moet word.

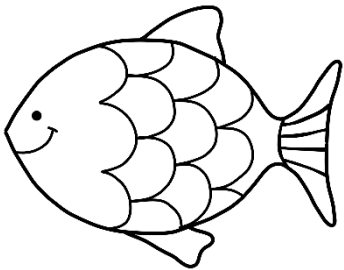

\_\_\_is



\_\_\_amilie

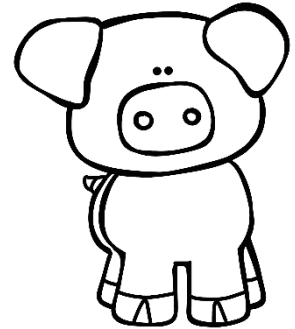

\_\_\_ark

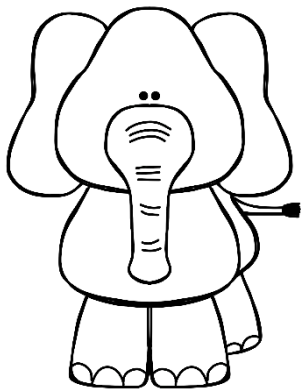

oli\_\_\_ant



\_\_\_oet

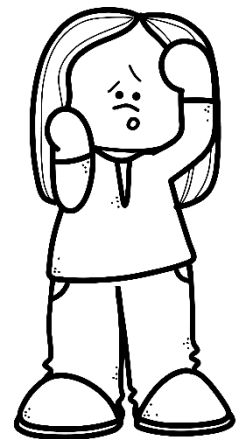

\_\_\_rons

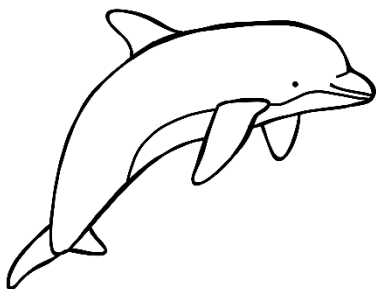

dol\_\_\_yn



\_\_\_uur

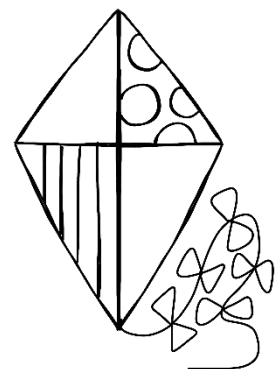

\_\_\_leër

Gebruik die klanke om die woorde te voltooi.

a, e, i, o, u

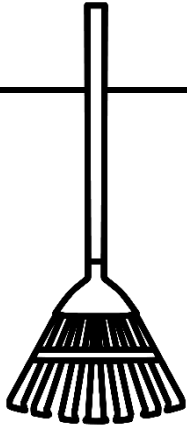

h\_\_rk

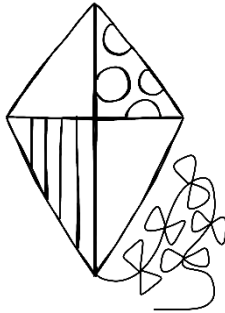

vl\_\_eër



k\_\_rs

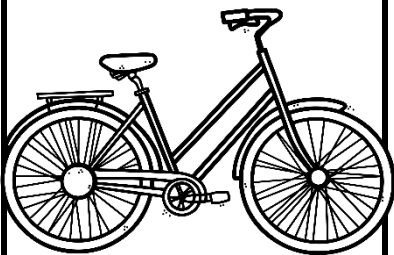

fi\_\_ts

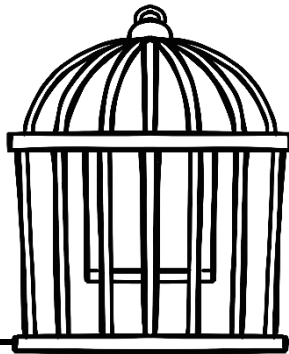

h\_\_k



b\_\_nd

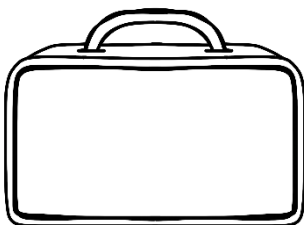

t\_\_s

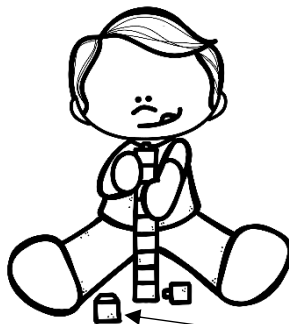

bl\_\_k



k\_\_rk

# ui-klank

Oefen om die klank te skryf.

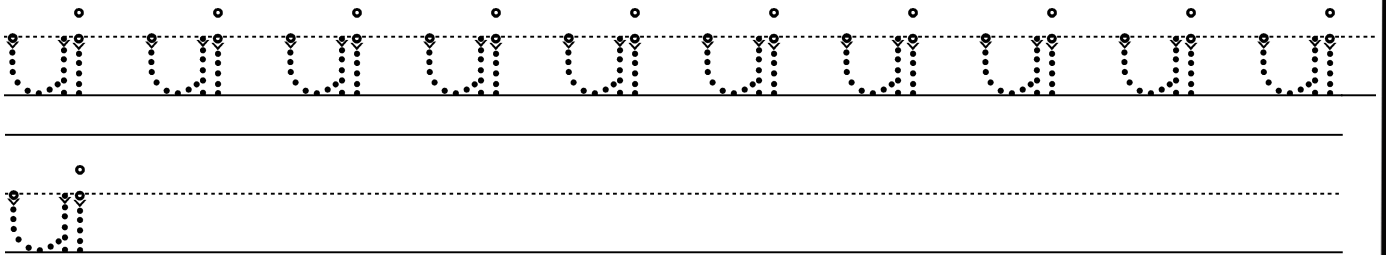
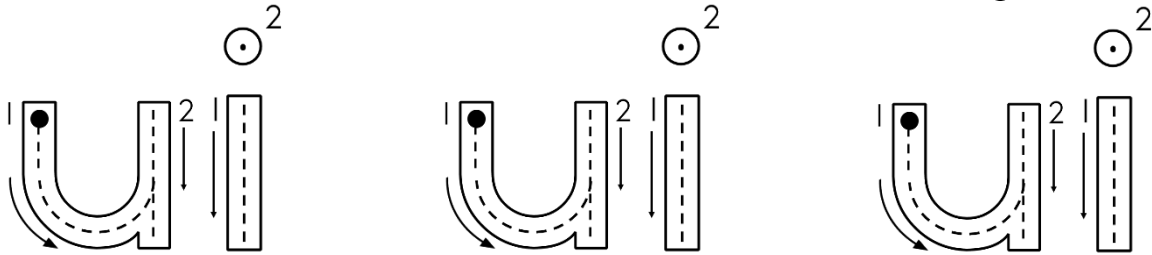

Lees die woorde. Onderstreep die ui-klank.

uil	huil	duim
vuil	juig	muis
vuis	huis	kruis
tuin	trui	

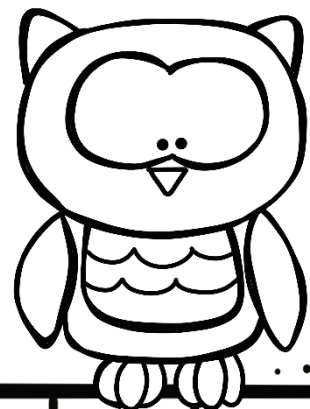

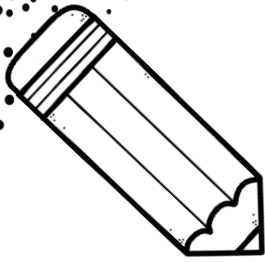



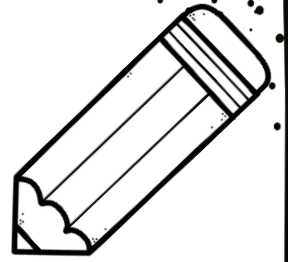



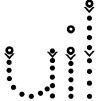











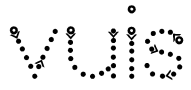

# ui-klank

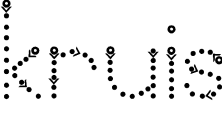

Lees en skryf die woorde.

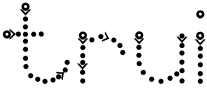
	uil		
	huil		
	vuil		
	juig		
	duim		
	muis		
	vuis		
	huis		
	kruis		
	tuin		
	trui		



# ie-klank



Oefen om die klank te skryf.

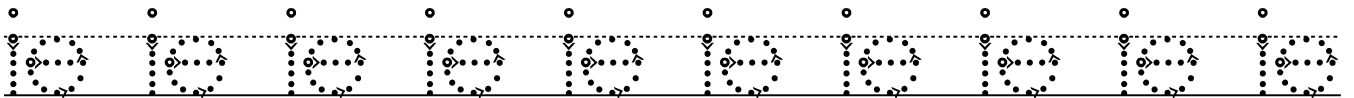
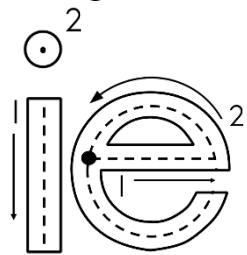
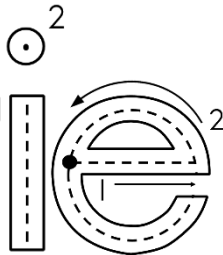
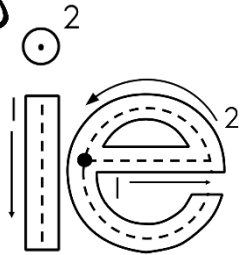

Lees die woorde. Onderstreep die ie-klank.

tier	mier	drie
vier	tien	siek
nies	lief	kiem
dier	wiel	sien
riet	kies	fiets

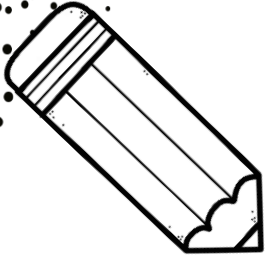

# ie-klank

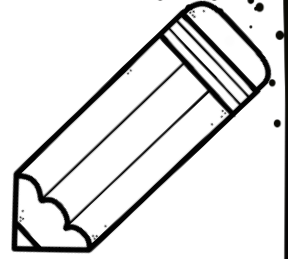

Lees en skryf die woorde.

 tier	tier	
 mier	mier	
 drie	drie	
 vier	vier	
 tien	tien	
 siek	siek	
 nies	nies	
 fiets	fiets	
 wiel	wiel	
 dier	dier	
 sien	sien	

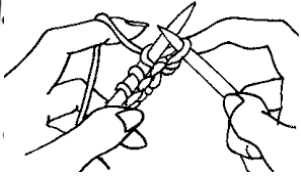

# ei-klank

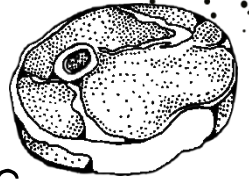

Oefen om die klank te skryf.

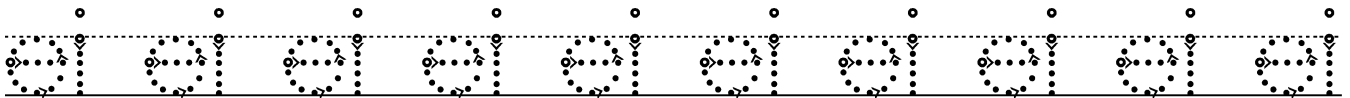
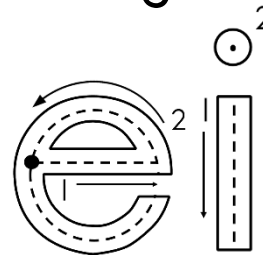
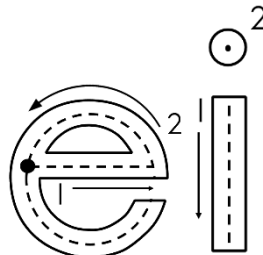
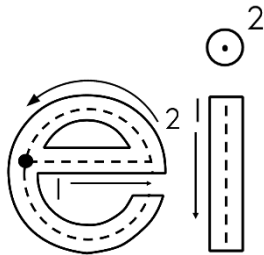

Lees die woorde. Onderstreep die ei-klank.

brei	trein	klei
meisie	klein	reis
sein	vlei	vleis
aarbei	paleis	eiland





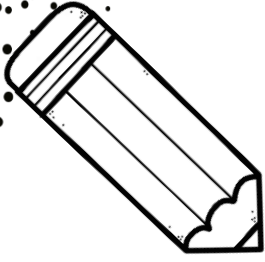



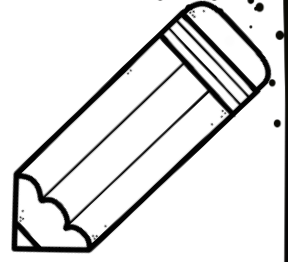



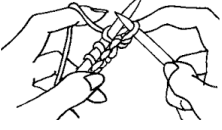
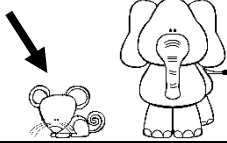
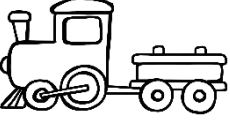

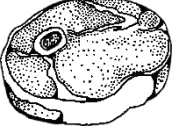
# ei-klank

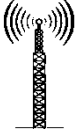

Lees en skryf die woorde.

	brei	brei	
	klein	klein	
	trein	trein	
	vlei	vlei	
	vleis	vleis	
	reis	reis	
	sein	sein	
	meisie	meisie	
	paleis	paleis	
	eiland	eiland	
	klei	klei	



# eu-klank

Oefen om die klank te skryf.

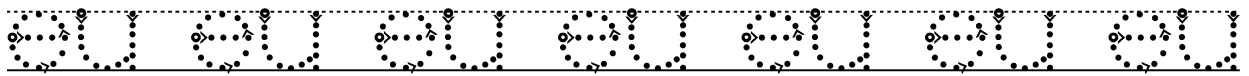
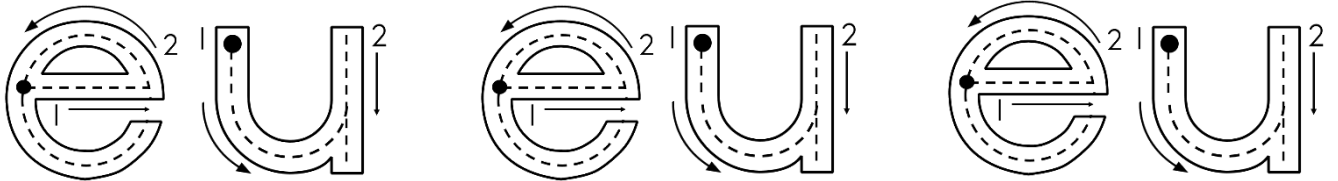

Lees die woorde. Onderstreep die eu-klank.

neus

reus

neut

jeuk

seun

leun

deur

geut

sleutel

reuk

kreun

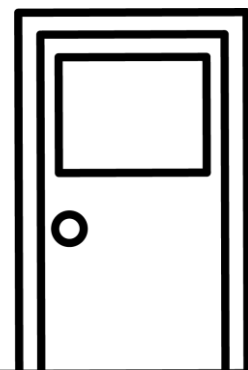

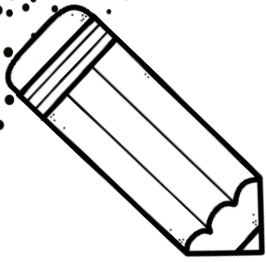



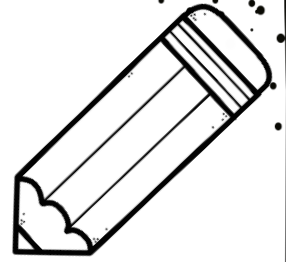



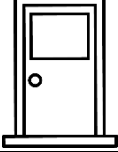

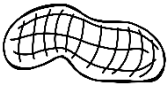

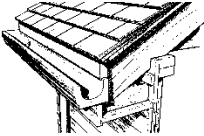
# eu-klank

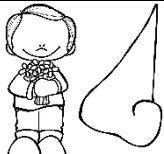

Lees en skryf die woorde.

	deur	deur	
	neus	neus	
	neut	neut	
	reus	reus	
	geut	geut	
	leun	leun	
	seun	seun	
	sleutel	sleutel	
	jeuk	jeuk	
	reuk	reuk	
	kreun	kreun	



# oe-klank

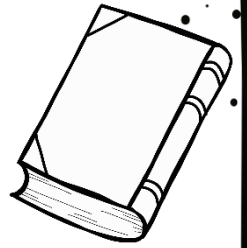

Oefen om die klank te skryf.

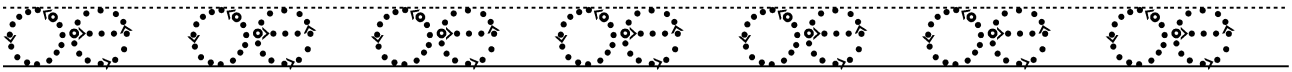
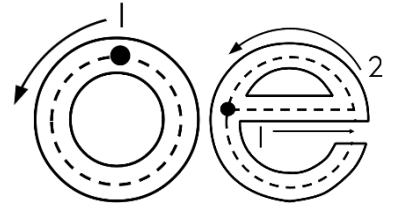
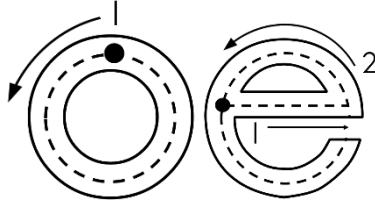
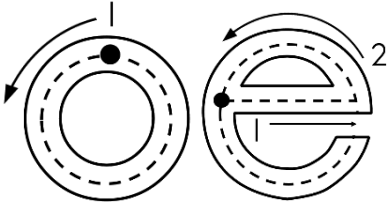

Lees die woorde. Onderstreep die oe-klank.

koek

boek

soek

doek

hoek

loer

hoed

voet

soet

moet

proe

broek

soen

voer

boer

# oe-klank

Lees en skryf die woorde.

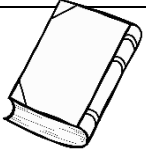

boek

boek



doek

doek



koek

koek



broek

broek



hoed

hoed



voet

voet



boer

boer



soen

soen



voer

voer



proe

proe



loer

loer



# ou-klank



Oefen om die klank te skryf.

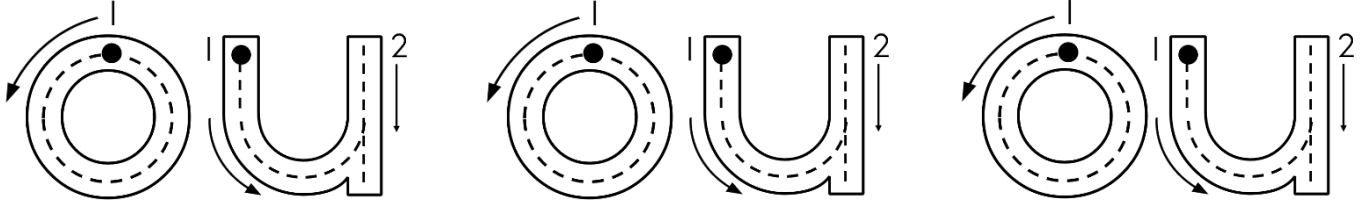

Lees die woorde. Onderstreep die ou-klank.



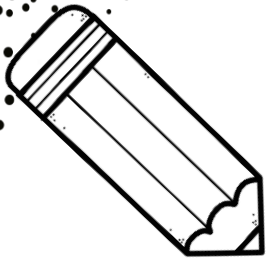



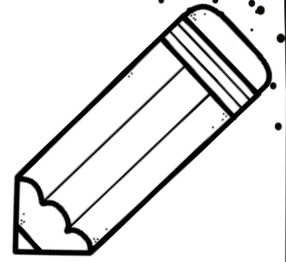

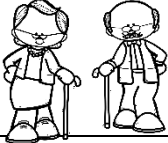

bou	oud	mou
koud	sout	sous
stout	ouma	oupa
trou	kous	hout
hou	fout	goud



# ou-klank

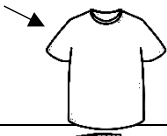

Lees en skryf die woorde.

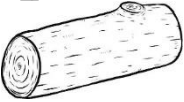
	oud	oud	
	trou	trou	
	ouma	ouma	
	oupa	oupa	
	koud	koud	
	sous	sous	
	sout	sout	
	stout	stout	
	bou	bou	
	mou	mou	
	kous	kous	
	hout	hout	

Sê die prent se naam. Luister na die middelklank en vul die regte klank in.

-oe-, -ei-, -ie-, -eu-, -ui-

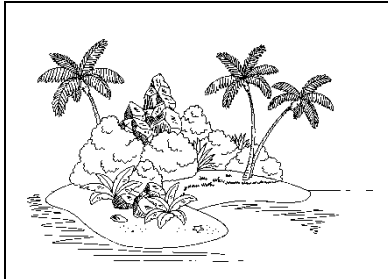

\_\_\_land

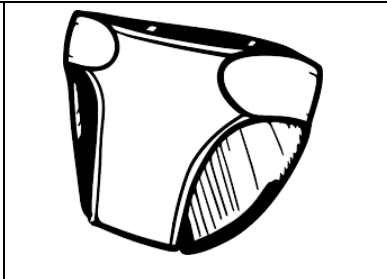

d\_\_\_k

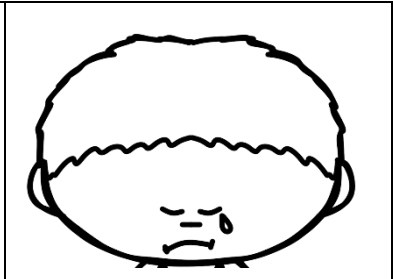

h\_\_\_l

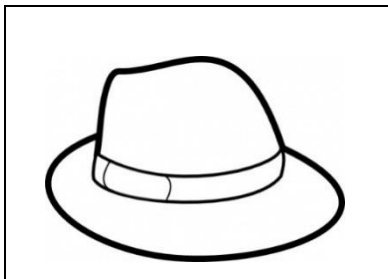

h\_\_\_d

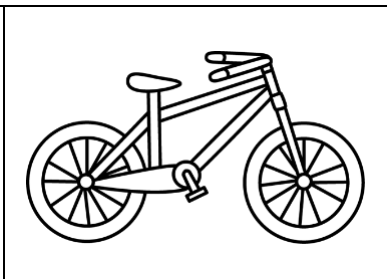

f\_\_\_ts

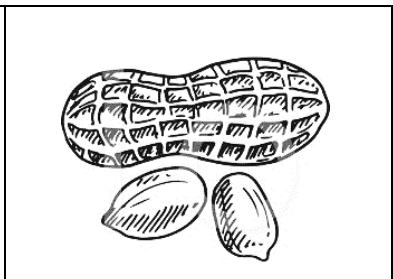

n\_\_\_t

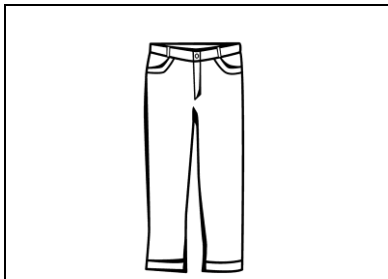

br\_\_\_k

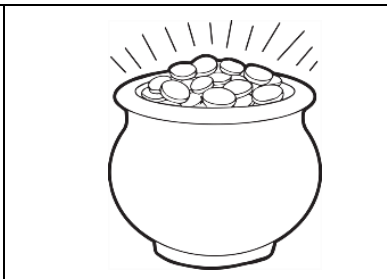

g\_\_\_d

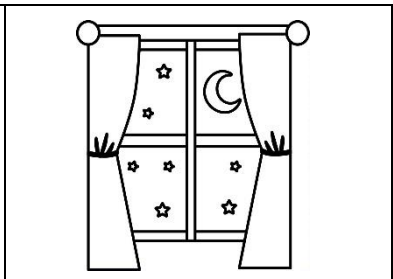

r\_\_\_t



r\_\_\_s

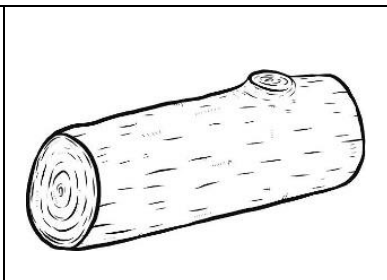

h\_\_\_t

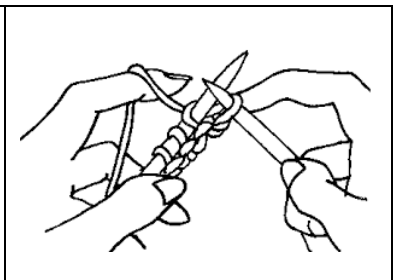

br\_\_\_



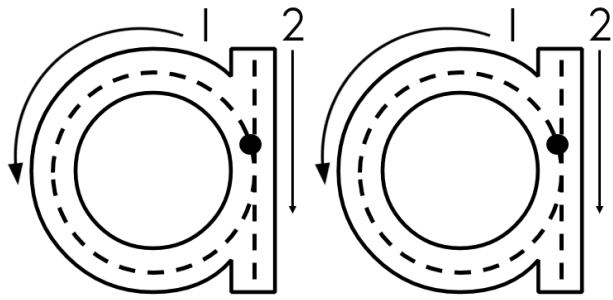

Oefen om die aa-klank te skryf.

\_\_\_\_\_

.....

\_\_\_\_\_

\_\_\_\_\_

.....

\_\_\_\_\_

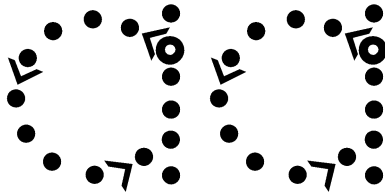

Skryf die aa-klank in die blokkies.

--	--

Vul die aa-klank in.

k _____ s	h _____ r
r _____ s	pl _____ s
s _____ m	g _____ n
_____ p	v _____ k

Lees die sinne en onderstreep die aa-woorde.

1. Ben moet kaas koop.
2. Juffrou raas met Ben.
3. Ons speel lekker saam.
4. Die aap swaai aan die tak.
5. Jana gee 'n lang gaap.
6. Dit is haar boek.

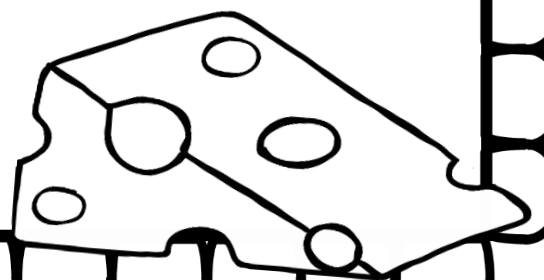



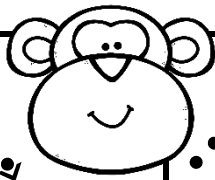

Tracing practice for the letter 'd'. It includes two solid 'd' characters with dashed outlines and numbered arrows (1 for the counter-clockwise circle, 2 for the vertical line) showing stroke order. To the right is a dotted 'd' with arrows indicating the path for tracing.

Tracing practice for the letter 'd'. It includes two solid 'd' characters with dashed outlines and numbered arrows (1 for the counter-clockwise circle, 2 for the vertical line) showing stroke order. To the right is a dotted 'd' with arrows indicating the path for tracing.

Tracing practice for the letter 'd'. It includes two solid 'd' characters with dashed outlines and numbered arrows (1 for the counter-clockwise circle, 2 for the vertical line) showing stroke order. To the right is a dotted 'd' with arrows indicating the path for tracing.

Tracing practice for the letter 'd'. It includes two solid 'd' characters with dashed outlines and numbered arrows (1 for the counter-clockwise circle, 2 for the vertical line) showing stroke order. To the right is a dotted 'd' with arrows indicating the path for tracing.

Tracing practice for the letter 'd'. It includes two solid 'd' characters with dashed outlines and numbered arrows (1 for the counter-clockwise circle, 2 for the vertical line) showing stroke order. To the right is a dotted 'd' with arrows indicating the path for tracing.

Tracing practice for the letter 'd'. It includes two solid 'd' characters with dashed outlines and numbered arrows (1 for the counter-clockwise circle, 2 for the vertical line) showing stroke order. To the right is a dotted 'd' with arrows indicating the path for tracing.

Tracing practice for the letter 'd'. It includes two solid 'd' characters with dashed outlines and numbered arrows (1 for the counter-clockwise circle, 2 for the vertical line) showing stroke order. To the right is a dotted 'd' with arrows indicating the path for tracing.

Tracing practice for the letter 'd'. It includes two solid 'd' characters with dashed outlines and numbered arrows (1 for the counter-clockwise circle, 2 for the vertical line) showing stroke order. To the right is a dotted 'd' with arrows indicating the path for tracing.

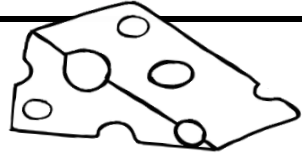

Tracing practice for the letter 'd'. It includes two solid 'd' characters with dashed outlines and numbered arrows (1 for the counter-clockwise circle, 2 for the vertical line) showing stroke order. To the right is a dotted 'd' with arrows indicating the path for tracing.

Tracing practice for the letter 'd'. It includes two solid 'd' characters with dashed outlines and numbered arrows (1 for the counter-clockwise circle, 2 for the vertical line) showing stroke order. To the right is a dotted 'd' with arrows indicating the path for tracing.

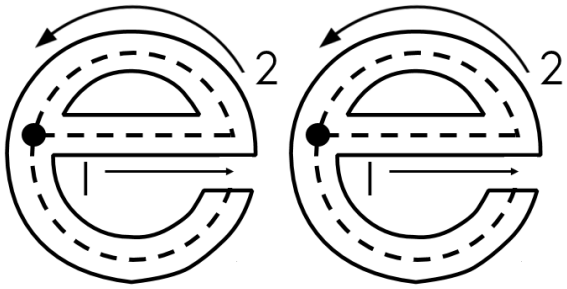

Oefen om die ee-klank te skryf.

\_\_\_\_\_

-----

\_\_\_\_\_

-----

\_\_\_\_\_

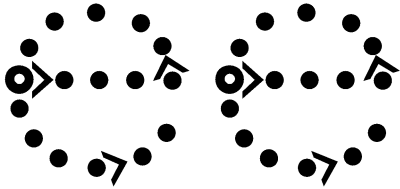

Skryf die ee-klank in die blokkies.

--	--

Vul die ee-klank in.

g _____ l	g _____
v _____ r	_____ nd
s _____ r	sp _____ l
m _____ l	b _____ r

Lees die sinne en onderstreep die ee-woorde.

1. Sy dra 'n geel pet.
2. Ek speel met my beer.
3. Daar is baie eende by die dam.
4. Die eend se veer is grys.
5. Ek wil weer see toe gaan.
6. Karel is eerste in die water.
7. Mamma bak brood met meel.
8. My voet is seer.



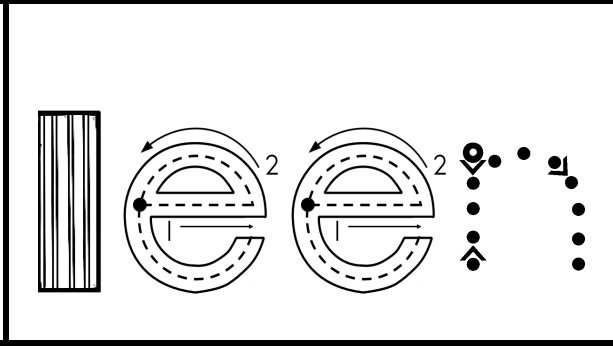
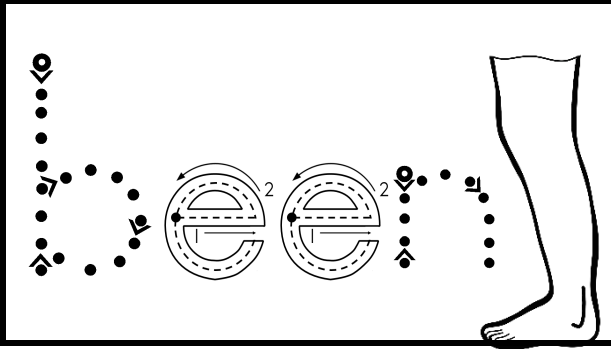
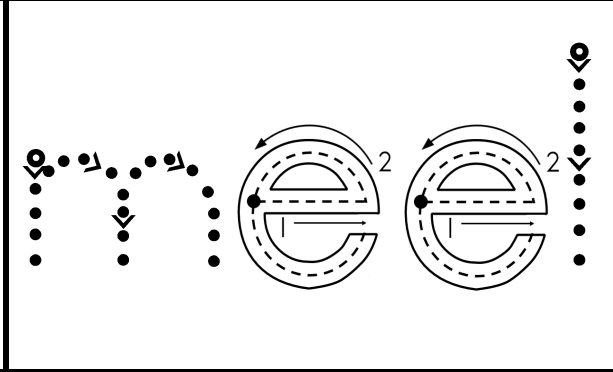
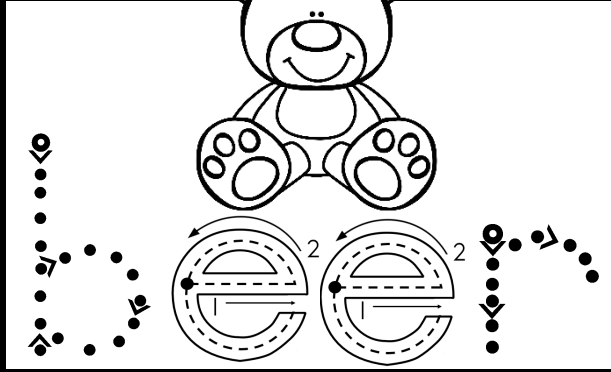
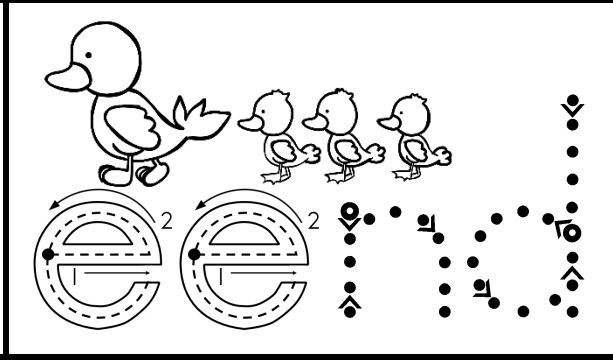
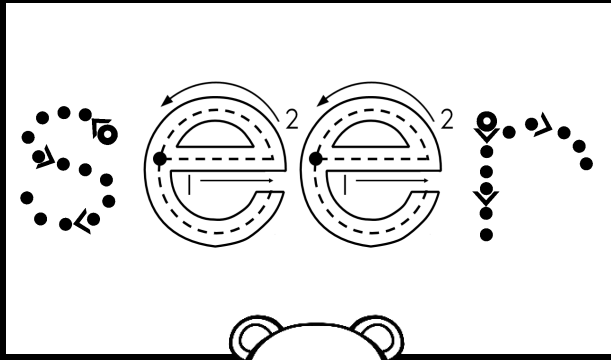
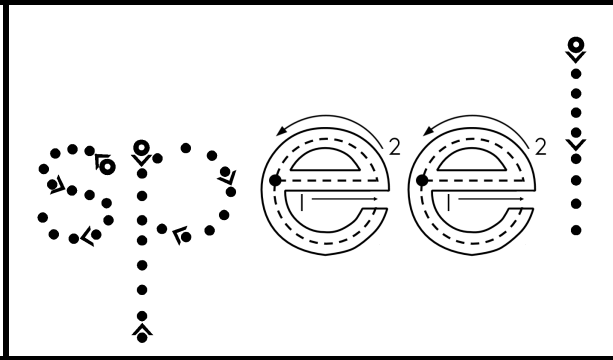
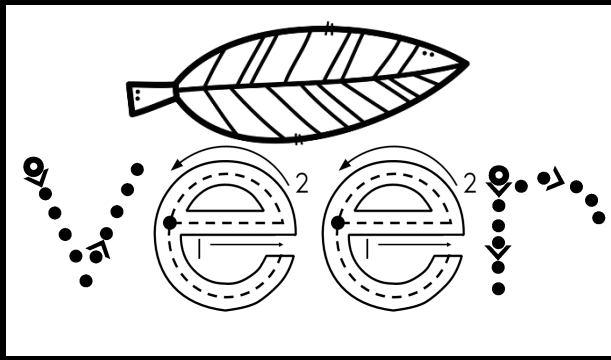
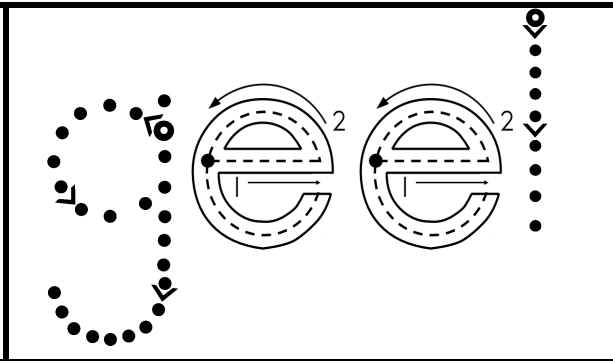
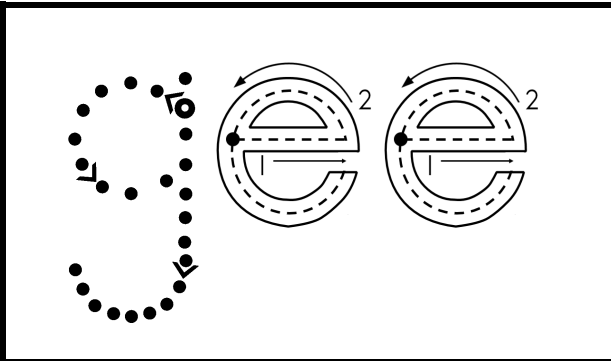

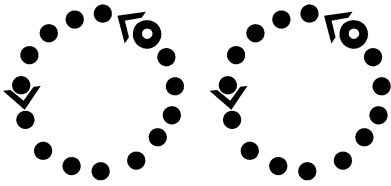
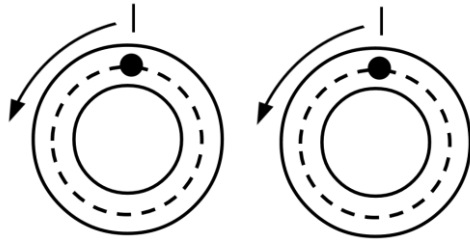

Oefen om die oo-klank te skryf.

---

---

---

---

---

---

Skryf die oo-klank in die blokkies.

--	--

Vul die oo-klank in.

l \_\_\_\_ p      t \_\_\_\_ n

k \_\_\_\_ p      p \_\_\_\_ t

r \_\_\_\_ s      b \_\_\_\_ n

b \_\_\_\_ m      r \_\_\_\_ k

Lees die sinne en onderstreep die oo-woorde.

1. Karla koop 'n rok.
2. Die roos is rooi.
3. Ek loop na my maat.
4. Danie stamp sy toon.
5. Die boom het appels.
6. Die hond lek sy poot.
7. Die vuur maak rook.
8. Die boer plant 'n boon.
9. "Mamma" was my eerste woord.

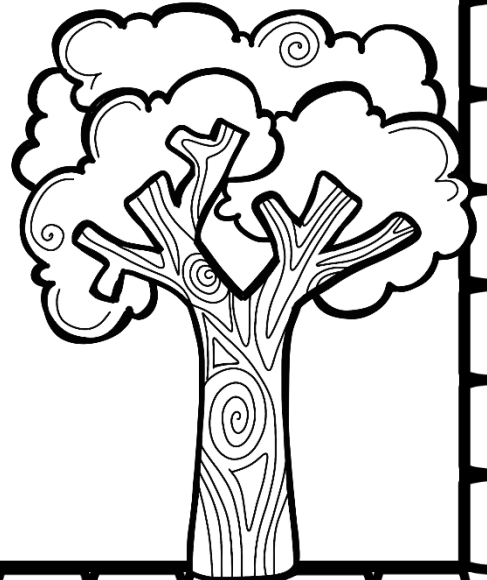

Tracing practice for the letter 'C'.

Tracing practice for the letter 'C' with a cartoon girl illustration.

Tracing practice for the letter 'C' with a rose illustration.

Tracing practice for the letter 'C' with a tree illustration.

Tracing practice for the letter 'C' with a hand pointing to the letter.

Tracing practice for the letter 'C' with a cross illustration.

Tracing practice for the letter 'C' with a kidney bean illustration.

Tracing practice for the letter 'C' with a cartoon boy illustration.

Tracing practice for the letter 'C' with multiple dotted 'C's.

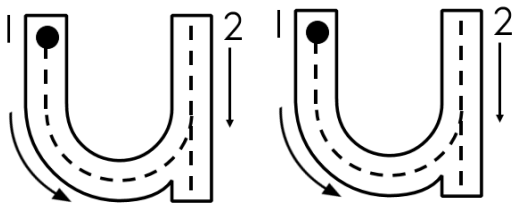

Oefen om die uu-klank te skryf.

---

---

---

---

---

---

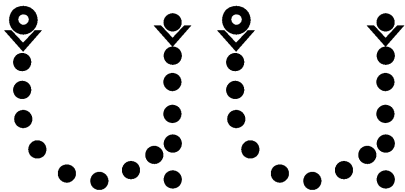

Skryf die uu-klank in die blokkies.

--	--

Vul die uu-klank in.

v \_\_\_\_ r

h \_\_\_\_ r

d \_\_\_\_ r

m \_\_\_\_ r

s \_\_\_\_ r

Lees die sinne en onderstreep die uu-woorde.

1. Die vuur is warm.
2. Die suurlemon is suur.
3. Die rok is duur.
4. Ons gaan die huis huur.
5. My pa bou 'n groot muur.



Skryf die woord.

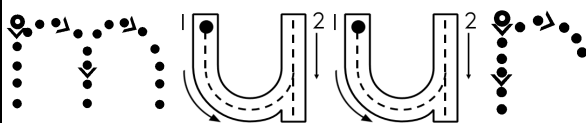
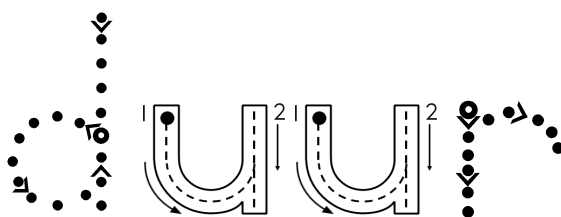
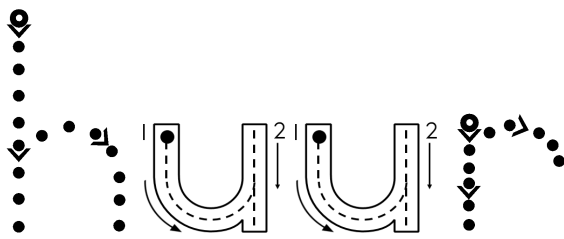
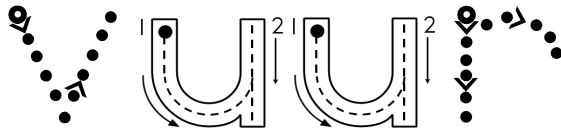
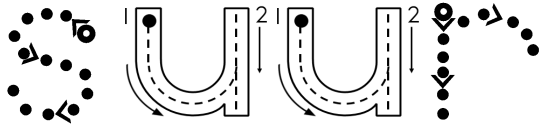

Sê die prent se naam. Luister na die klank en vul die regte klank in.

aa, ee, oo, uu

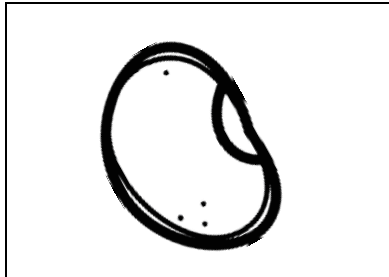

b\_\_n

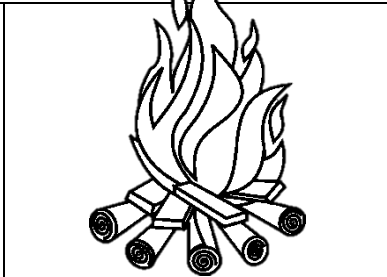

v\_\_r

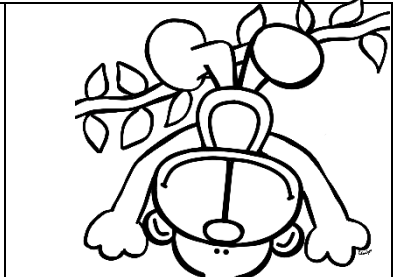

\_\_p

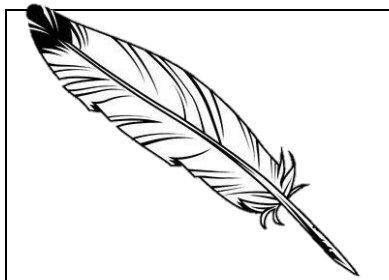

v\_\_r

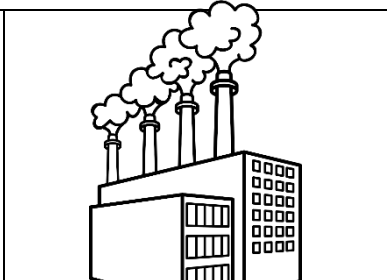

r\_\_k

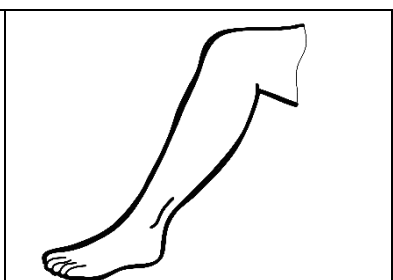

b\_\_n

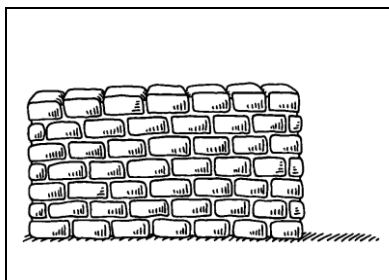

m\_\_r

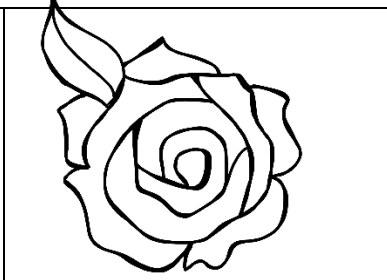

r\_\_s

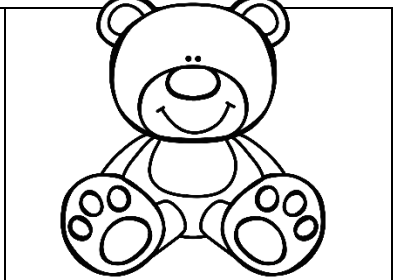

b\_\_r

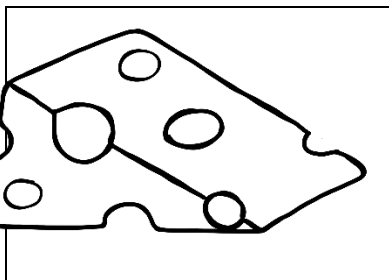

k\_\_s

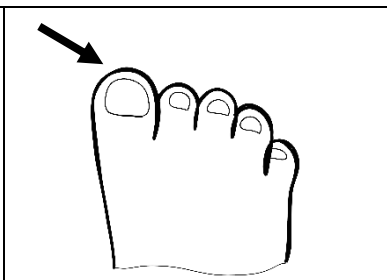

t\_\_n

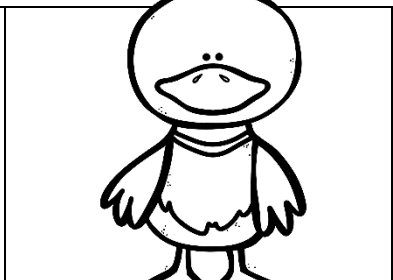

\_\_nd



Kleur die "pr-klank" in.

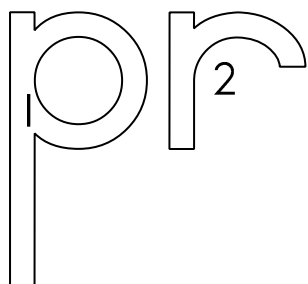

1 - groen  
2 - geel

Lees die woorde.

pruim	praat	preek
prys	pruik	proe
prop	pret	prag

Trek oor die klank.

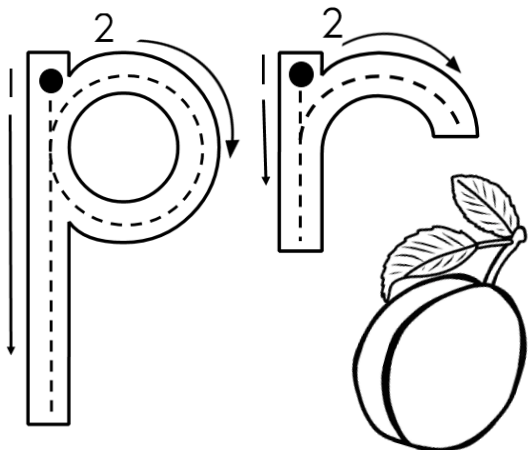

Omkring al die pr-klanke.

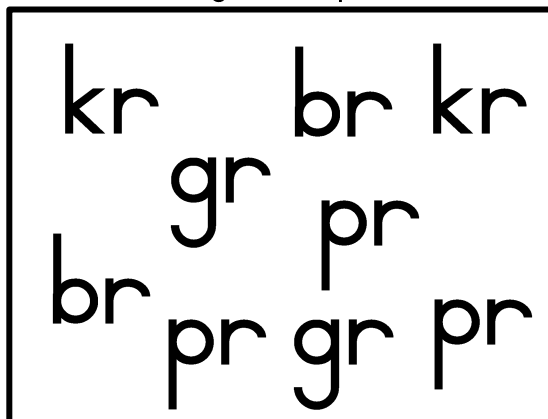

Soek die pr-woorde en kleur dit in.

h	p	t	p	r	e	e	k	l	r
d	r	a	c	l	o	a	s	a	p
m	o	l	p	r	y	s	n	y	r
a	e	a	k	n	a	c	a	u	a
t	e	y	e	b	k	p	k	l	a
g	p	r	u	i	m	a	e	o	t
h	a	t	e	d	d	y	b	k	i
c	a	p	r	u	i	k	k	e	n

preek
proe
praat
pruik
pruim
prys

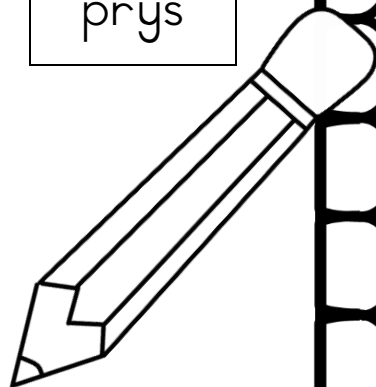



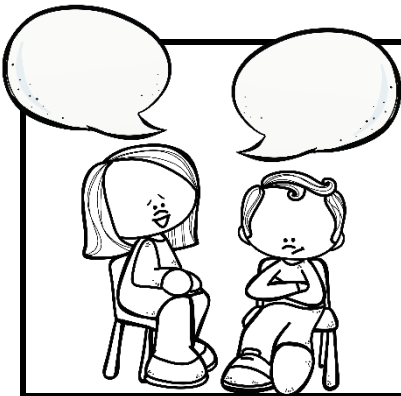
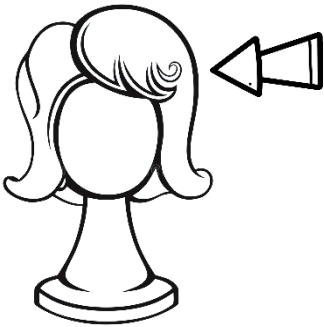
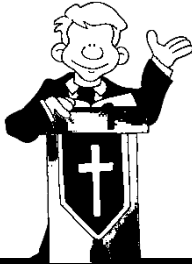

# pr-klank

Skryf die woord vir elke prent en onderstreep die pr-klank.

	Mamma kyk eers wat is die _____ van die rok.	

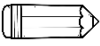
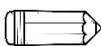
		Die dominee _____ vir ons Sondag.
		

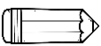
Bou die pr-woorde.

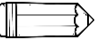
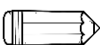
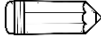
 pr	ys	<input type="text"/>	 pr	et	<input type="text"/>
 pr	eek	<input type="text"/>	 pr	uim	<input type="text"/>
 pr	aat	<input type="text"/>	 pr	uik	<input type="text"/>
 pr	oe	<input type="text"/>	 pr	op	<input type="text"/>

Kleur die "gr-klank" in.



1 - groen  
2 - pers

Lees die woorde.

grap	grys	gryp	gras
groot	graan	graag	grot
graaf	graat	grond	grou

Trek oor die klank.

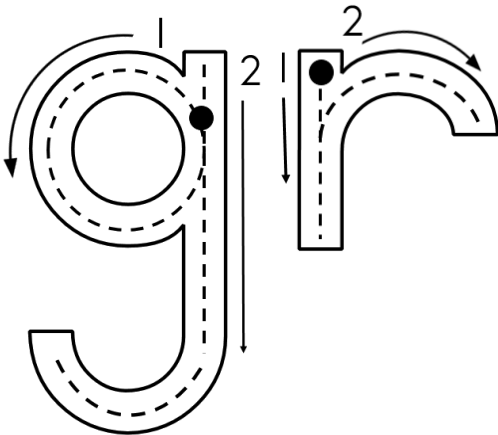

Omkring al die gr-klanke.

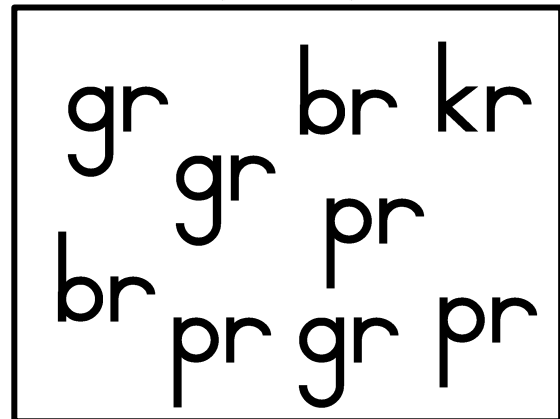

Soek die gr-woorde en kleur dit in.

g	r	o	n	d	g	e	k	l	r
d	r	a	c	l	o	a	s	g	p
g	o	g	r	a	s	s	g	r	r
r	e	a	k	n	a	c	r	o	g
y	e	y	e	b	k	p	a	o	r
s	p	r	u	i	m	a	a	t	y
h	a	t	e	d	d	y	n	k	p
c	a	p	r	u	i	k	k	e	n

grys
groot
graan
gryp
gras
grond

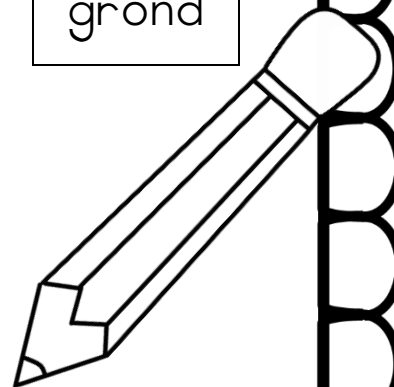





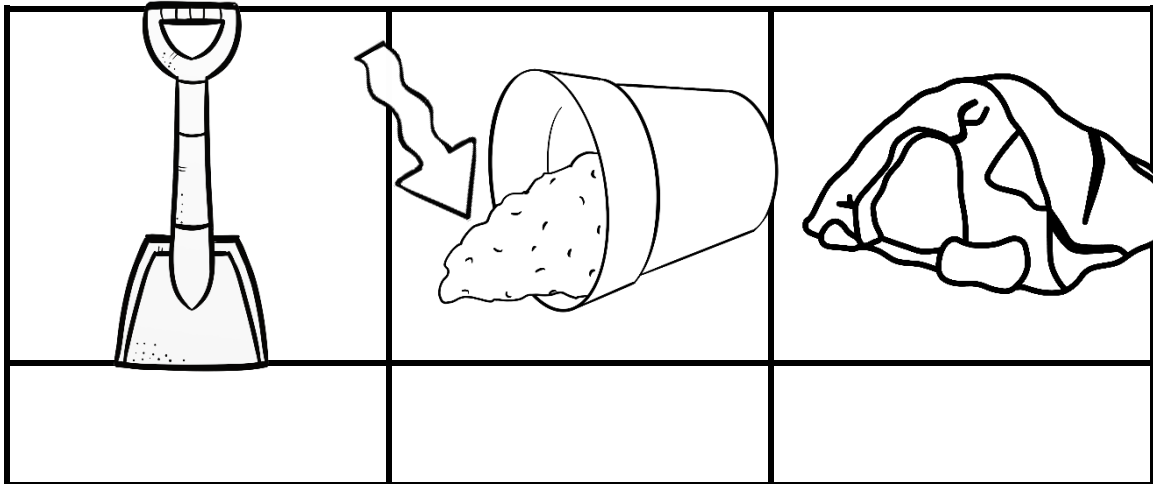
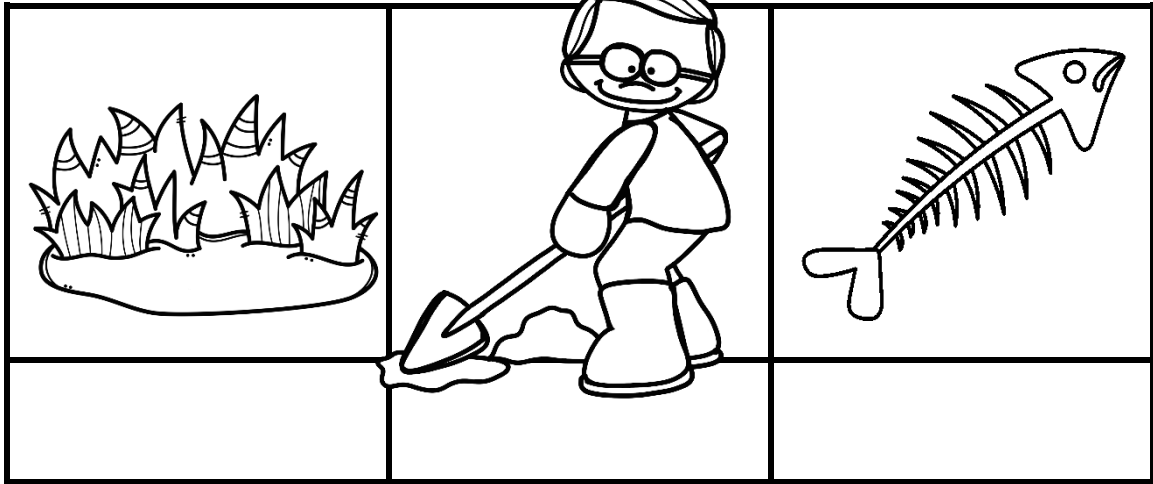



# gr-klank

Skryf die woord vir elke prent en onderstreep die gr-klank.



Bou die gr-woorde.

 gr	ys	<input type="text"/>	 gr	ond	<input type="text"/>
 gr	as	<input type="text"/>	 gr	yp	<input type="text"/>
 gr	aat	<input type="text"/>	 gr	ap	<input type="text"/>
 gr	oen	<input type="text"/>	 gr	aaf	<input type="text"/>

Kleur die "kr-klank" in.

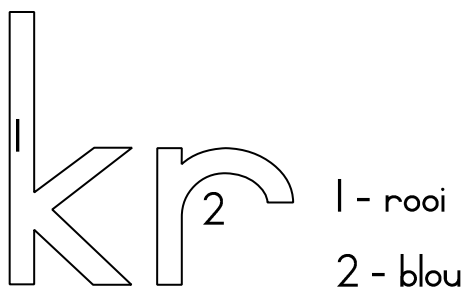

Lees die woorde.

krap	kriek	kraai
kraak	kruis	kreun
kry	kraan	krom

Trek oor die klank.

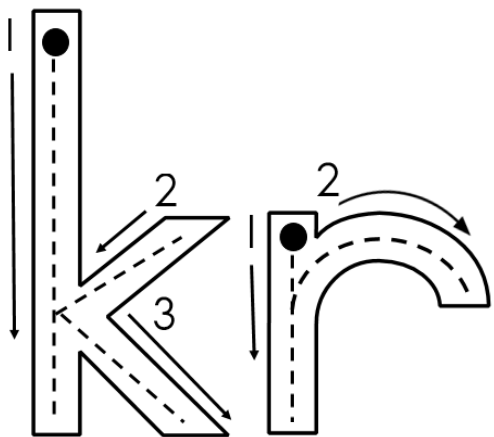

Omkring al die kr-klanke.

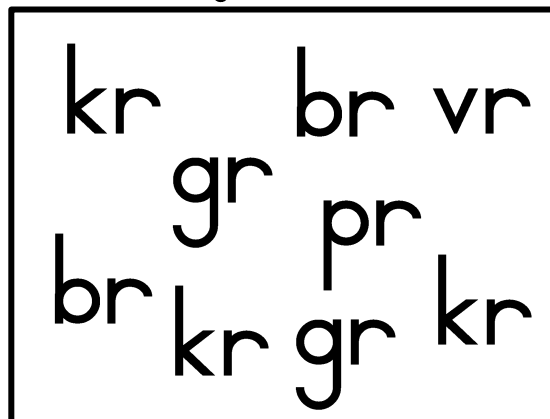

Soek die kr-woorde en kleur dit in.

k	r	o	u	r	k	r	a	a	i
r	r	a	c	l	o	a	s	v	r
e	o	l	p	r	y	s	k	r	k
u	k	r	a	a	k	c	r	a	r
n	e	v	e	b	k	p	a	a	i
g	p	r	u	i	m	a	p	g	e
k	r	u	i	s	d	y	b	k	k
c	a	t	r	v	r	u	g	e	n

krap
kriek
kruis
kraak
kreun
kraai

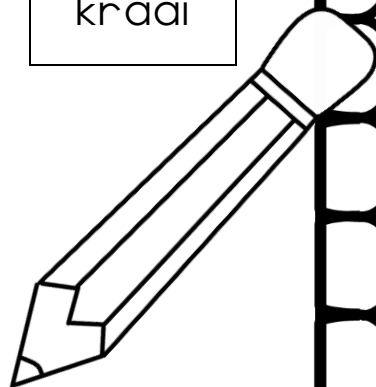





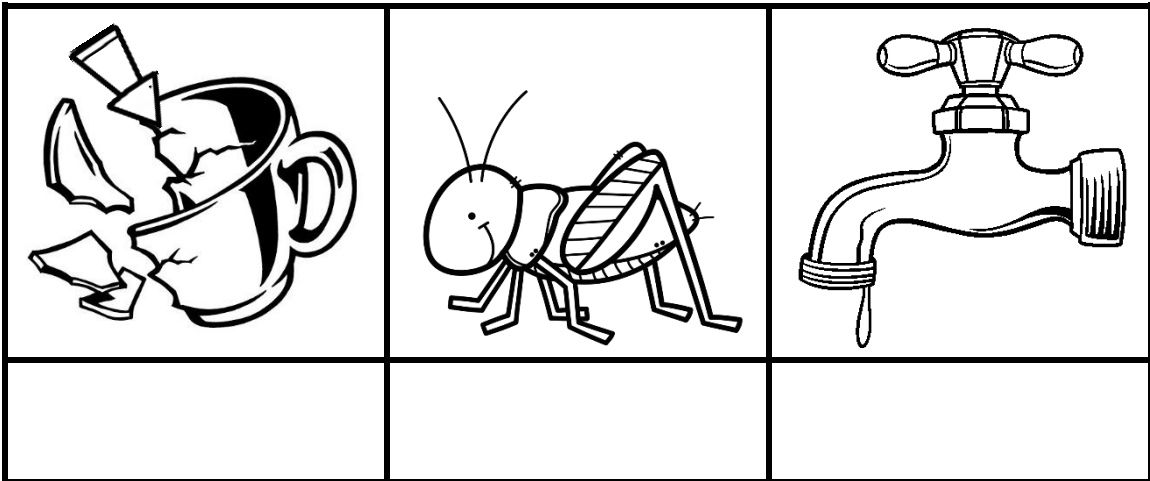
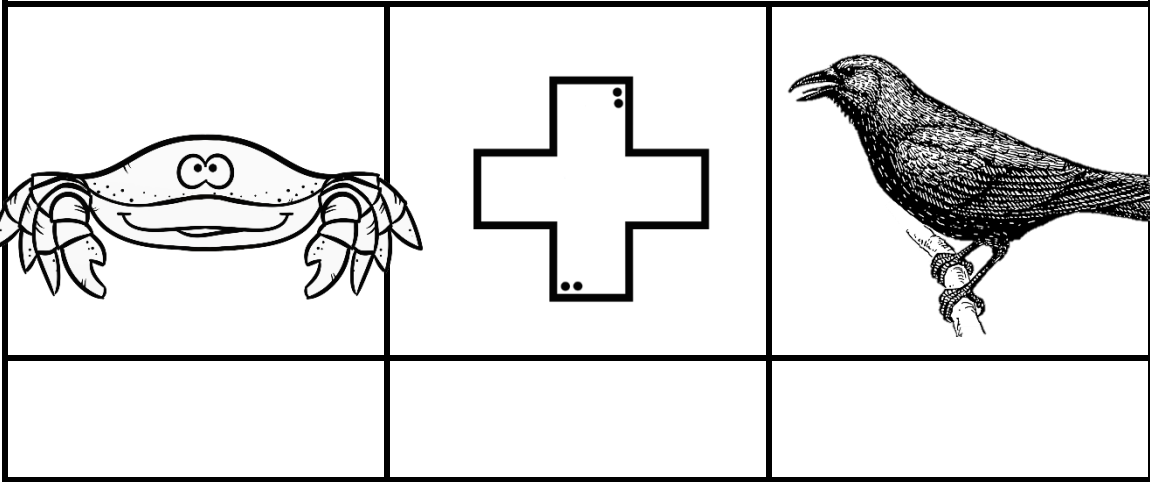



# kr-klank

Skryf die woord vir elke prent en onderstreep die kr-klank.



Bou die kr-woorde.

 kr	eun	<input type="text"/>	 kr	aak	<input type="text"/>
 kr	aai	<input type="text"/>	 kr	uis	<input type="text"/>
 kr	ap	<input type="text"/>	 kr	om	<input type="text"/>
 kr	iek	<input type="text"/>	 kr	aan	<input type="text"/>

Kleur die "tr-klank" in.

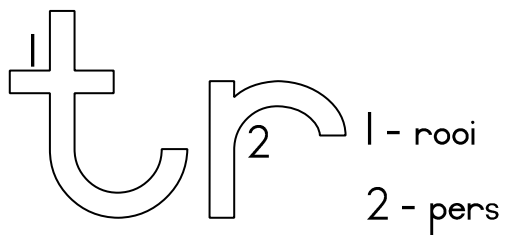

Lees die woorde.

trein	trek	troon
traan	treur	trui
trou	tref	trap

Trek oor die klank.

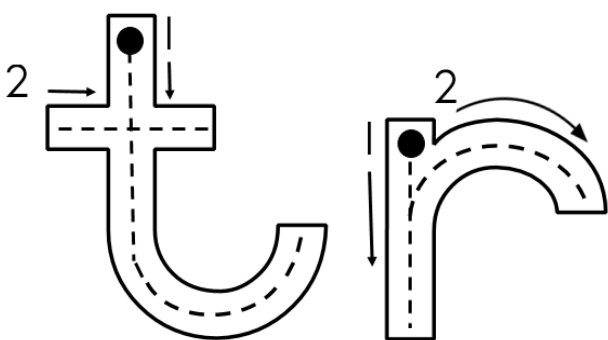

Omkring al die tr-klanke.

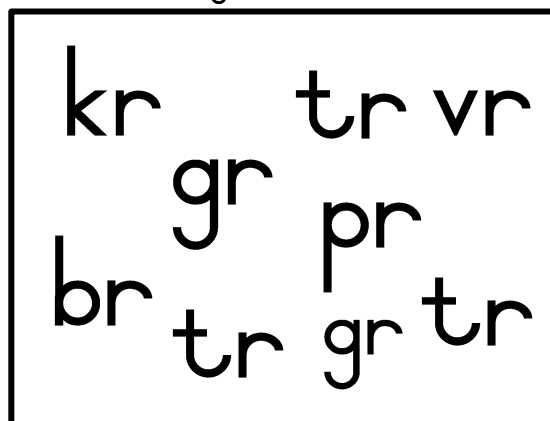

Soek die tr-woorde en kleur dit in.

t	r	t	r	e	u	r	a	a	i
r	r	a	c	l	o	a	s	v	r
a	o	l	t	r	y	s	t	r	k
a	k	r	r	a	k	c	r	a	t
n	e	v	e	b	k	p	u	a	r
g	p	r	k	i	m	a	i	g	e
k	r	u	i	s	d	y	b	k	i
t	r	o	o	n	r	u	g	e	n

trein
trui
troon
traan
treur
trek

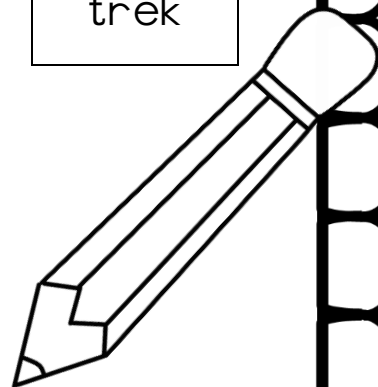







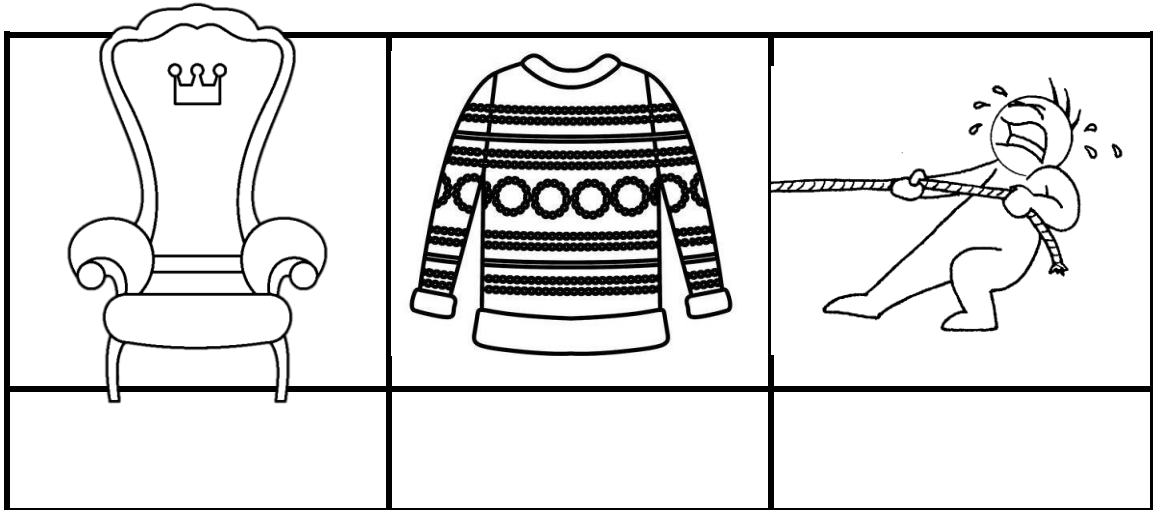
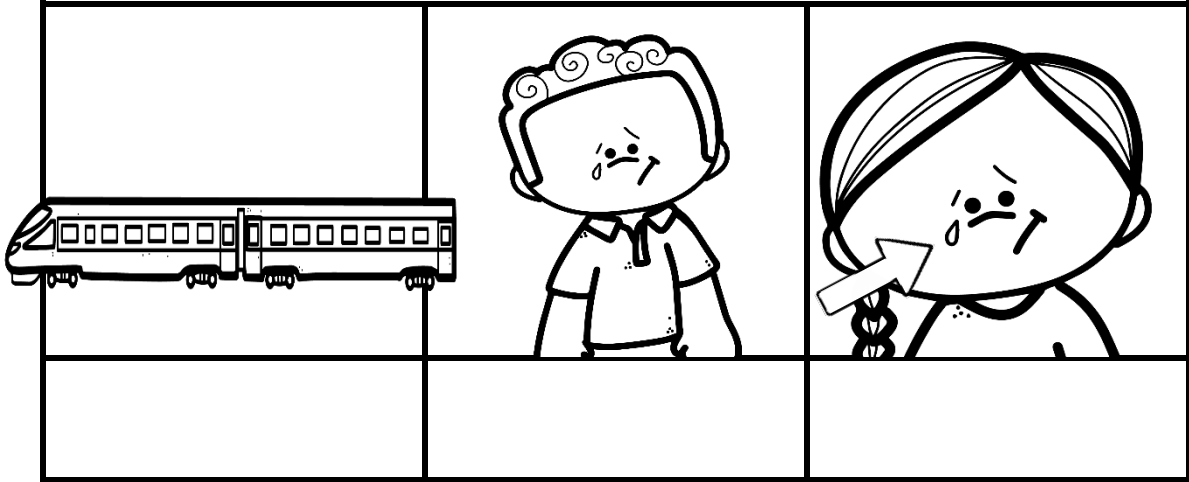

# tr-klank

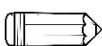
Skryf die woord vir elke prent en onderstreep die tr-klank.

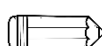
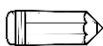

Bou die tr-woorde.

 tr	aan	<input type="text"/>	 tr	ein	<input type="text"/>
 tr	eur	<input type="text"/>	 tr	oon	<input type="text"/>
 tr	ui	<input type="text"/>	 tr	ef	<input type="text"/>
 tr	ek	<input type="text"/>	 tr	ou	<input type="text"/>



Kleur die "dr-klank" in.

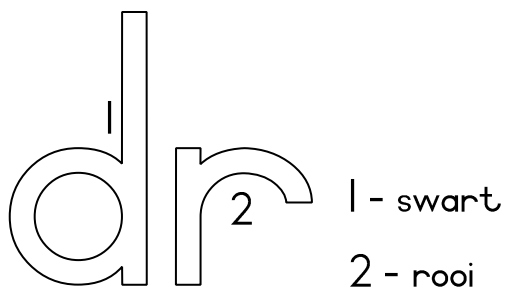

Lees die woorde.

dra	druk	draai
dryf	draf	drag
droom	drie	draak

Trek oor die klank.

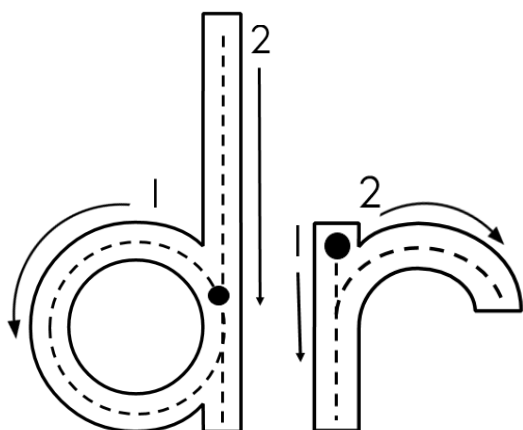

Omkring al die dr-klanke.

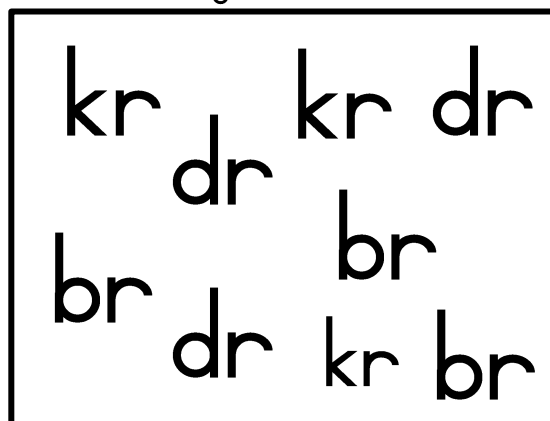

Soek die dr-woorde en kleur dit in.

t	r	t	d	r	y	f	a	a	d
r	d	d	c	l	o	a	s	v	r
a	r	r	t	r	y	s	t	r	u
a	a	a	r	a	d	r	a	a	k
n	f	g	e	b	k	p	u	a	r
g	p	r	k	i	m	a	i	g	e
k	r	d	r	a	a	i	b	k	i
t	r	o	o	n	r	u	g	e	n

draaf
drag
dryf
draai
druk
dra

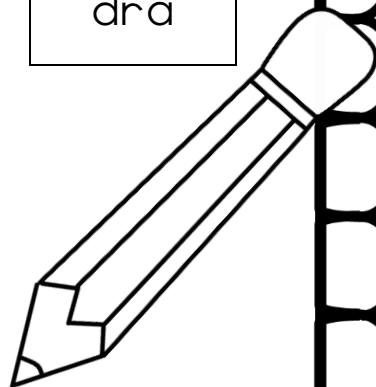





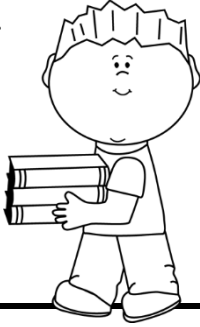
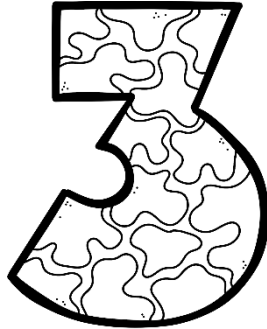

# dr-klank

Skryf die woord vir elke prent en onderstreep die dr-klank.

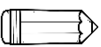
	Die seun _____ die boeke.		

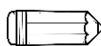
	My pa gee my 'n stywe _____.		Die seun sit en dag _____ in die klas.
			

Bou die dr-woorde.

 dr	—	ag	—	<input type="text"/>	 dr	—	a	—	<input type="text"/>
 dr	—	aai	—	<input type="text"/>	 dr	—	af	—	<input type="text"/>
 dr	—	yf	—	<input type="text"/>	 dr	—	ie	—	<input type="text"/>
 dr	—	uk	—	<input type="text"/>	 dr	—	oom	—	<input type="text"/>

Kleur die spr-klank in.

1 - 2 - 3  
s p r

1 - blou

2 - groen

3 - geel

- Lees die woorde.
- Kleur die spr-klank in.

spraak

sproei

spreeu

spring

spruit

sproet

spreek

spruit

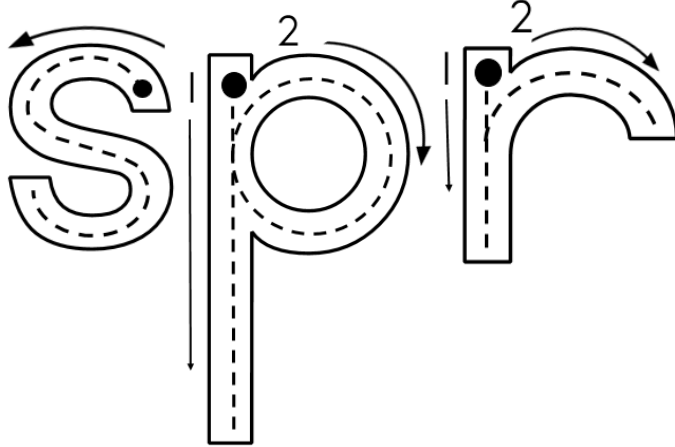

Kyk of jy die klanke kan saamvoeg om woorde te bou.

oei → [ ] [ ] [ ] [ ] [ ] [ ] [ ] [ ]

eeu → [ ] [ ] [ ] [ ] [ ] [ ] [ ] [ ]

ing → [ ] [ ] [ ] [ ] [ ] [ ] [ ] [ ]

oet → [ ] [ ] [ ] [ ] [ ] [ ] [ ] [ ]

Kleur die str-klank in.

1 - blau

2 - groen

3 - geel

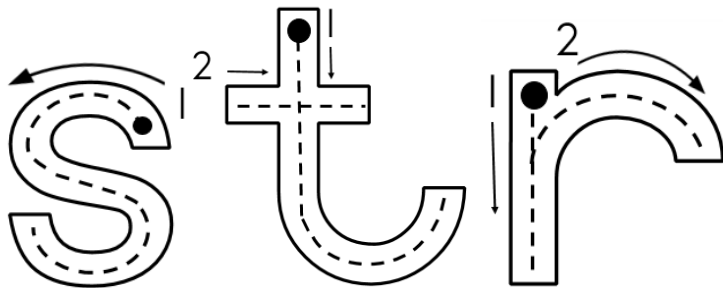
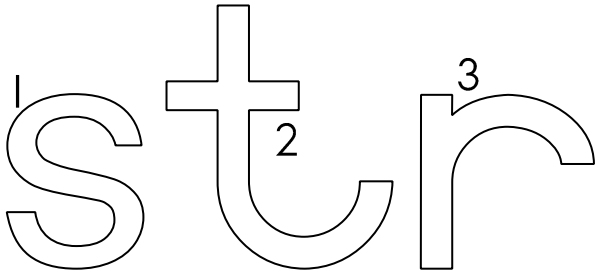

- Lees die woorde.
- Kleur die str-klank in.

straf	streef
stroom	streek
strooi	struik
stram	strik
struikel	straat

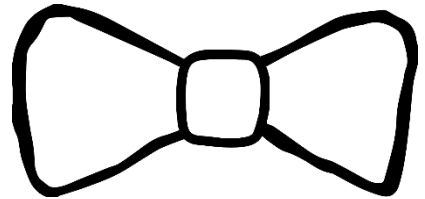

Kyk of jy die klanke kan saamvoeg om woorde te bou.

ooi → 

--	--	--	--	--

ik → 

--	--	--	--	--

am → 

--	--	--	--	--

uik → 

--	--	--	--	--

Kleur die skr-klank in.

1 - 2 - 3  
s k r

1 - geel

2 - pers

3 - pienk

• Lees die woorde.

• Kleur die skr-klank in.

skraal	skree
skrik	skroei
skrop	skraal
skroef	skraps
skreeu	skryf

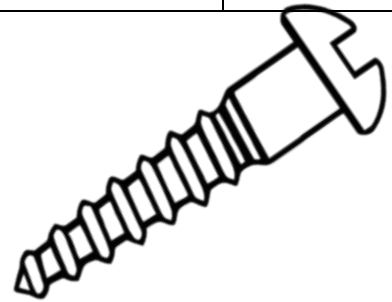
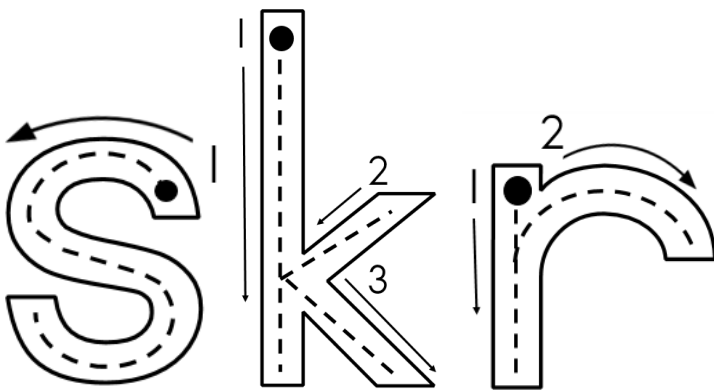

Kyk of jy die klanke kan saamvoeg om woorde te bou.

aal →

oef →

yf →

ee →

<input type="text"/>	<input type="text"/>	<input type="text"/>	<input type="text"/>	<input type="text"/>
<input type="text"/>	<input type="text"/>	<input type="text"/>	<input type="text"/>	<input type="text"/>
<input type="text"/>	<input type="text"/>	<input type="text"/>	<input type="text"/>	<input type="text"/>
<input type="text"/>	<input type="text"/>	<input type="text"/>	<input type="text"/>	<input type="text"/>

Kleur die "sk-klank" in.

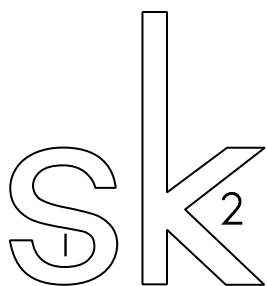

1 - oranje  
2 - geel

Lees die woorde.

skaal	skil	skoen
skool	skop	skip
skoon	skêr	skep

Trek oor die klank.

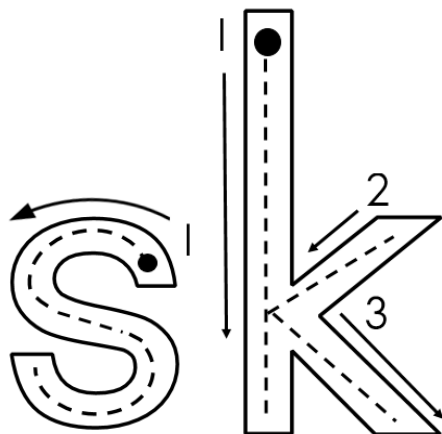

Omkring al die sk-klanke.

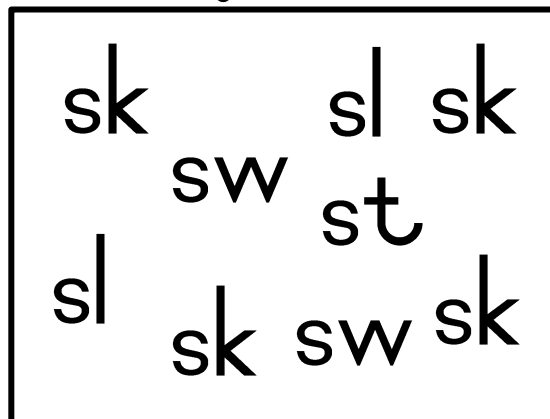

Soek die sk-woorde en kleur dit in.

k	r	o	u	r	k	s	a	a	i
r	s	k	o	o	l	k	s	v	r
e	o	l	p	r	y	a	k	r	k
u	s	k	i	p	k	a	o	a	r
n	e	v	e	b	k	l	e	a	i
g	p	r	u	i	m	a	n	g	e
s	k	o	p	s	d	y	b	k	k
c	a	t	s	k	i	p	g	e	n

skaal
skool
skoen
skop
skil
skip

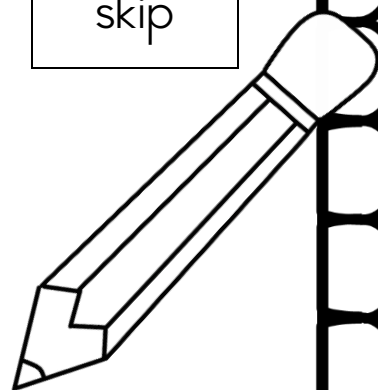

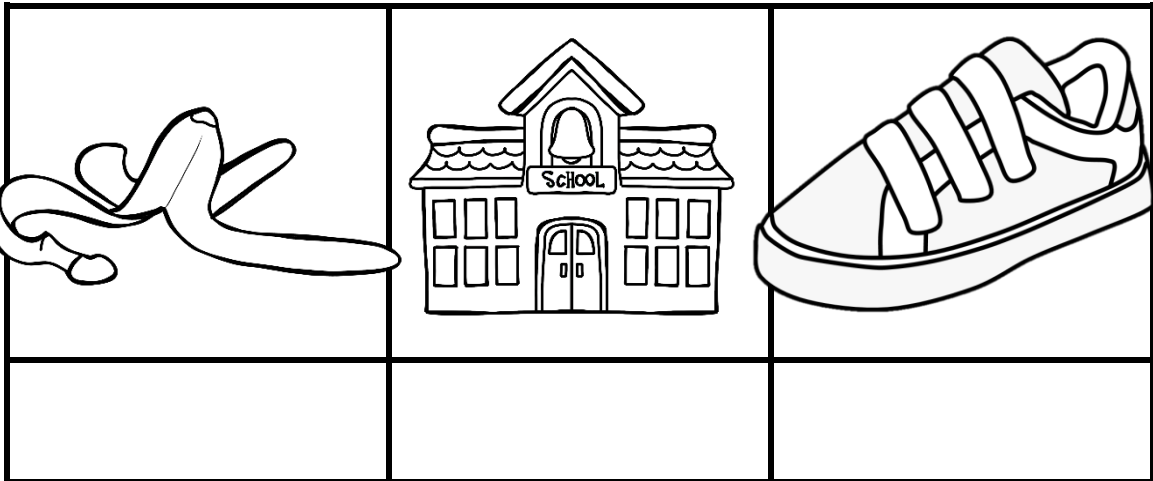
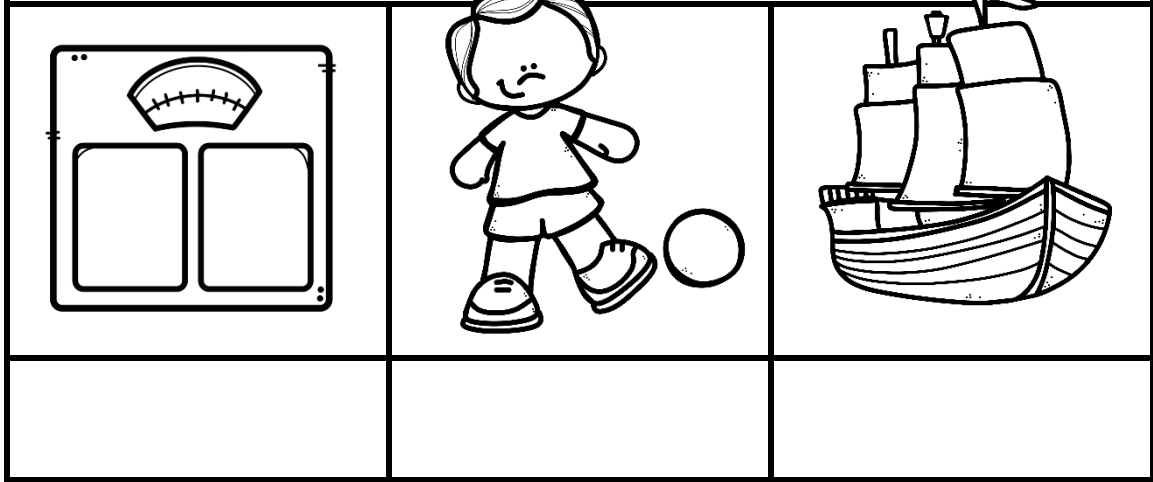

# sk-klank

Skryf die woord vir elke prent en onderstreep die sk-klank.

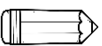
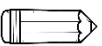
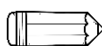
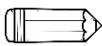
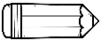

Bou die sk-woorde.

 sk	—	op	—	<input type="text"/>	 sk	—	ip	—	<input type="text"/>
 sk	—	il	—	<input type="text"/>	 sk	—	oen	—	<input type="text"/>
 sk	—	aal	—	<input type="text"/>	 sk	—	êr	—	<input type="text"/>
 sk	—	ool	—	<input type="text"/>	 sk	—	oon	—	<input type="text"/>

Kleur die "sn-klank" in.

Sn

1 - oran je

2 - rooi

Lees die woorde.

snaaks	snik	snak
snork	sny	snor
sneeu	snoet	snel

Trek oor die klank.

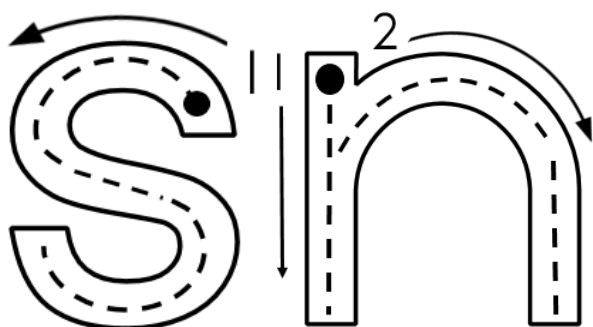

Omkring al die sn-klanke.

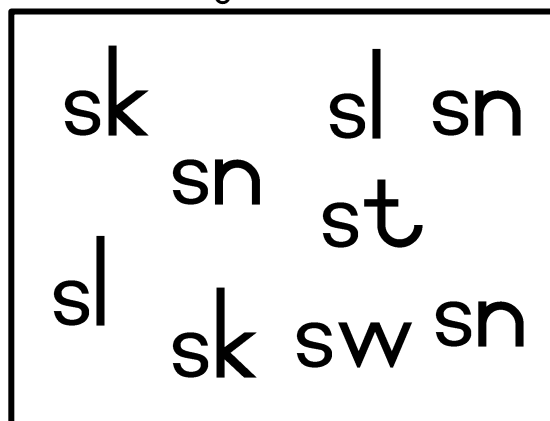

Soek die sn-woorde en kleur dit in.

s	n	a	a	k	s	s	a	a	i
s	n	o	r	k	o	a	s	v	s
e	o	l	p	r	y	s	k	r	n
s	k	r	a	a	k	c	r	a	i
n	e	v	e	b	k	p	a	a	k
a	p	r	s	n	o	r	p	g	n
k	r	u	i	s	d	y	b	k	k
c	s	n	e	l	r	u	g	e	n

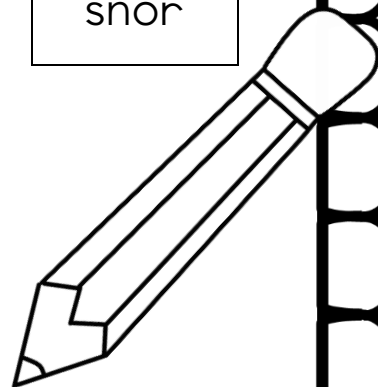

snik
snaaks
snork
snak
snel
snor









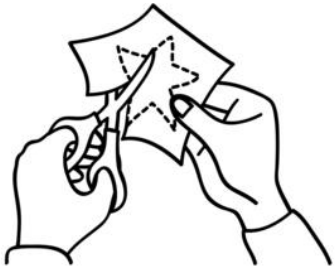

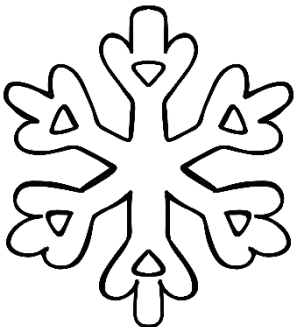
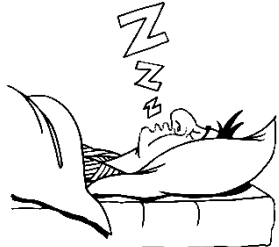



# sn-klank

Skryf die woord vir elke prent en onderstreep die sn-klank.

	<p>Die eend dink die grappie is baie _____.</p> 	
<input type="text"/>	<input type="text"/>	<input type="text"/>

	<p>Die man _____ baie hard.</p> 	<p>Die eendjie _____ soos hy huil.</p> 
<input type="text"/>	<input type="text"/>	<input type="text"/>

Bou die sn-woorde.

 sn	—	ak	—	<input type="text"/>	 sn	—	or	—	<input type="text"/>
 sn	—	ik	—	<input type="text"/>	 sn	—	y	—	<input type="text"/>
 sn	—	aaks	—	<input type="text"/>	 sn	—	eeu	—	<input type="text"/>
 sn	—	ork	—	<input type="text"/>	 sn	—	el	—	<input type="text"/>

Kleur die "sl-klank" in.

1 - pienk  
2 - pers

Lees die woorde.

slaag	slag	sleg
slaap	slak	slaan
slim	slang	sluit

Trek oor die klank.

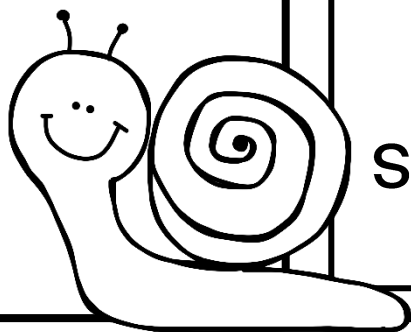

Omkring al die sl-klanke.

sk sl sk  
sw st  
sl sk sl sk

Soek die sl-woorde en kleur dit in.

s	r	o	u	r	k	r	a	a	i
l	r	a	c	l	o	a	s	v	r
a	o	l	s	l	a	k	k	r	s
a	k	r	a	a	k	c	r	a	l
p	e	v	s	l	a	g	a	a	e
s	l	a	a	g	m	a	p	g	g
k	r	u	i	s	d	y	b	k	k
c	a	t	r	s	l	a	a	n	s

slaag
slaap
slag
slak
sleg
slaan

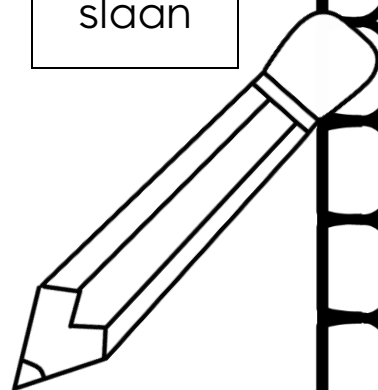

# sl-klank

Skryf die woord vir elke prent en onderstreep die sl-klank.

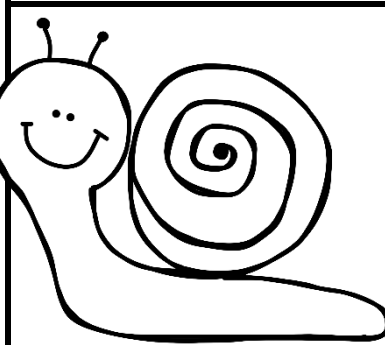

Hulle \_\_\_\_\_ die deur vir die vreemdeling.

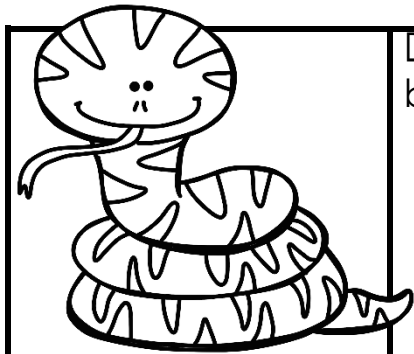
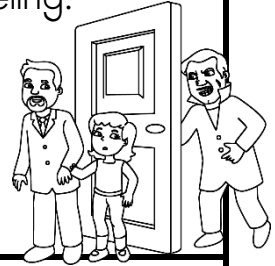

Die man \_\_\_\_\_ die bal.



Die seun is baie \_\_\_\_\_.



Bou die sl-woorde.

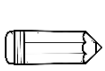

sl

aag



sl

im



sl

ak

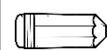

sl

ag



sl

eg

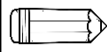

sl

uit



sl

aap

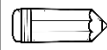

sl

aan

Kleur die "sw-klank" in.

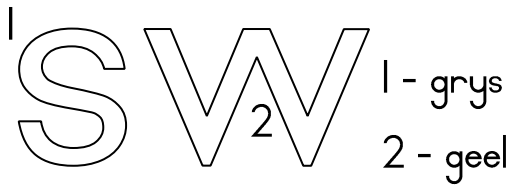

Lees die woorde.

swik	swem	swaai
sweer	swel	sweep
swaan	swoeg	swaar
sweet	swart	swak

Trek oor die klank.

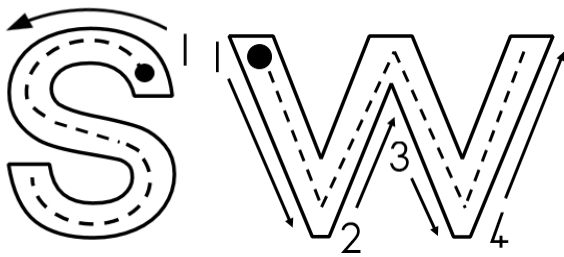

Omkring al die sw-klanke.

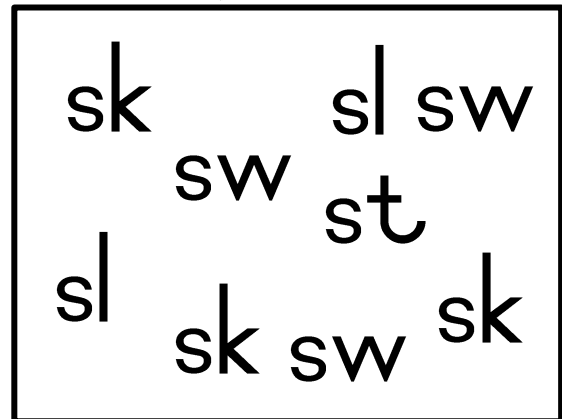

Soek die sw-woorde en kleur dit in.

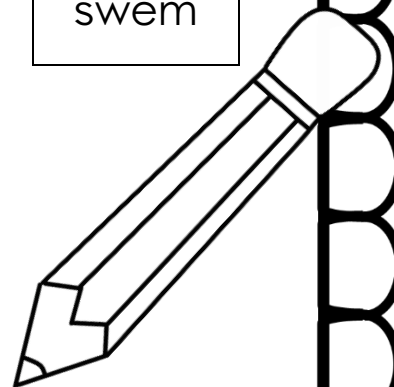

s	w	i	k	r	k	r	s	a	i
r	r	a	c	l	o	a	w	v	r
s	w	e	e	r	y	s	a	r	k
u	k	r	a	a	k	c	a	a	s
s	w	a	a	i	k	p	n	a	w
g	p	r	u	i	m	a	p	g	e
k	r	u	i	s	d	y	b	k	l
s	w	e	m	v	r	u	g	e	n

swaan
swik
sweer
swaai
swel
swem





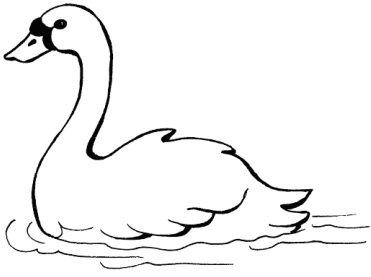

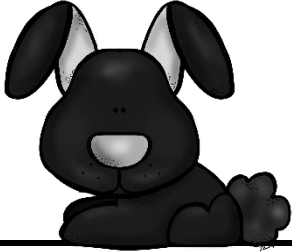
# sw-klank

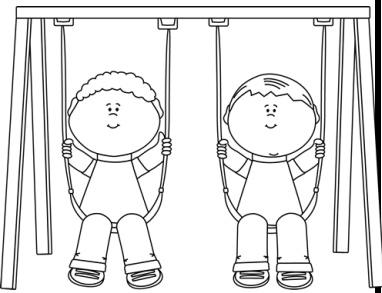
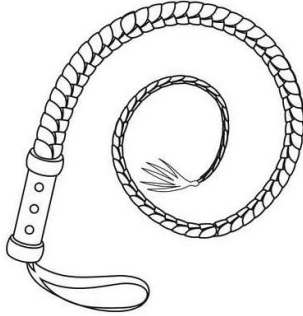
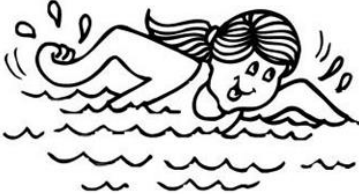
Skryf die woord vir elke prent en onderstreep die sw-klank.

		Die kleur van die hasie is _____. 
<input type="text"/>	<input type="text"/>	<input type="text"/>

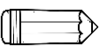
		
<input type="text"/>	<input type="text"/>	<input type="text"/>

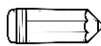
Bou die sw-woorde.

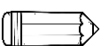
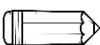
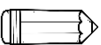
 SW	—	aai	—	<input type="text"/>	 SW	—	aan	—	<input type="text"/>
 SW	—	ik	—	<input type="text"/>	 SW	—	el	—	<input type="text"/>
 SW	—	em	—	<input type="text"/>	 SW	—	eep	—	<input type="text"/>
 SW	—	eer	—	<input type="text"/>	 SW	—	eet	—	<input type="text"/>

Kleur die "st-klank" in.

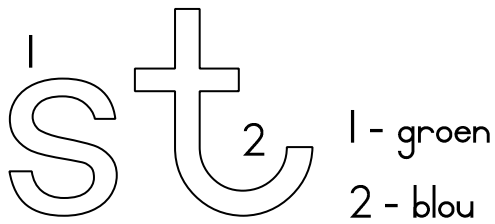

Lees die woorde.

staal	stuk	stel
stop	stil	stam
ster	stout	stoel

Trek oor die klank.

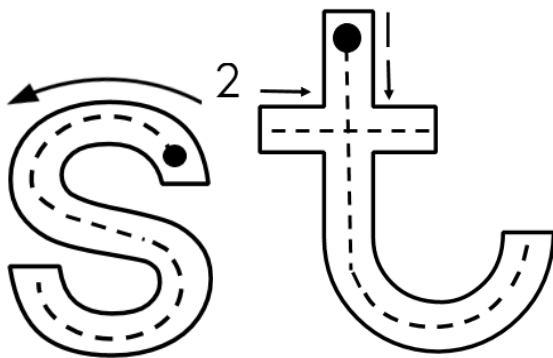

Omkring al die st-klanke.

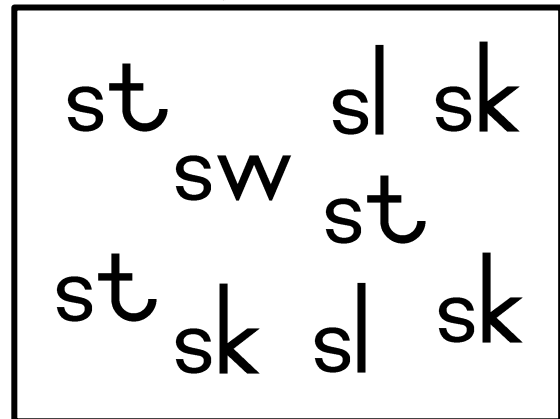

Soek die st-woorde en kleur dit in.

k	r	o	u	s	t	o	e	l	s
r	r	a	c	l	o	a	s	v	r
s	t	a	a	l	y	s	k	r	s
u	k	r	a	a	k	c	r	a	t
s	t	e	l	s	k	p	a	a	o
g	p	r	u	t	m	a	p	g	u
k	r	u	i	u	d	y	b	k	t
s	t	a	m	k	r	u	g	e	n

stoel
staal
stout
stuk
stam
stel

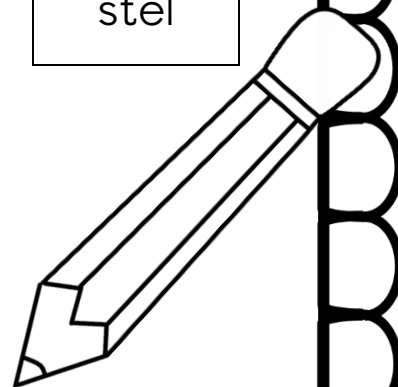





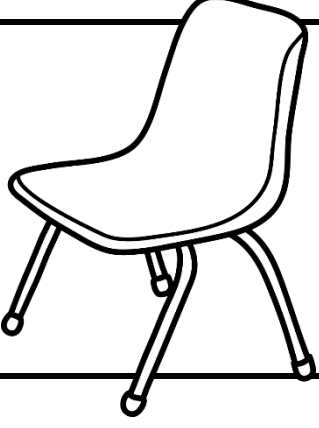
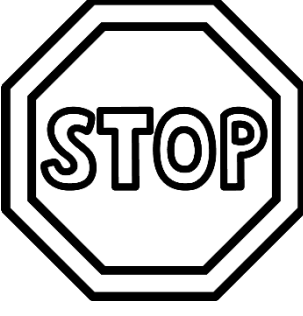
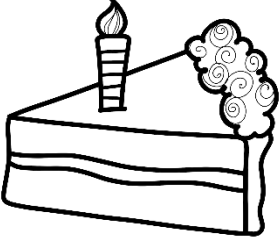



# st-klank

Skryf die woord vir elke prent en onderstreep die st-klank.

		Ek eet 'n _____ koek. 

	Juffrou sê ons moet _____ wees. 	

Bou die st-woorde.

 st	—	aal	—	<input type="text"/>	 st	—	oel	—	<input type="text"/>
 st	—	el	—	<input type="text"/>	 st	—	am	—	<input type="text"/>
 st	—	uk	—	<input type="text"/>	 st	—	op	—	<input type="text"/>
 st	—	out	—	<input type="text"/>	 st	—	er	—	<input type="text"/>



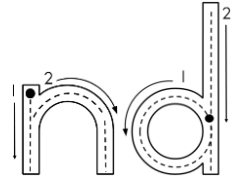

# Woorde wat eindig op -nd

Skryf die woorde by die regte prent. Onderstreep die nd-klank.

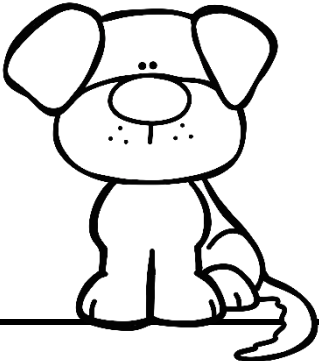

hand	sand	tand	mond	rand
kind	wind	band	hond	

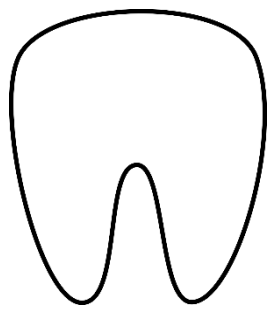
<p>Klara is 6 jaar oud. Sy is nie 'n grootmens nie. Sy is 'n _____.</p> 		

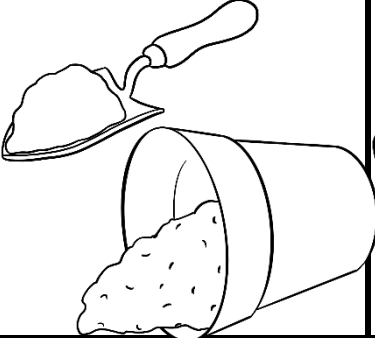
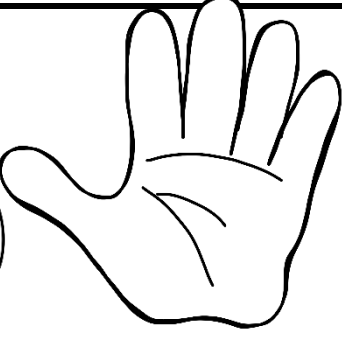
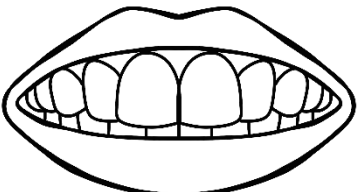

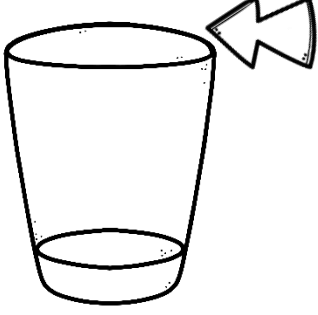
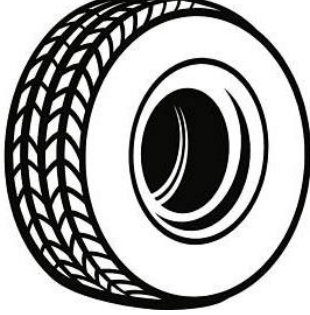
# Woorde wat eindig op -rk

Skryf die woorde by die regte prent. Onderstreep die rk-klank.

hark	park	mark	werk
vrk	vark	merk	kerk

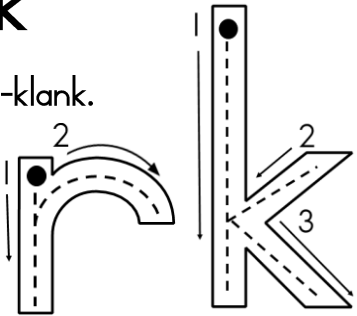





	Die man _____ baie hard, 

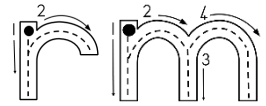

# Woorde wat eindig op -rm

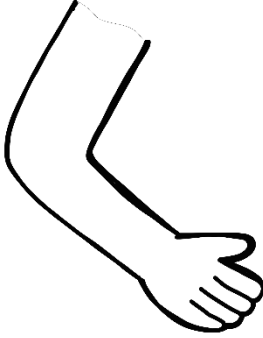
Skryf die woorde by die regte prent. Onderstreep die rm-klank.

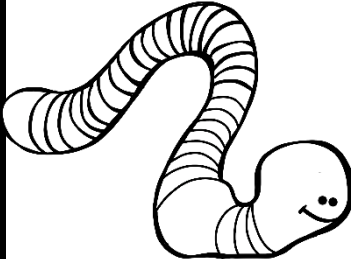

arm	alarm	kerm	warm
wurm	derm	swerm	

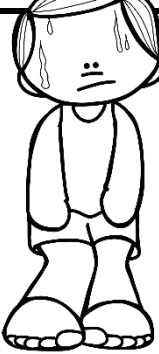
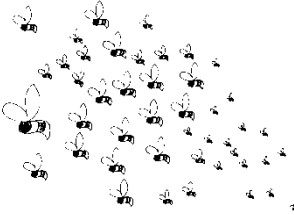
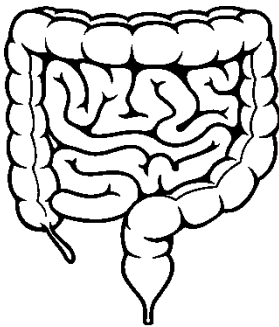
	“opstaan tyd!” 	

	Ek sien 'n _____ bye. 	

Die seun _____ vir nog lekkergoed.	

Onderstreep die aai, oei, ooi en eeu-klank met  
kleurpotlood.

aa

oe

oo

ee

haai

laai

blaai

raai

saai

waai

kwaai

kraai

swaai

braai

draai

slaai

koei

boei

bloei

vloei

loei

roei

groei

stoei

broei

gloei

mooi

rooi

hooi

gooi

nooi

kooi

vlooi

strooi

prooi

eeu

meeu

leeu

spreeu

skreeu

sneeu

seeleeu

seemeeu

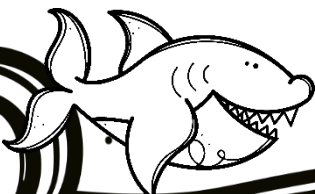
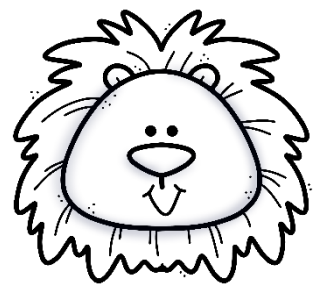

Sê die prent se naam. Luister na die klank en vul die regte klank in.

aai, oei, ooi, eeu



kw\_\_\_

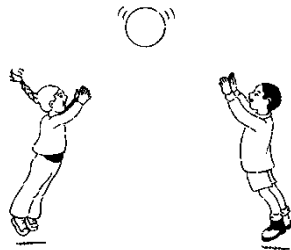

g\_\_\_

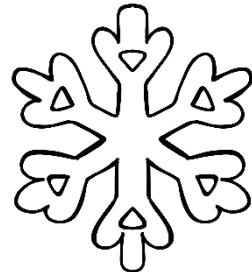

sn\_\_\_

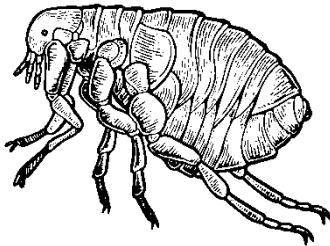

vl\_\_\_

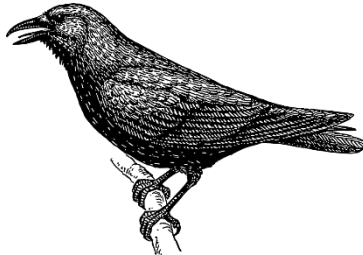

kr\_\_\_



w\_\_\_

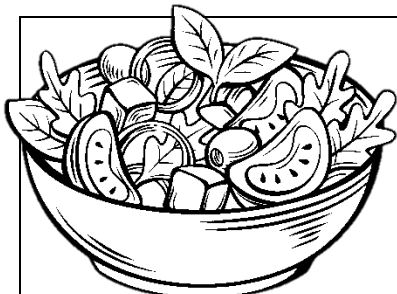

sl\_\_\_



r\_\_\_



skr\_\_\_



k\_\_\_



h\_\_\_

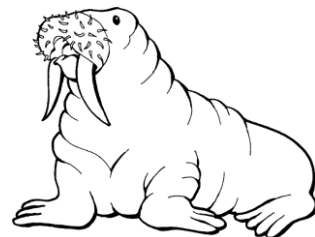

seel\_\_\_