

Mathematics
Assessment Task Term 1
Grade 1

Name and surname: _____

Date: _____

Task 1

Section		Mark obtained
1. Numbers, operations and relationships	30	
2. Patterns, functions and algebra	5	
3. Space and Shape	6	
4. Measurement	6	
5. Data Handling	3	
	Total	50

Section I: Numbers, operations and relationships

I.1. Count how many apples are on each dice and write the number symbol and the number name. (8)

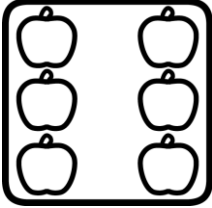
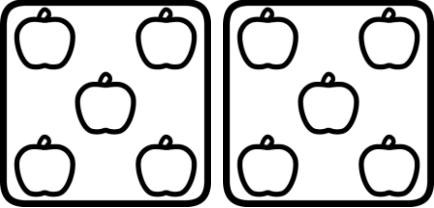
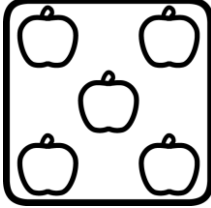
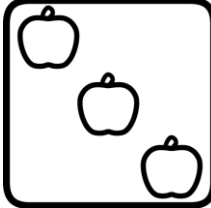

	Number symbol	Number Name
		
		
		
		

Total: ___ / 8

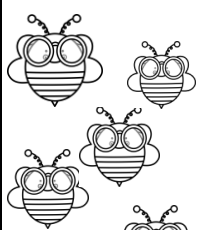
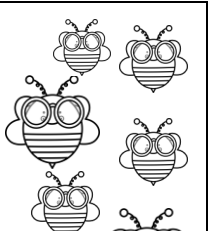
I.2.

	
<input style="width: 50px; height: 30px;" type="text"/>	<input style="width: 50px; height: 30px;" type="text"/>

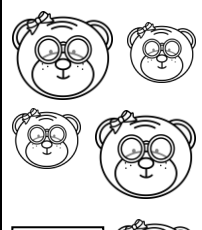
Make a **V** in the box with most bees. 2

	
<input style="width: 50px; height: 30px;" type="text"/>	<input style="width: 50px; height: 30px;" type="text"/>

Make a **V** in the box with the least bears.

Total: ___ / 2

- 1.3. Lisa's mother buys her 5 pencils for school. She lost three of the pencils. How many pencils does she have left? (1)

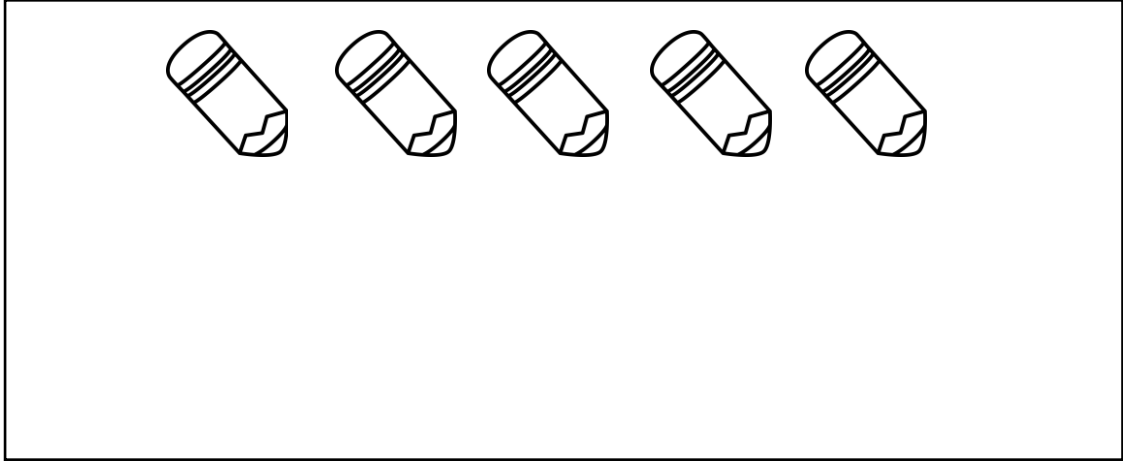

- 1.4. Jaco's mother bakes 3 cupcakes for his birthday. His grandmother bakes another 2. How many cupcakes did they bake altogether? (1)

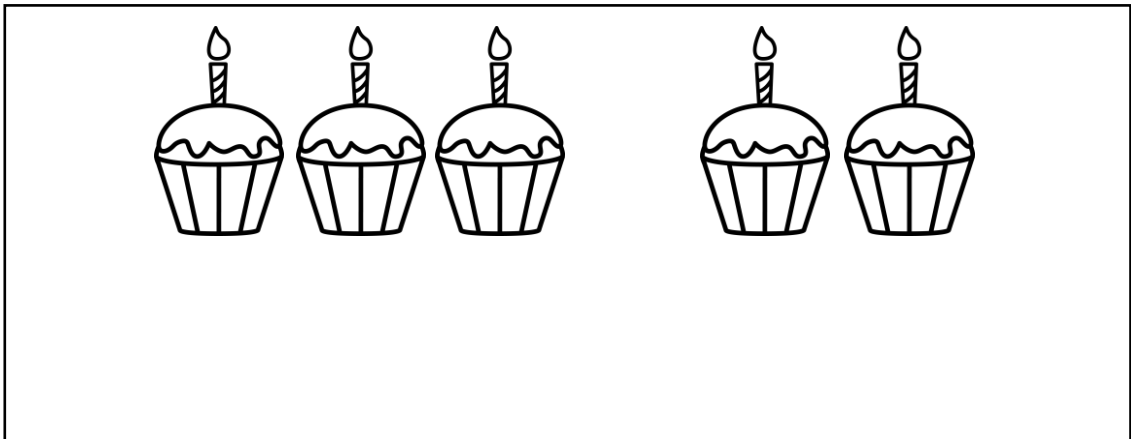

- 1.5. Order the numbers in the heart from the smallest to largest by writing it on the line. (1)

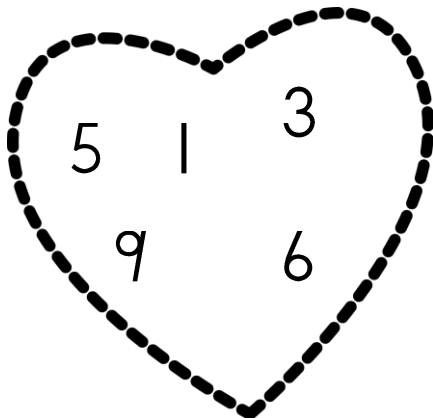

3

- 1.6. Order the numbers in the heart from the largest to smallest by writing it on the line. (1)

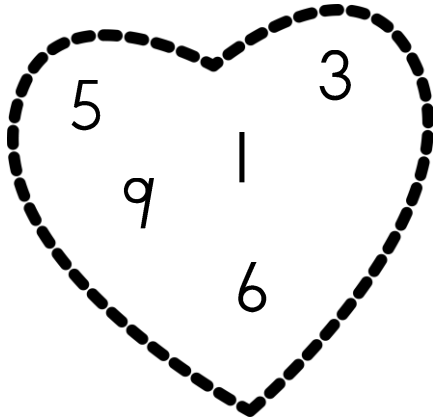

- 1.7. There are 4 sweets. David and Gary want to divide the sweets equally so that everyone gets the same amount of sweets. Help them to divide it. (1)

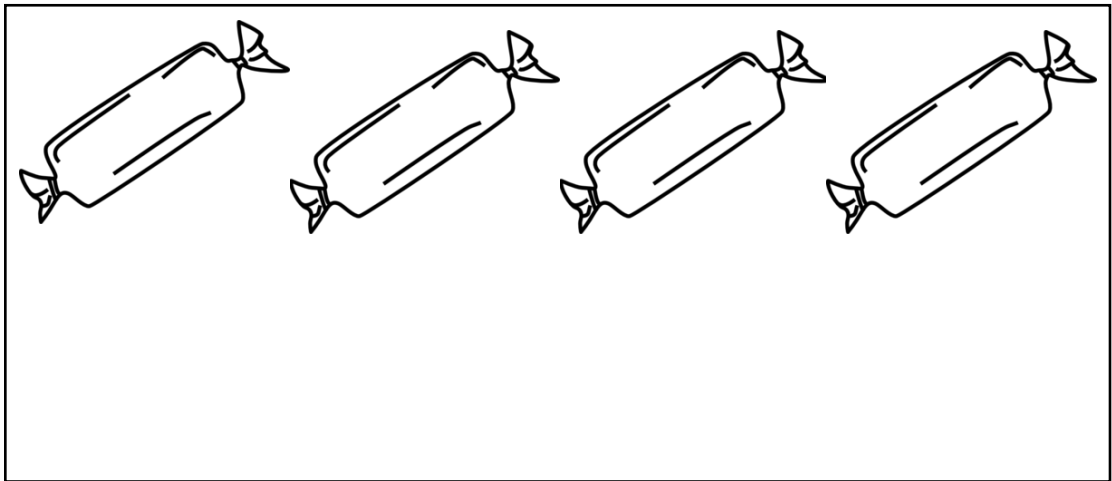

- 1.8. Complete the table. (8)

1. Which number is less, 3 or 5?	
2. Which number is more, 4 or 5?	

3. What number comes before 2?	
4. What number comes after 3?	
5. The number between 1 and 3	
6. Which number is 2 more than 3?	
7. What number is 1 less than 5?	
8. Which number is 2 more than 2?	

Total Section I: ____ / 23

Section 2: Patterns, Functions and Algebra

2.1. Expand the following patterns by drawing one more set. (2)

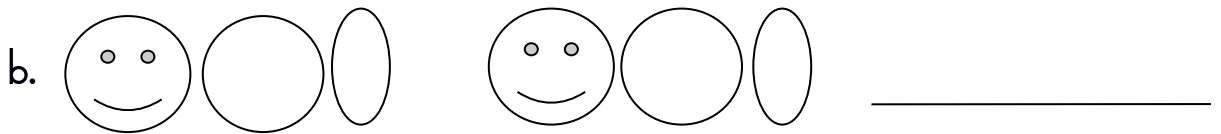

2.2. Complete the missing numbers on the number line. (3)

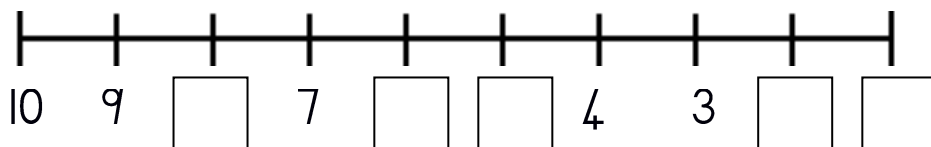
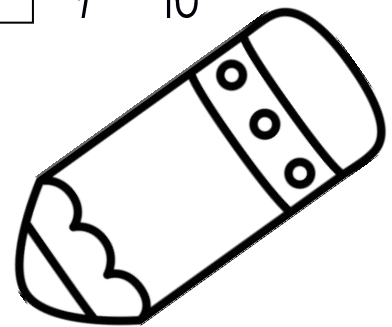
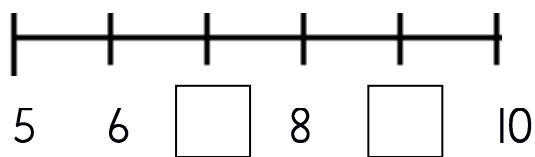
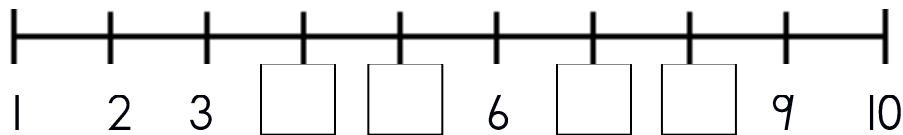

Total Section 2: ____ / 5

Section 3: Space and Shape

3.1 Draw a ball under the table and then draw a bowl of fruit on top of the table. (2)

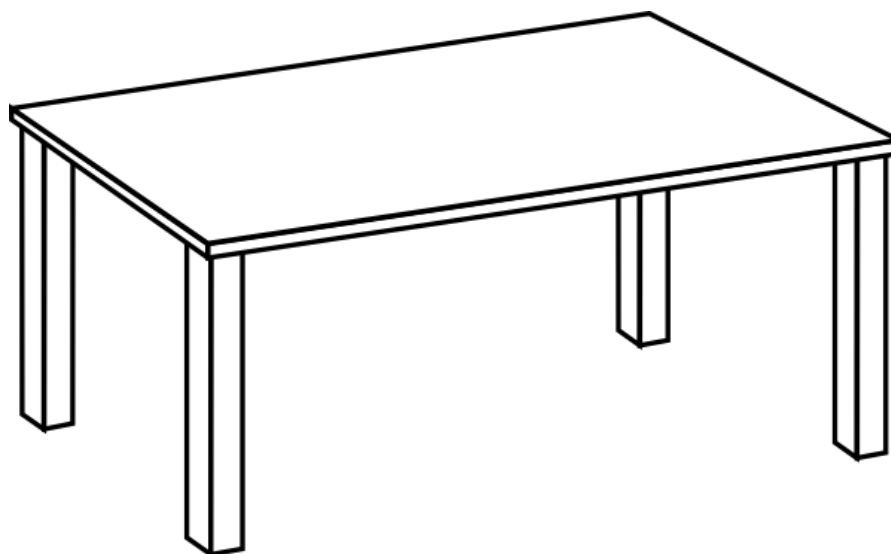

3.2. The following items shaped like a ball or a box? ($\frac{1}{2} \times 2 = 1$)



box
ball

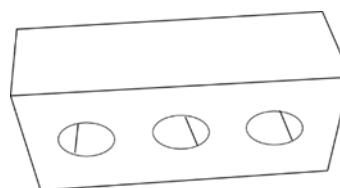

box
ball

3.3. Count the shapes and write the amount in the blocks. (3)

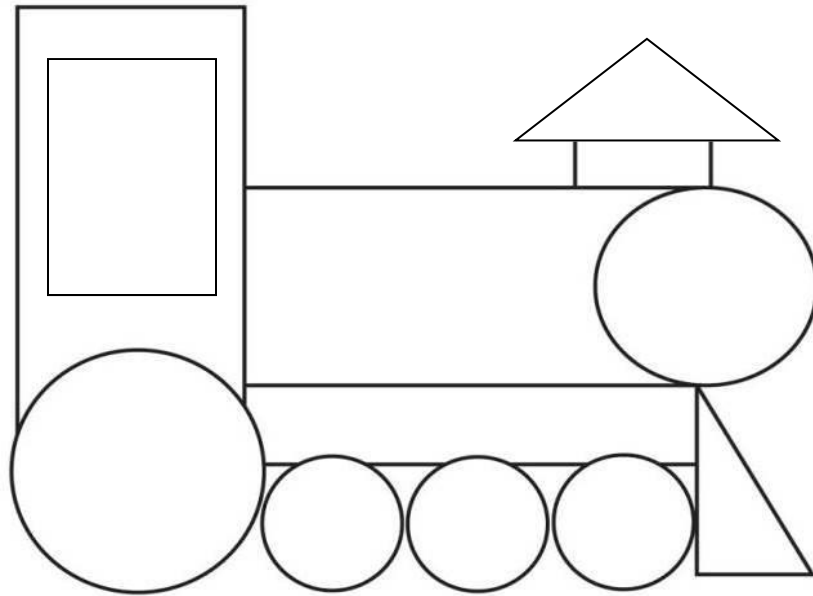

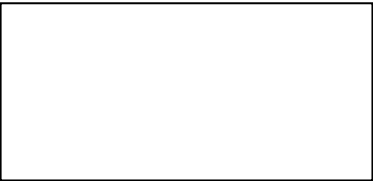
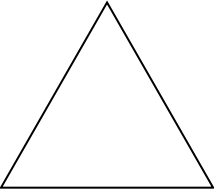
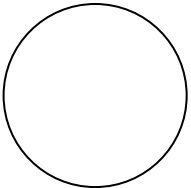
Shape	Amount
 rectangle	
 triangle	
 circle	

Total Section 3: ___ / 6

Section 4: Measurement

4.1. Answer the questions about the picture. (3)

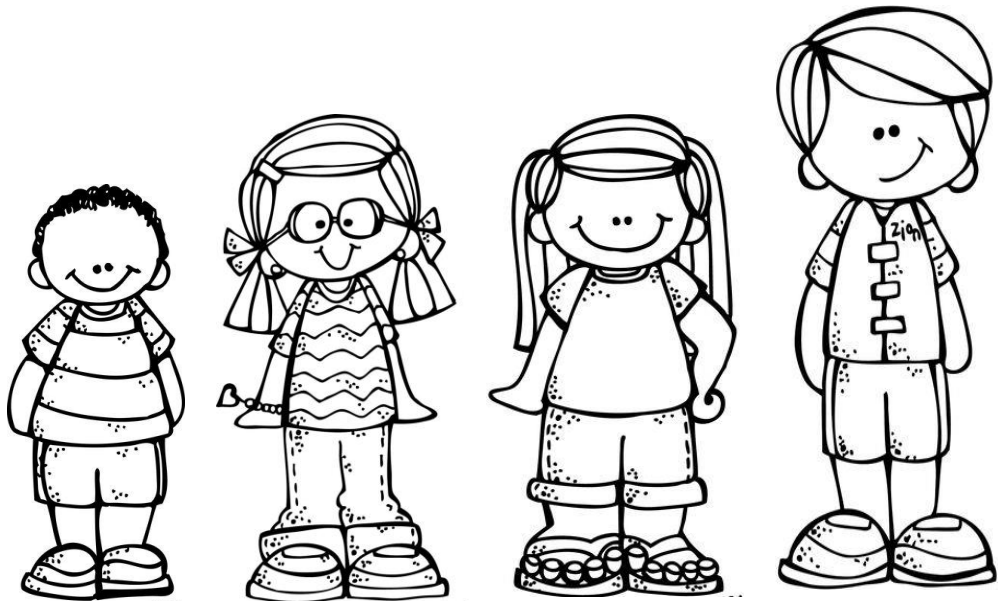

Ben

Lisa

Jana

Jaco

- a. Who is the tallest? _____ (1)
- b. Who is the shortest? _____ (1)
- c. _____ and _____ are the same length. (1)

4.2. Complete the months of the year. (3)

January, _____, March, April, _____,

June, July, _____, September.

4.3. Look at the picture and decide when it is happening:

morning, afternoon or evening.

(2)



bedtime

morning
afternoon
evening



breakfast

morning
afternoon
evening

4.4. Fill in: longer, shorter or wider.

(2)

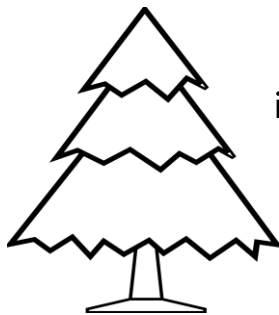

is

than



is

than



10

4.5. Look at the pictures and write which one you think is heavier.

(2)

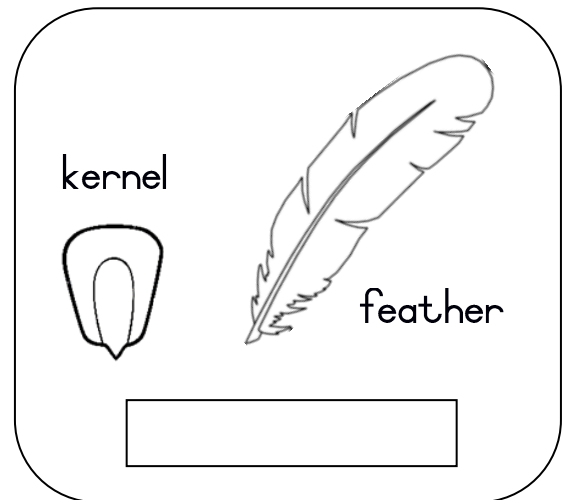
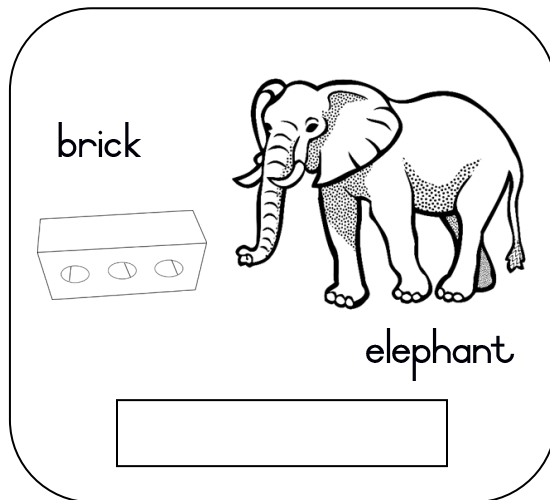

Total Section 4: ___ / 12

Processed mark Section 4 - ($12 \times \frac{1}{2} = 6$): ___ / 6

Section 5: Data Handling

Sort the pictures by drawing them in the correct column in the table and answer the questions. (3)

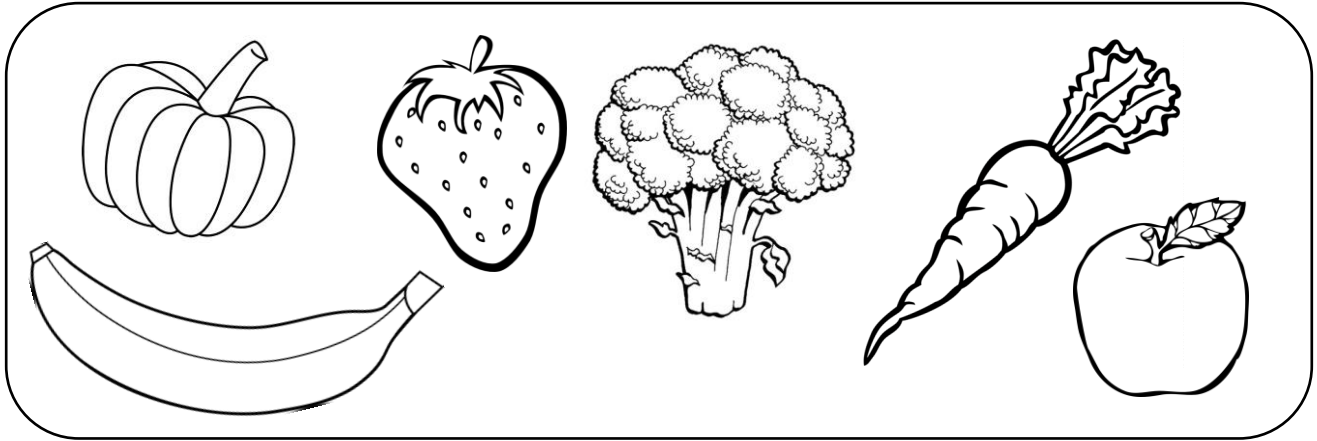

Vegetables	Fruits
$\frac{1}{2}$	$\frac{1}{2}$

$$\left(\frac{1}{2} + \frac{1}{2} = 1\right)$$

1. How many fruits are there? _____ (1)
2. How many vegetables are there?
_____ (1)

Total Section 5: ___ / 3