

# Wiskunde

Graad 1 - Kwartaal 4

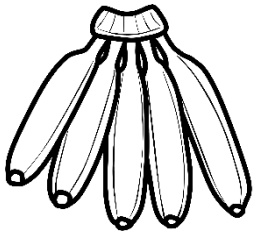

5

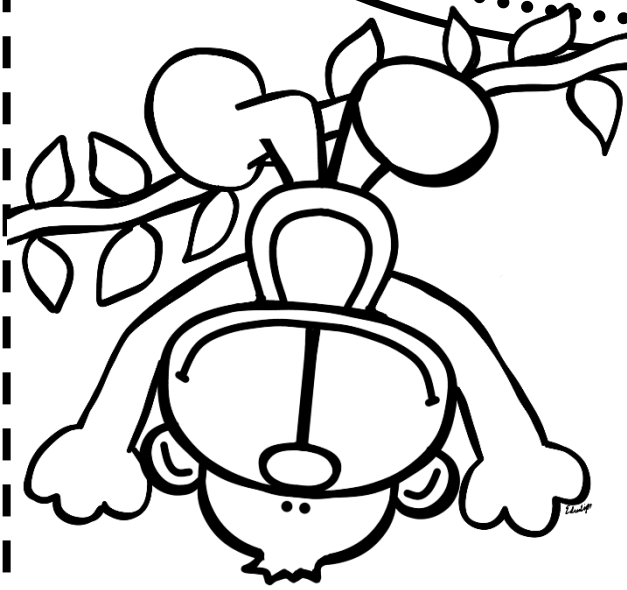
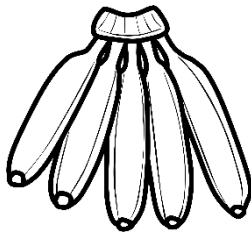

10

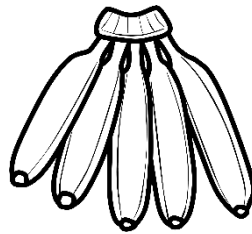

15

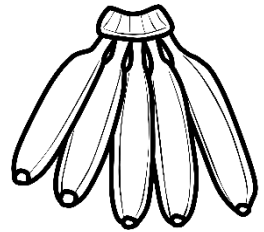

20

Naam:

# Getalname en getalsimbole

Skryf die getalnaam vir die getalsimbole.

5	_____	3	_____
7	_____	9	_____
1	_____	4	_____
6	_____	10	_____
8	_____	2	_____

Skryf die getalsimbool vir die getalname.

tien	_____	twee	_____
nege	_____	ses	_____
een	_____	agt	_____
drie	_____	sewe	_____
vier	_____	vyf	_____

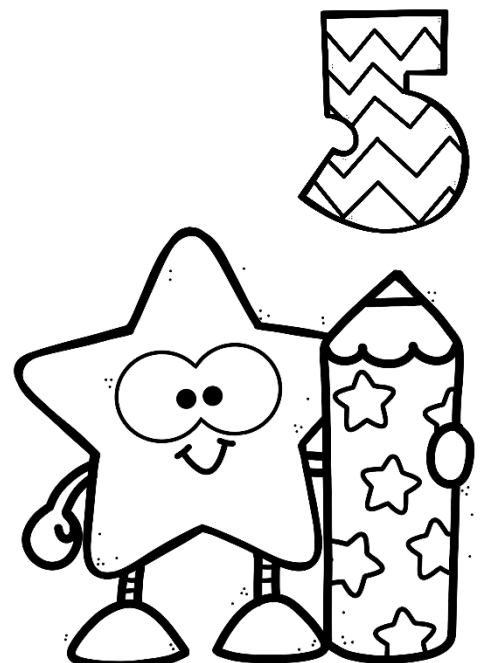

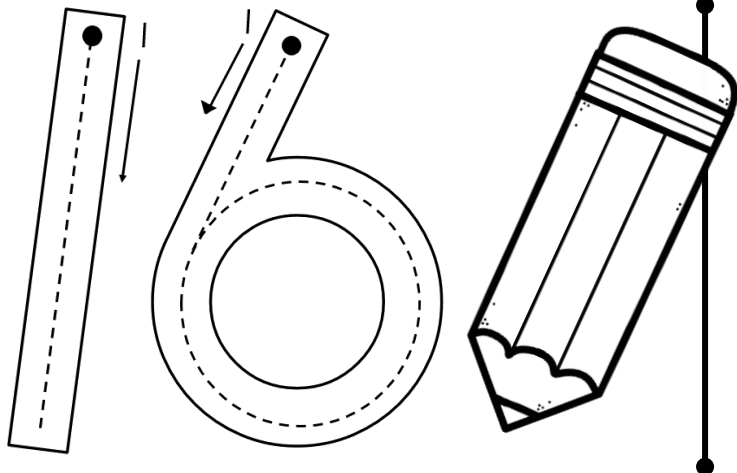

Teken 16 sirkels in die blokkies.

Skryf oor die stippellyn en voltooi dan die res van die lyn.

16 16

16 16

Voltooi die getalle.

0	1	2																	16
---	---	---	--	--	--	--	--	--	--	--	--	--	--	--	--	--	--	--	----

Kleur 16 visse in.

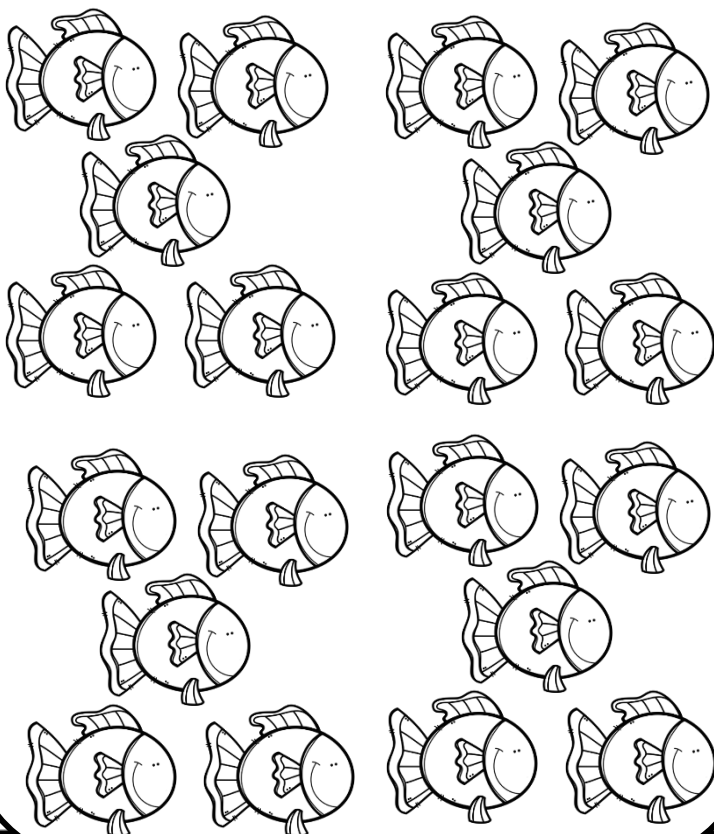

Kleur die getal 16 in.

18	16	20	19
17	19	20	16
20	16	16	19
16	18	16	20

Minder as en meer as

Wat is 1 minder as 16? \_\_\_\_

Wat is 1 meer as 16? \_\_\_\_

Wat is 2 minder as 16? \_\_\_\_

Wat is 2 meer as 16? \_\_\_\_

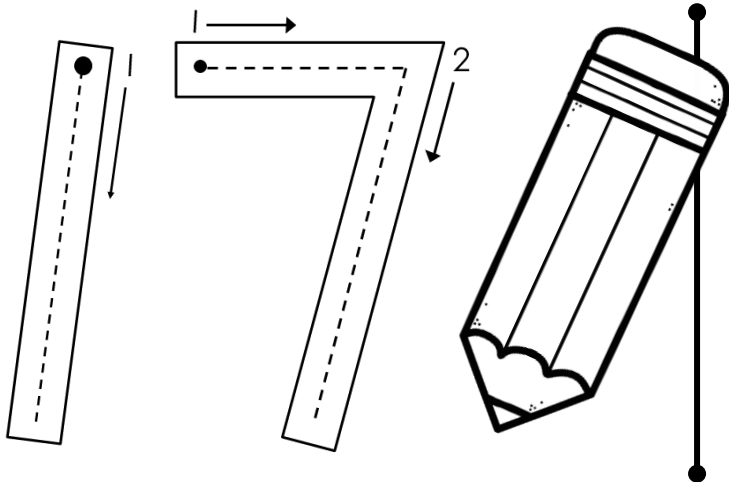

Teken 17 sirkels in die blokkies.

Skryf oor die stippellyn en voltooi dan die res van die lyn.

seventeen

17

Voltooi die getalle.

0	1	2																		17
---	---	---	--	--	--	--	--	--	--	--	--	--	--	--	--	--	--	--	--	----

Kleur 17 visse in.

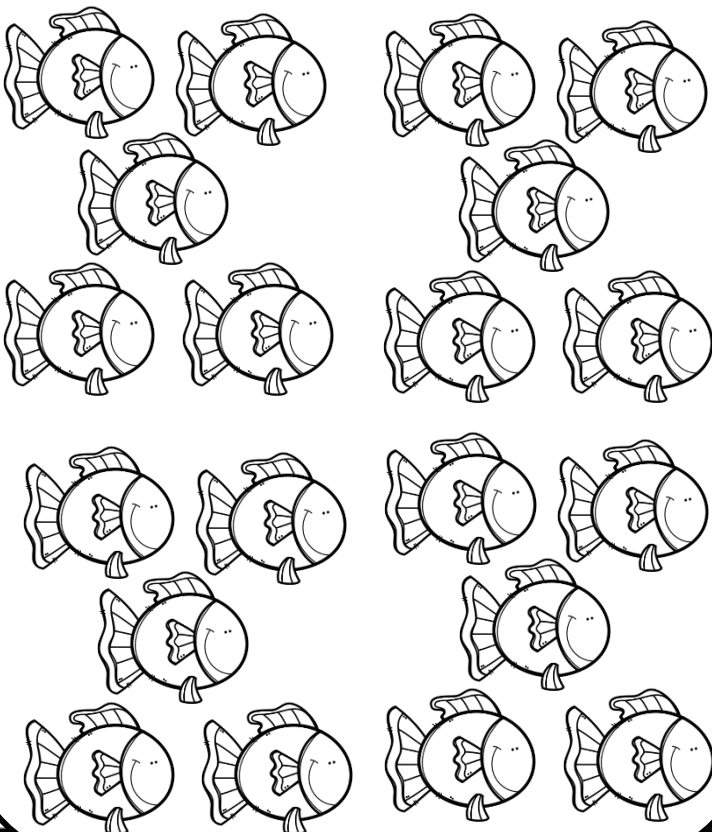

Kleur die getal 17 in.

18	16	17	19
17	19	20	16
20	16	17	19
17	18	16	20

Minder as en meer as

Wat is 1 minder as 17? \_\_\_\_

Wat is 1 meer as 17? \_\_\_\_

Wat is 2 minder as 17? \_\_\_\_

Wat is 2 meer as 17? \_\_\_\_

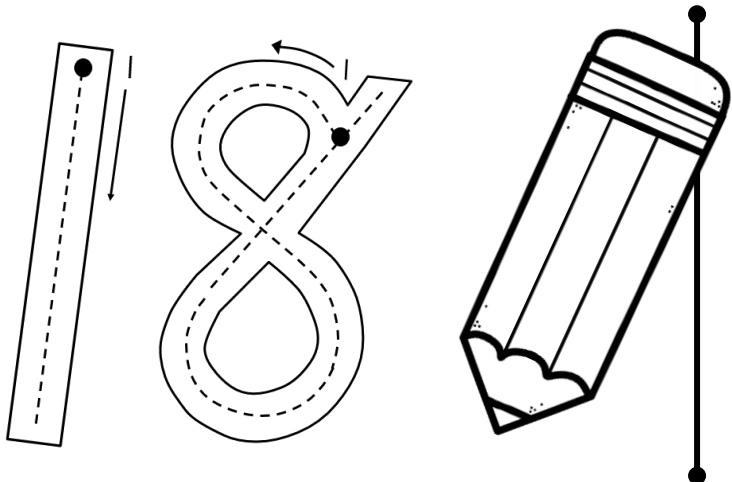

Teken 18 sirkels in die blokkies.

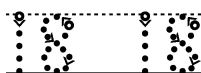
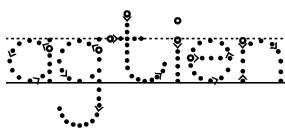

Skryf oor die stippellyn en voltooi dan die res van die lyn.



Voltooi die getalle.

0	1	2																	18
---	---	---	--	--	--	--	--	--	--	--	--	--	--	--	--	--	--	--	----

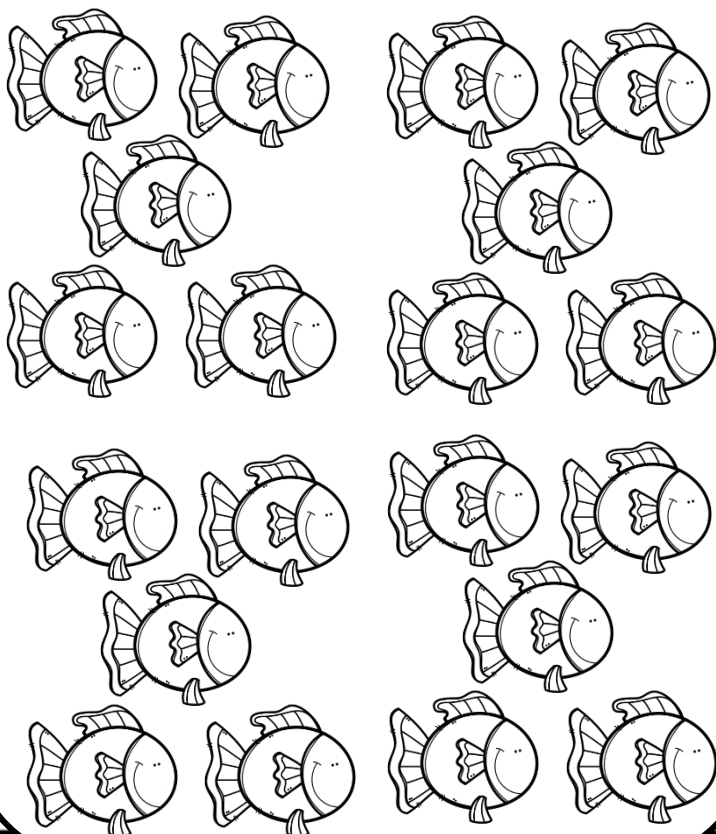
Kleur 18 visse in.



Kleur die getal 18 in.

18	16	17	19
17	19	20	18
18	16	17	19
17	18	16	20

Minder as en meer as

Wat is 1 minder as 18? \_\_\_\_

Wat is 1 meer as 18? \_\_\_\_

Wat is 2 minder as 18? \_\_\_\_

Wat is 2 meer as 18? \_\_\_\_



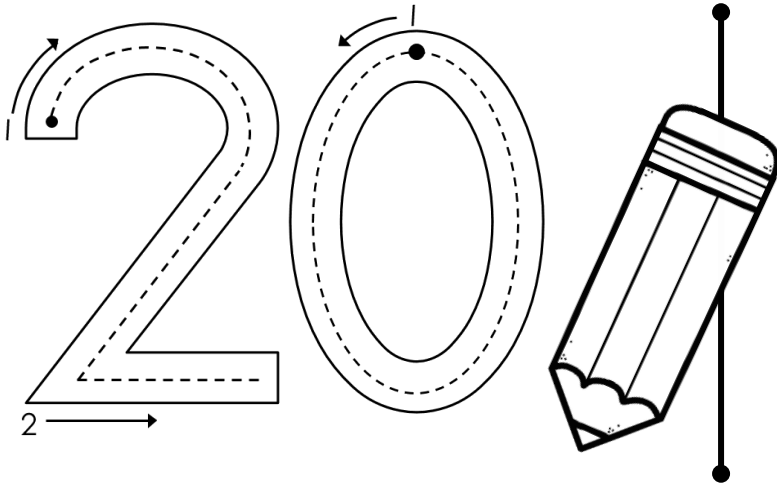

Teken 20 sirkels in die blokkies.

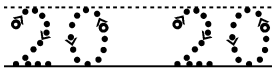
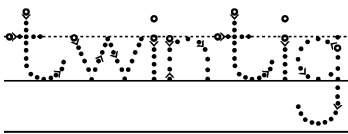

Skryf oor die stippellyn en voltooi dan die res van die lyn.



Voltooi die getalle.

0	1	2																		20
---	---	---	--	--	--	--	--	--	--	--	--	--	--	--	--	--	--	--	--	----

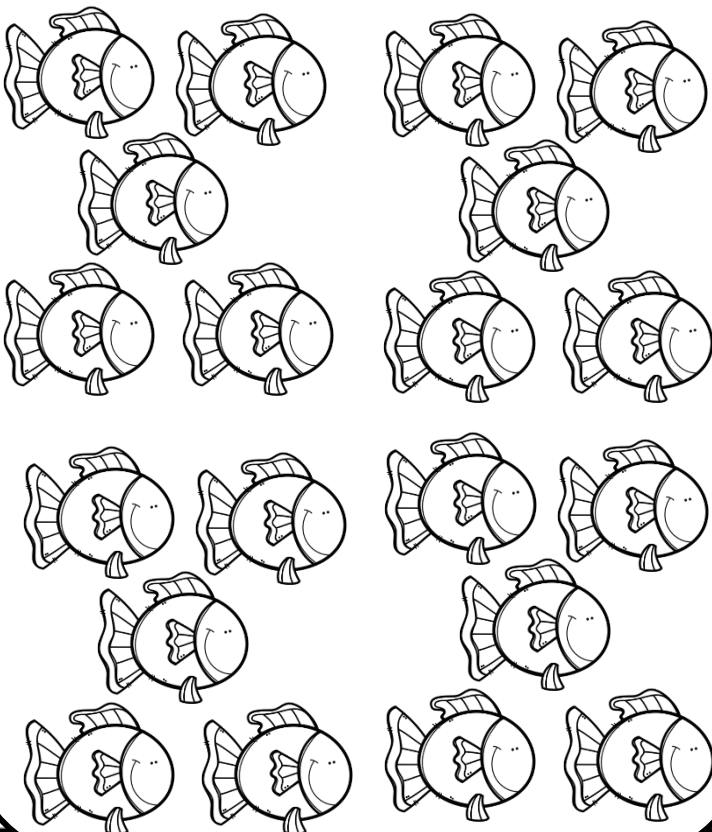
Kleur 20 visse in.



Kleur die getal 20 in.

19	16	17	19
17	19	20	18
18	16	17	19
19	18	16	20

Minder as en meer as

Wat is 1 minder as 20? \_\_\_\_

Wat is 1 meer as 20? \_\_\_\_

Wat is 2 minder as 20? \_\_\_\_

Wat is 2 meer as 20? \_\_\_\_

Pas die getalnaam by die getalsimbool.

0

1

2

3

4

5

6

7

8

9

10

11

12

13

14

15

16

17

18

19

20

twee

twintig

vyf

negentien

dertien

agtien

sewentien

nul

sewe

veertien

een

drie

agt

vier

vyftien

sestien

nege

elf

tien

twaaif

ses



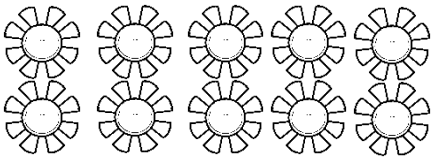
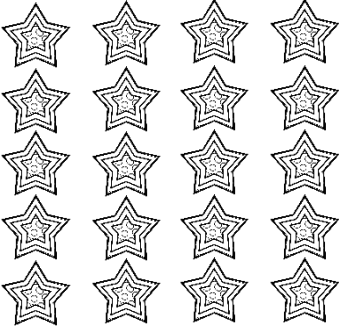
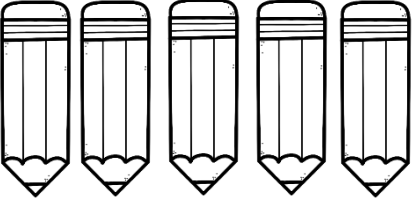

Tel die prente en skryf die getalsimbool. Waar moontlik tel in groepe van 2, 5 of 10 om die prente makliker te kan tel.

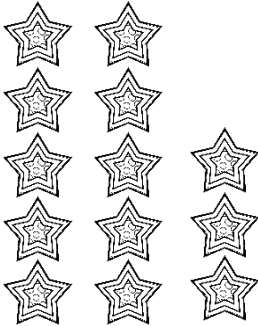
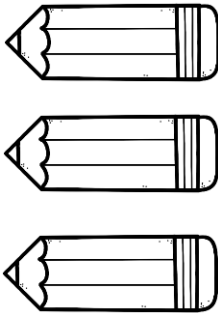
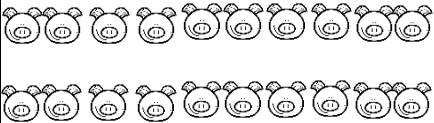
		
<input type="text"/>	<input type="text"/>	<input type="text"/>

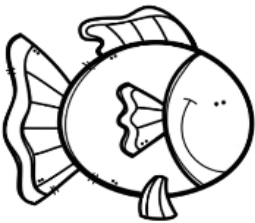
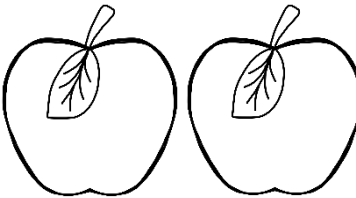
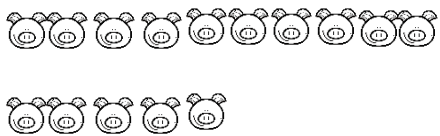
		
<input type="text"/>	<input type="text"/>	<input type="text"/>

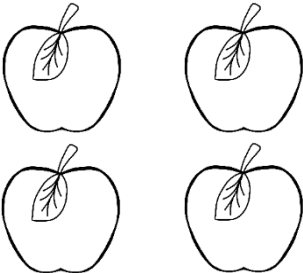
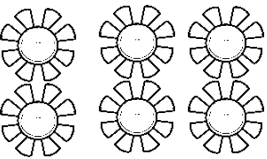
		
<input type="text"/>	<input type="text"/>	<input type="text"/>

		
<input type="text"/>	<input type="text"/>	<input type="text"/>

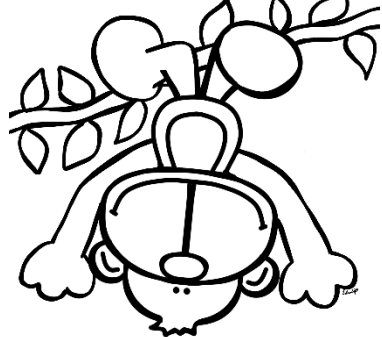

# Groep van 2

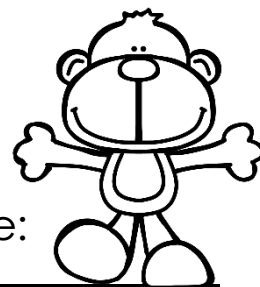

Tel die piesangs deur groepering.

Skryf dan 'n getalsin vir elk van die volgende:

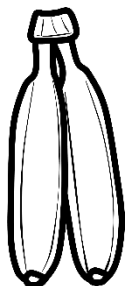

\_\_\_\_\_ = \_\_\_\_\_ piesangs

\_\_\_\_\_ groepe van \_\_\_\_\_ = \_\_\_\_\_ piesangs

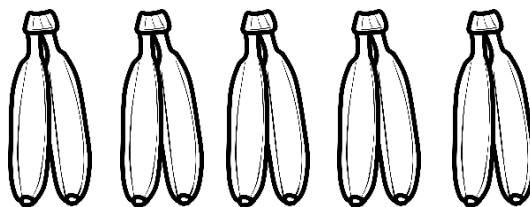

\_\_\_\_\_ = \_\_\_\_\_ piesangs

\_\_\_\_\_ groepe van \_\_\_\_\_ = \_\_\_\_\_ piesangs

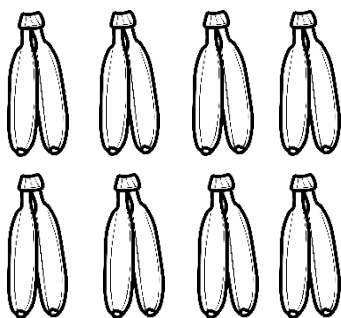

\_\_\_\_\_ = \_\_\_\_\_ piesangs

\_\_\_\_\_ groepe van \_\_\_\_\_ = \_\_\_\_\_ piesangs

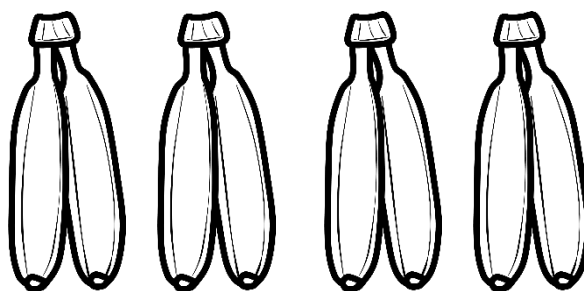

\_\_\_\_\_ = \_\_\_\_\_ piesangs

\_\_\_\_\_ groepe van \_\_\_\_\_ = \_\_\_\_\_ piesangs

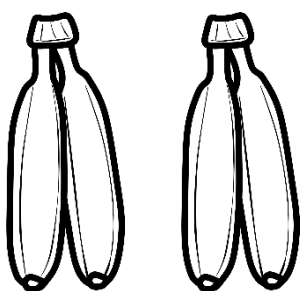

\_\_\_\_\_ = \_\_\_\_\_ piesangs

\_\_\_\_\_ groepe van \_\_\_\_\_ = \_\_\_\_\_ piesangs

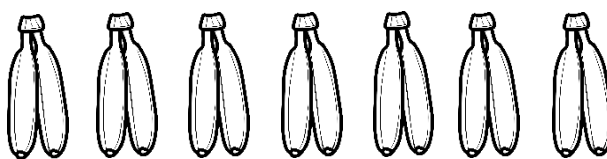

\_\_\_\_\_ = \_\_\_\_\_ piesangs

\_\_\_\_\_ groepe van \_\_\_\_\_ = \_\_\_\_\_ piesangs

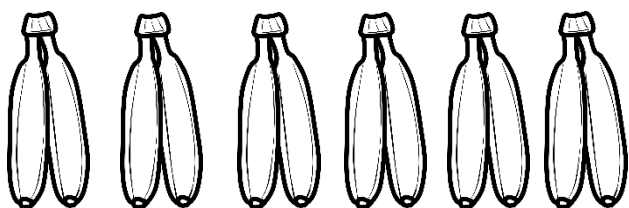

\_\_\_\_\_ = \_\_\_\_\_ piesangs

\_\_\_\_\_ groepe van \_\_\_\_\_ = \_\_\_\_\_ piesangs

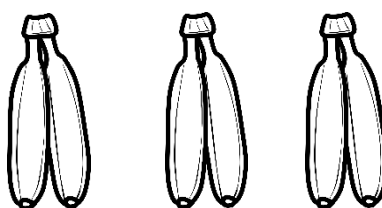

\_\_\_\_\_ = \_\_\_\_\_ piesangs

\_\_\_\_\_ groepe van \_\_\_\_\_ = \_\_\_\_\_ piesangs

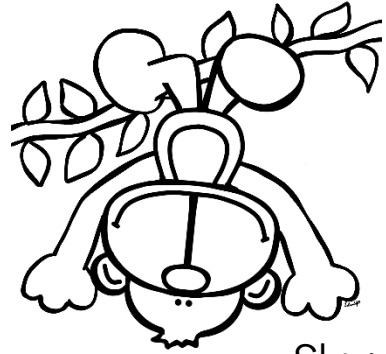

# Groepe van 3

Tel die piesangs deur groepering.

Skryf dan 'n getalsin vir elk van die volgende:

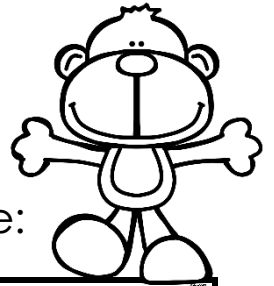

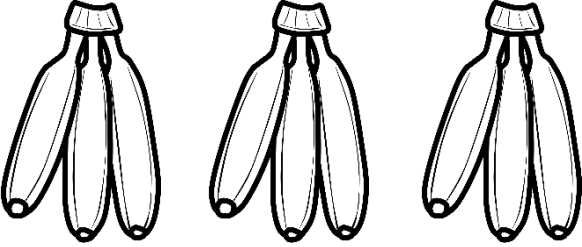
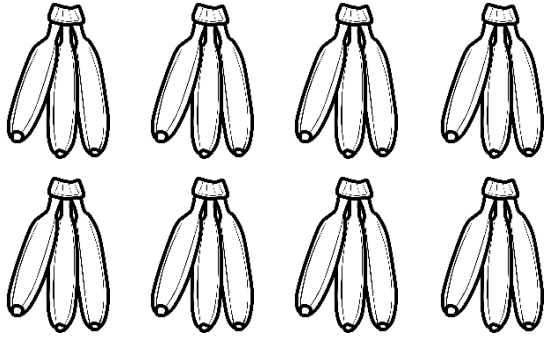
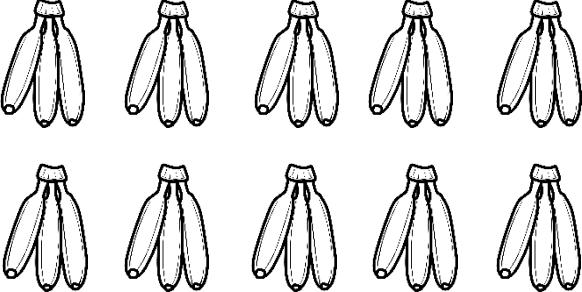
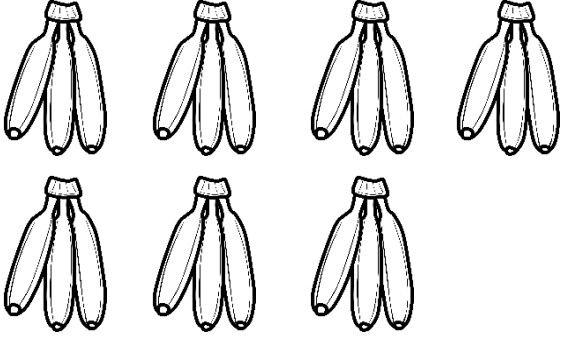
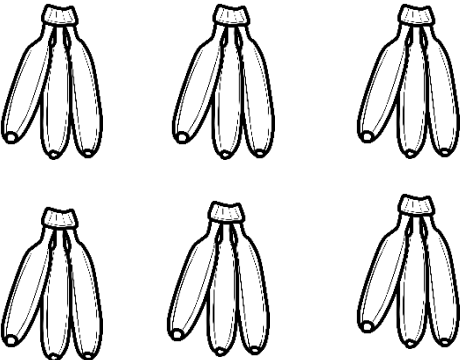
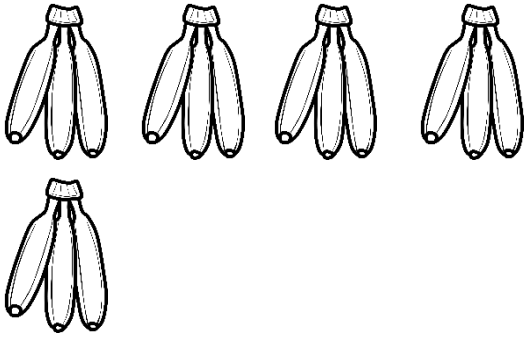
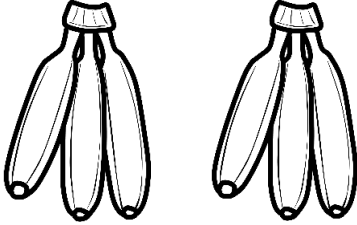
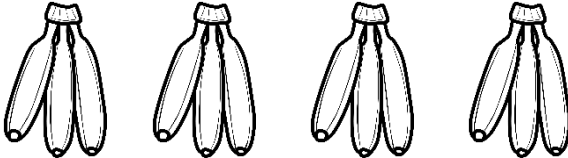
 <p>_____ = _____ piesangs          _____ groepe van _____ = _____ piesangs</p>	 <p>_____ = _____ piesangs          _____ groepe van _____ = _____ piesangs</p>
 <p>_____ = _____ piesangs          _____ groepe van _____ = _____ piesangs</p>	 <p>_____ = _____ piesangs          _____ groepe van _____ = _____ piesangs</p>
 <p>_____ = _____ piesangs          _____ groepe van _____ = _____ piesangs</p>	 <p>_____ = _____ piesangs          _____ groepe van _____ = _____ piesangs</p>
 <p>_____ = _____ piesangs          _____ groepe van _____ = _____ piesangs</p>	 <p>_____ = _____ piesangs          _____ groepe van _____ = _____ piesangs</p>



# Groepe van 4

Tel die piesangs deur groepering.

Skryf dan 'n getalsin vir elk van die volgende:

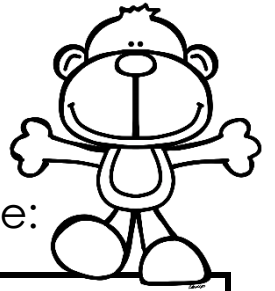

<p>_____ = _____ piesangs _____ groepe van _____ = _____ piesangs</p>	<p>_____ = _____ piesangs _____ groepe van _____ = _____ piesangs</p>
<p>_____ = _____ piesangs _____ groepe van _____ = _____ piesangs</p>	<p>_____ = _____ piesangs _____ groepe van _____ = _____ piesangs</p>
<p>_____ = _____ piesangs _____ groepe van _____ = _____ piesangs</p>	<p>_____ = _____ piesangs _____ groepe van _____ = _____ piesangs</p>
<p>_____ = _____ piesangs _____ groepe van _____ = _____ piesangs</p>	<p>_____ = _____ piesangs _____ groepe van _____ = _____ piesangs</p>



# Groeppe van 5



Tel die aarbeie in die mandjies deur groepering.

Skryf dan 'n getalsin vir elk van die volgende:

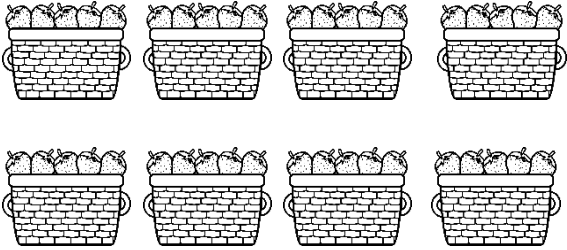

\_\_\_\_\_ = \_\_\_\_\_ aarbeie  
\_\_\_\_\_ groepe van \_\_\_\_\_ = \_\_\_\_\_ aarbeie

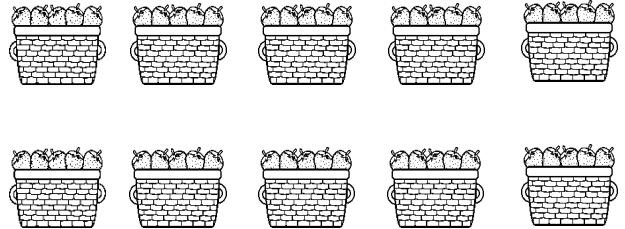

\_\_\_\_\_ = \_\_\_\_\_ aarbeie  
\_\_\_\_\_ groepe van \_\_\_\_\_ = \_\_\_\_\_ aarbeie

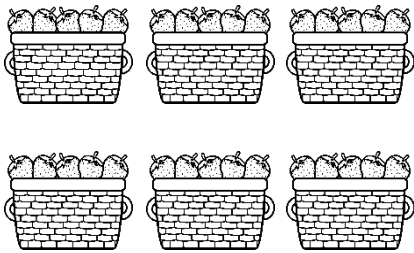

\_\_\_\_\_ = \_\_\_\_\_ aarbeie  
\_\_\_\_\_ groepe van \_\_\_\_\_ = \_\_\_\_\_ aarbeie

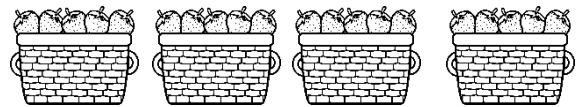

\_\_\_\_\_ = \_\_\_\_\_ aarbeie  
\_\_\_\_\_ groepe van \_\_\_\_\_ = \_\_\_\_\_ aarbeie

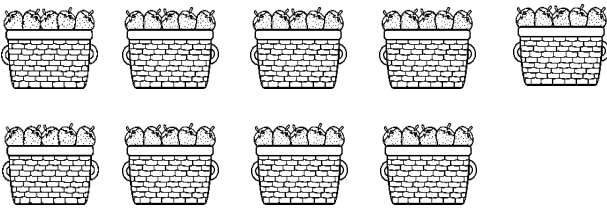

\_\_\_\_\_ = \_\_\_\_\_ aarbeie  
\_\_\_\_\_ groepe van \_\_\_\_\_ = \_\_\_\_\_ aarbeie

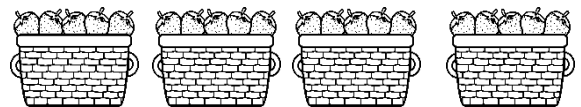

\_\_\_\_\_ = \_\_\_\_\_ aarbeie  
\_\_\_\_\_ groepe van \_\_\_\_\_ = \_\_\_\_\_ aarbeie



\_\_\_\_\_ = \_\_\_\_\_ aarbeie  
\_\_\_\_\_ groepe van \_\_\_\_\_ = \_\_\_\_\_ aarbeie

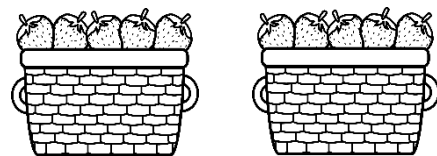

\_\_\_\_\_ = \_\_\_\_\_ aarbeie  
\_\_\_\_\_ groepe van \_\_\_\_\_ = \_\_\_\_\_ aarbeie

# Plekwaarden

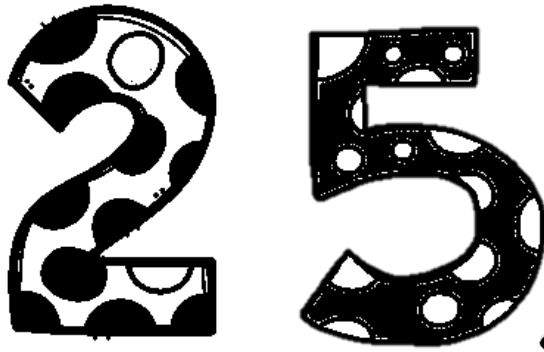

tiene



ene

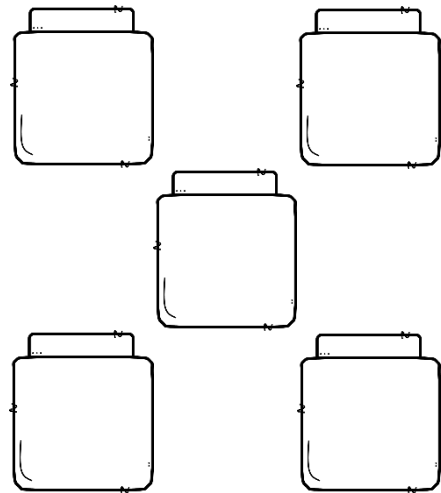
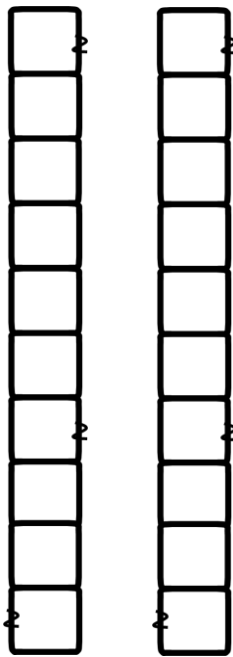

$$20 + 5 = 25$$

# Plekwaardede

Breek die getalle op in tiene en ene.  
Teken blokkies om dit te wys. Die eerste een is vir jou gedoen.

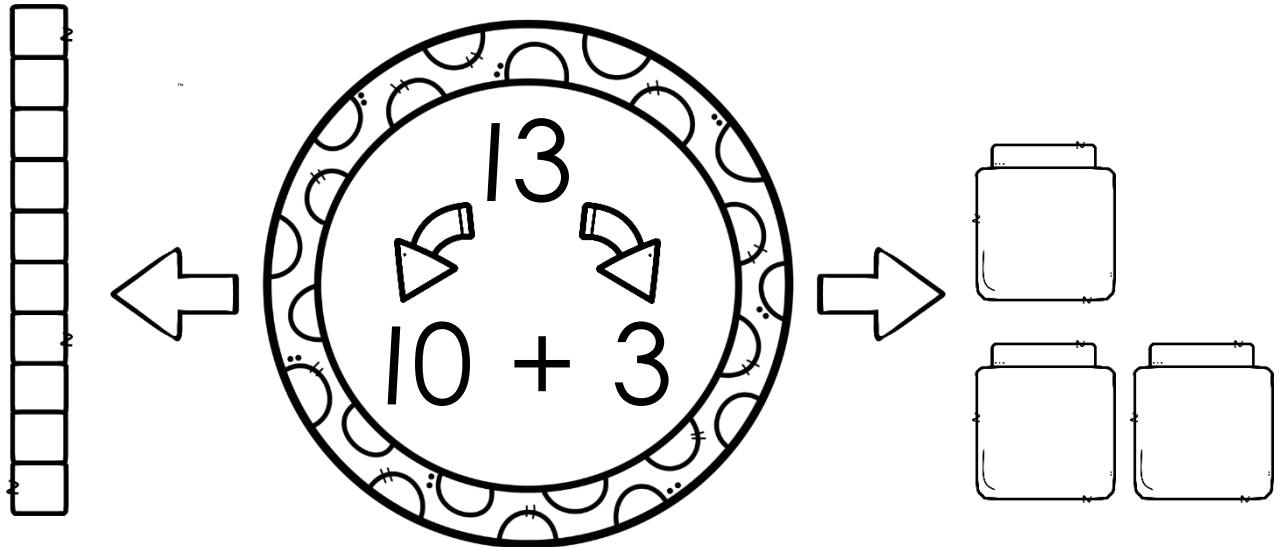

$22 = 20 + 2$

$34 = \underline{\quad} + \underline{\quad}$

$15 = \underline{\quad} + \underline{\quad}$

$33 = \underline{\quad} + \underline{\quad}$

$17 = \underline{\quad} + \underline{\quad}$

$28 = \underline{\quad} + \underline{\quad}$

Onderstreep die tiene met ROOI en die ene met GROEN.

14

39

26

13

24

21

11

27

32

18

# Voltooi die getalle

Tel in 1'e.

→ 

0	1	2		4					10			14		17	
---	---	---	--	---	--	--	--	--	----	--	--	----	--	----	--

→ 

60	61		63		65		67		69	
----	----	--	----	--	----	--	----	--	----	--

→ 

50			53	54				58		
----	--	--	----	----	--	--	--	----	--	--

Tel in 2's.

→ 

10	12	14				22			28			34
----	----	----	--	--	--	----	--	--	----	--	--	----

→ 

32	34			40	42				50		54	
----	----	--	--	----	----	--	--	--	----	--	----	--

→ 

20	22				30			36				44
----	----	--	--	--	----	--	--	----	--	--	--	----

Tel in 5'e.

→ 

5	10											65
---	----	--	--	--	--	--	--	--	--	--	--	----

→ 

30			45				65			80
----	--	--	----	--	--	--	----	--	--	----

Tel in 10's.

→ 

10			40				80
----	--	--	----	--	--	--	----

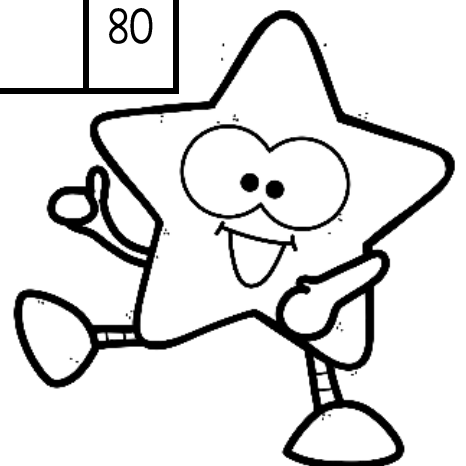



# Grootste en kleinste

Omkring die getal wat die grootste is.

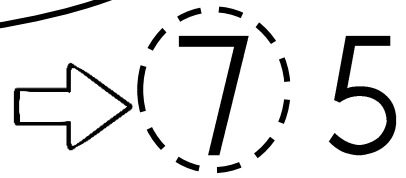

5	4	6
---	---	---

3	2	1
---	---	---

5	4	6
---	---	---

15	13	14
----	----	----

10	11	12
----	----	----

6	9	8
---	---	---

Omkring die getal wat die kleinste is.



5	4	6
---	---	---

6	9	8
---	---	---

7	6	8
---	---	---

13	14	12
----	----	----

1	2	3
---	---	---

12	10	13
----	----	----

Rangskik die getalle van die grootste na die kleinste.

5	9	7

14	12	13

4	1	2

Rangskik die getalle van die kleinste na die grootste.

6	5	8

13	12	11

9	3	6

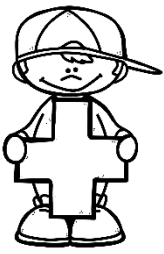

# Probleemoplossing

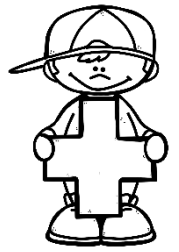

- Optelling -

Lees die woordprobleme. Skryf 'n getalsin vir elkeen. Wys jou som op die getallelyn.

Lisa het 3 koekies. Ben gee vir haar nog 14 koekies. Hoeveel koekies is daar altesaam?

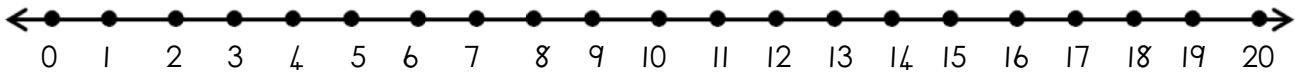

$$\underline{\quad\quad} + \underline{\quad\quad} = \underline{\quad\quad}$$

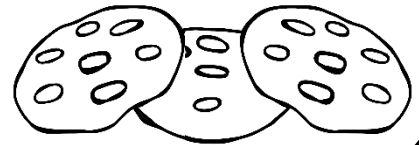

David het 5 tekenkryte. Jan het 8 tekenkryte. Hoeveel tekenkryte het hulle altesaam?

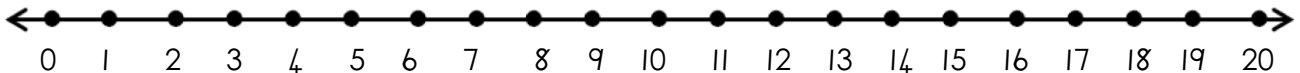

$$\underline{\quad\quad} + \underline{\quad\quad} = \underline{\quad\quad}$$

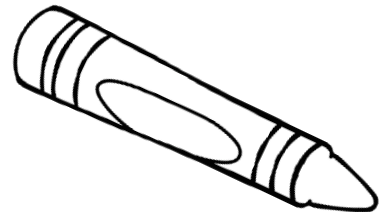

Karel het 11 lekkers. Bennie het 7 lekkers. Hoeveel lekkers het hulle altesaam?

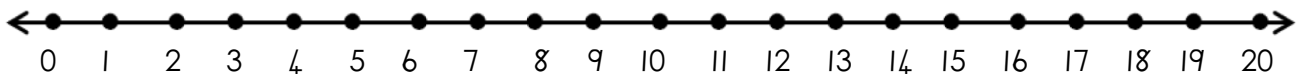

$$\underline{\quad\quad} + \underline{\quad\quad} = \underline{\quad\quad}$$



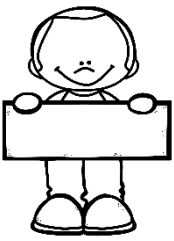

# Probleemoplossing

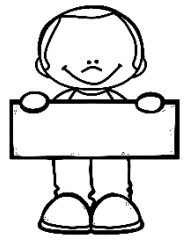

- Aftrekking -

Lees die woordprobleme. Skryf 'n getalsin vir elkeen. Wys jou som op die getallelyn.

Lisa het 17 koekies. Ben eet 9 van haar koekies. Hoeveel koekies het sy oor?

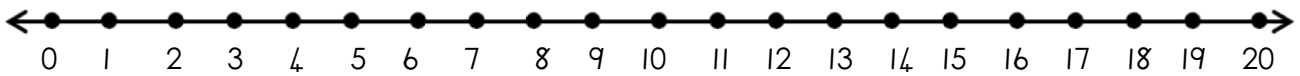

$$\underline{\hspace{2cm}} - \underline{\hspace{2cm}} = \underline{\hspace{2cm}}$$

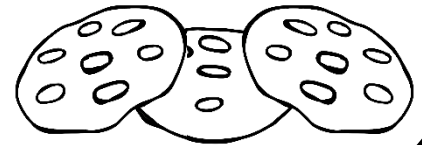

Susan het 12 albasters. Sy verloor 5 van haar albasters. Hoeveel albasters het sy oor?

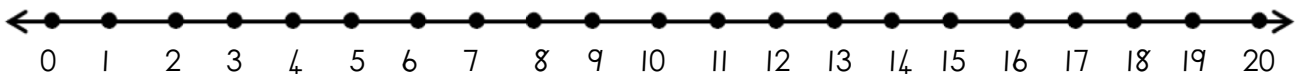

$$\underline{\hspace{2cm}} - \underline{\hspace{2cm}} = \underline{\hspace{2cm}}$$



Karel dra 10 glase op 'n skinkbord. Hy laat val die skinkbord en 4 van die glase breek. Hoeveel glase is oor?

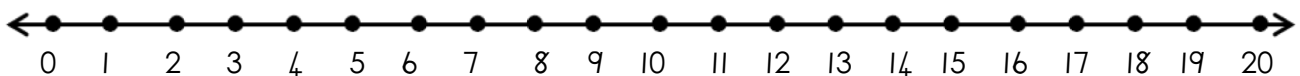

$$\underline{\hspace{2cm}} - \underline{\hspace{2cm}} = \underline{\hspace{2cm}}$$

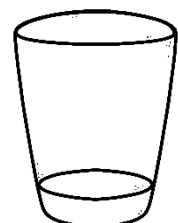

Voltooi die 100 blok.

1						7	8	9	
11	12			15	16				20
		23	24				28	29	
	32		34	35	36			39	
	42		44		46				
	52	53					58	59	60
	62		64					69	70
	72		74		76			79	
81		83	84					89	
	92		94	95				99	

# Meer en minder

minder

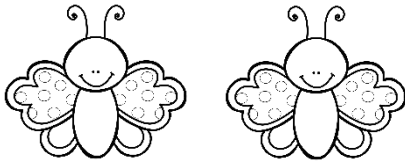

meer

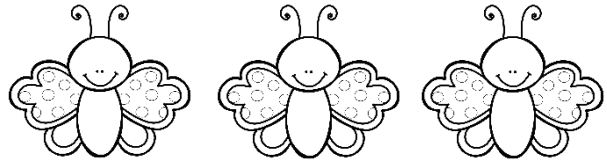

Tel die prente en skryf die getalsimbool. Kleur dan die getal wat minder is groen in en die getal wat meer is pers in.

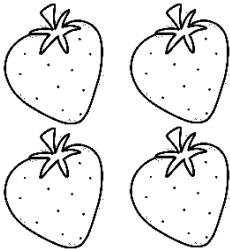
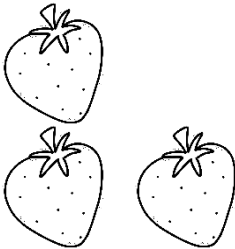
	
<input type="text"/>	<input type="text"/>

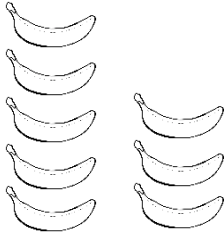
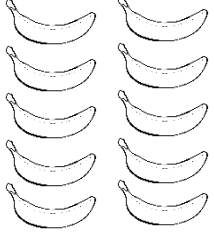
	
<input type="text"/>	<input type="text"/>

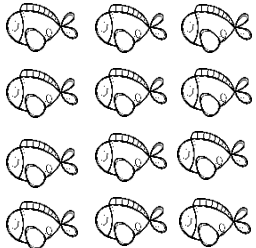
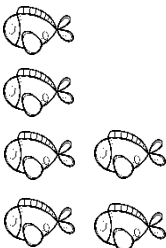
	
<input type="text"/>	<input type="text"/>

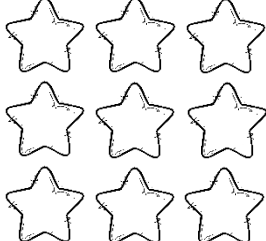
	
<input type="text"/>	<input type="text"/>

Vul in: meer of minder

35 is _____ as 38	28 is _____ as 82	4 is _____ as 3
9 is _____ as 6	79 is _____ as 65	32 is _____ as 52
40 is _____ as 45	19 is _____ as 91	4 is _____ as 7

# Meer as en minder as in die woestyn

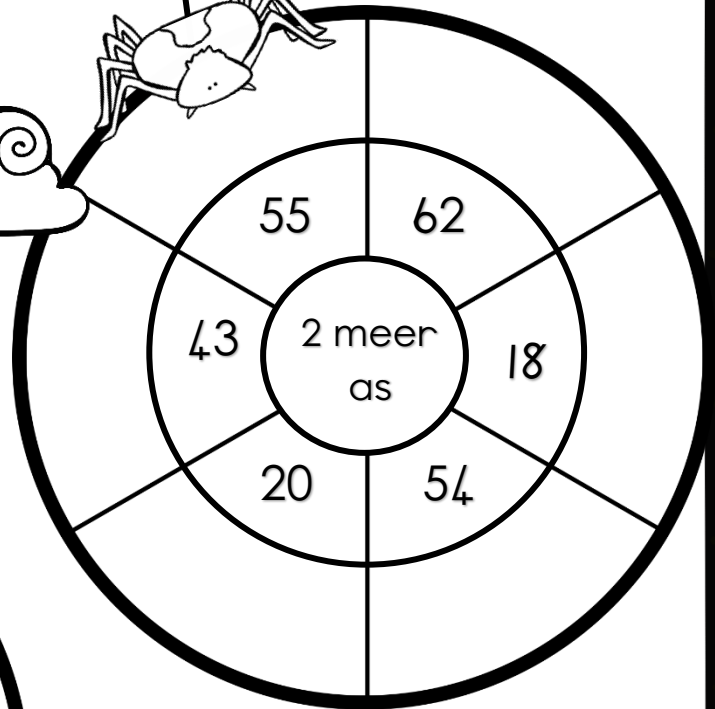
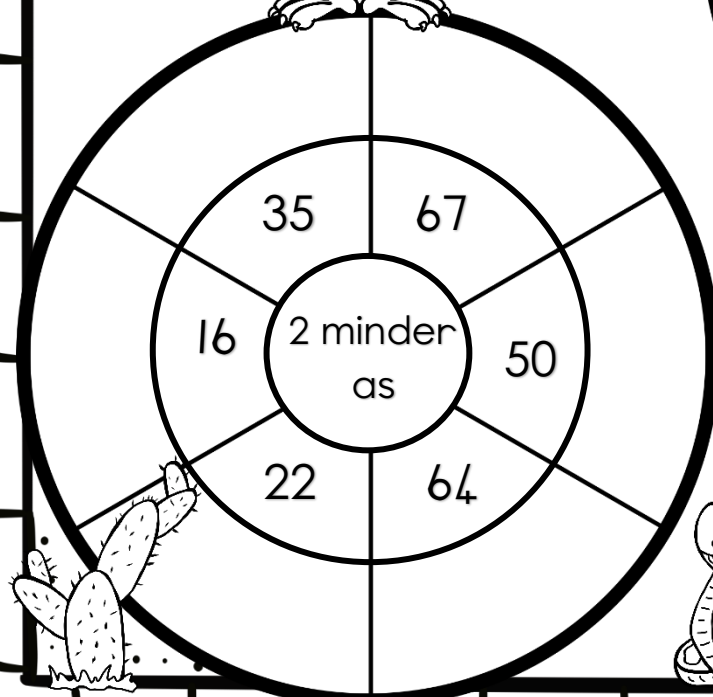
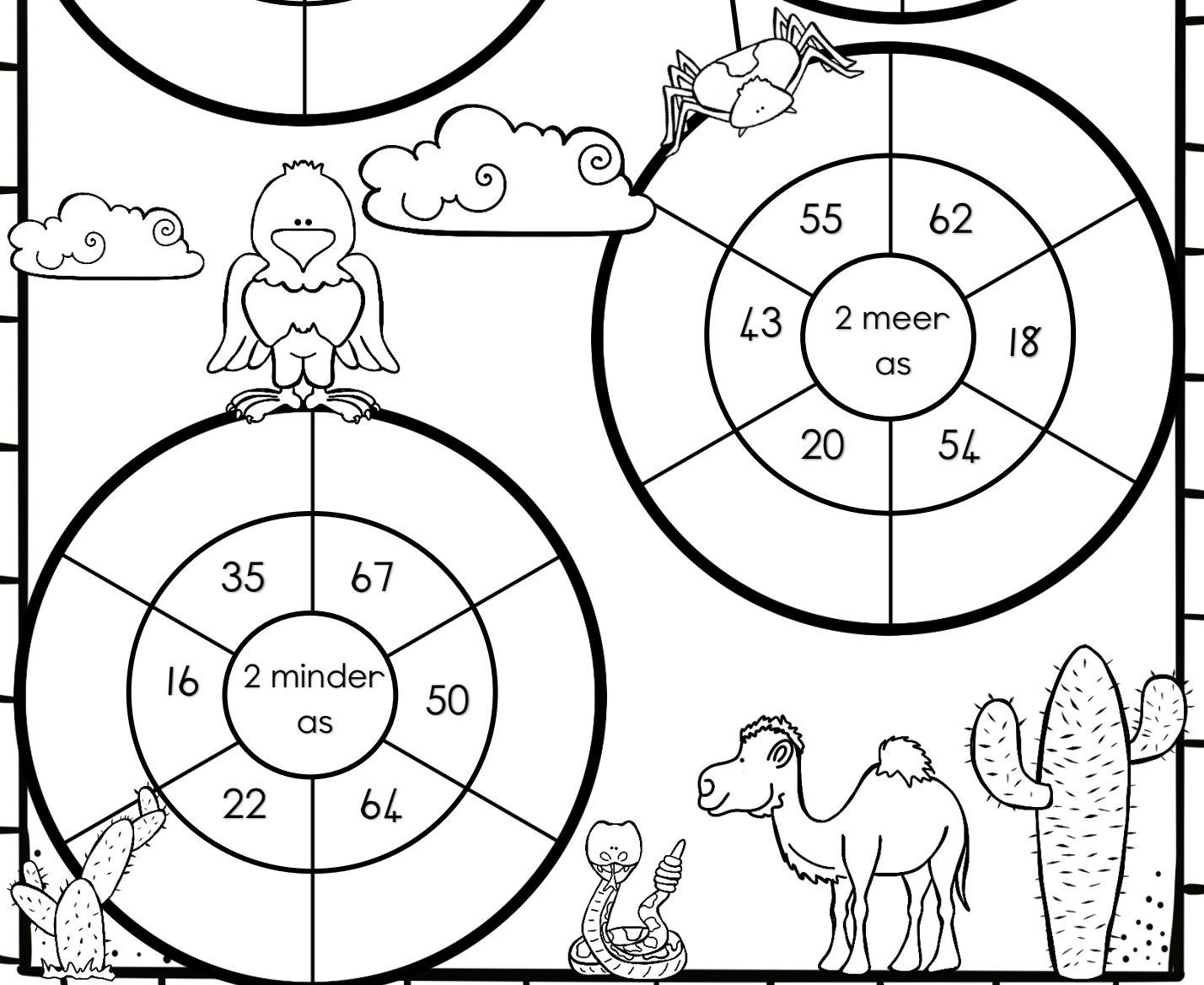
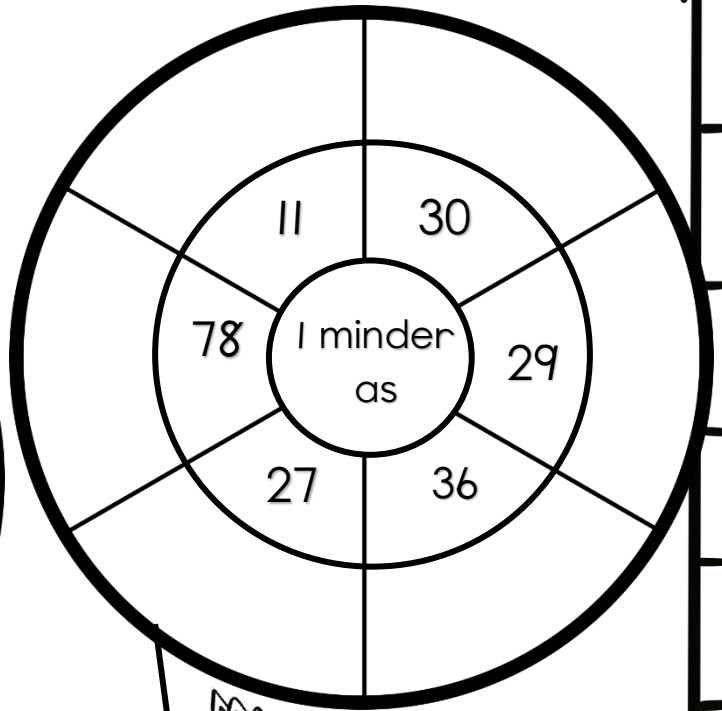
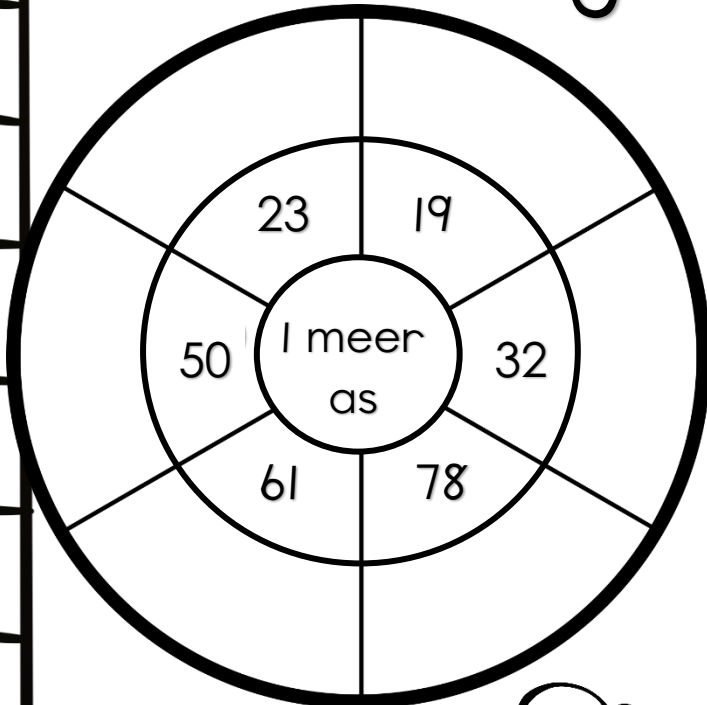

Voor, tussen  
en na

voor tussen na

16

17

18



Skryf watter getal kom voor, tussen en na.

Voor	Tussen	Na
2		4
	17	
8		10
33	34	
	9	
14		16
0	1	
24	25	
17		19
19		21
17	18	
	6	
16	17	

Voor	Tussen	Na
35		37
	12	
1		3
28	29	
	14	
	11	12
	20	21
30		32
	1	2
7		9
	28	29
38	39	
	30	31

# Ranggetalle

Oefen om die ranggetalle te skryf.

1ste	eerste	eerste	
2de	tweede	tweede	
3de	derde	derde	
4de	vierde	vierde	
5de	vyfde	vyfde	
6de	sesde	sesde	
7de	sewende	sewende	
8ste	agttste	agttste	
9de	negende	negende	
10de	tiende	tiende	



# Ranggetalle



1ste



2de



3de



4de



5de



6de



7de



8ste













9de



10de

Kyk na die volgorde van die prente hierbo en beantwoord die vrae.

Die  is	
Die  is	
Die  is	
Die  is	
Die  is	
Die  is	
Die  is	
Die  is	
Die  is	
Die  is	

# 2D vorms

Trek die vorms na.  
Oefen om die name van die vorms te skryf.

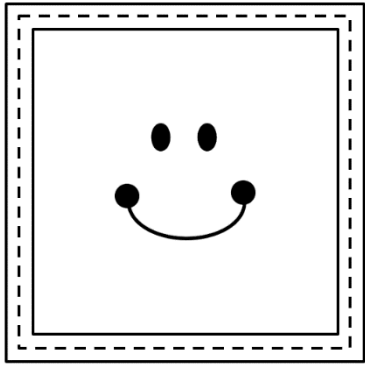

vierkant

---

---

---

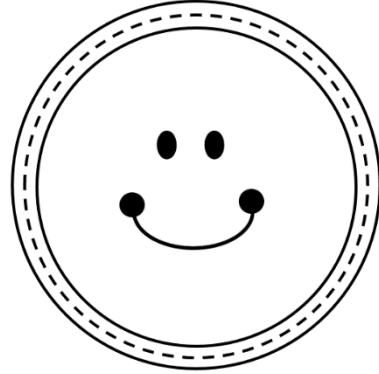

sirkel

---

---

---

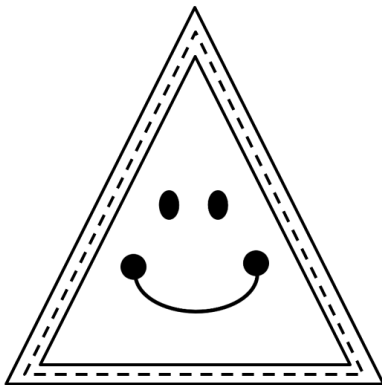

driehoek

---

---

---

# 2D vorms

Tel die vorms in die prent.

Kleur die vorms op die volgende maniere in:

- driehoek – geel
- vierkant – blou
- sirkel - groen

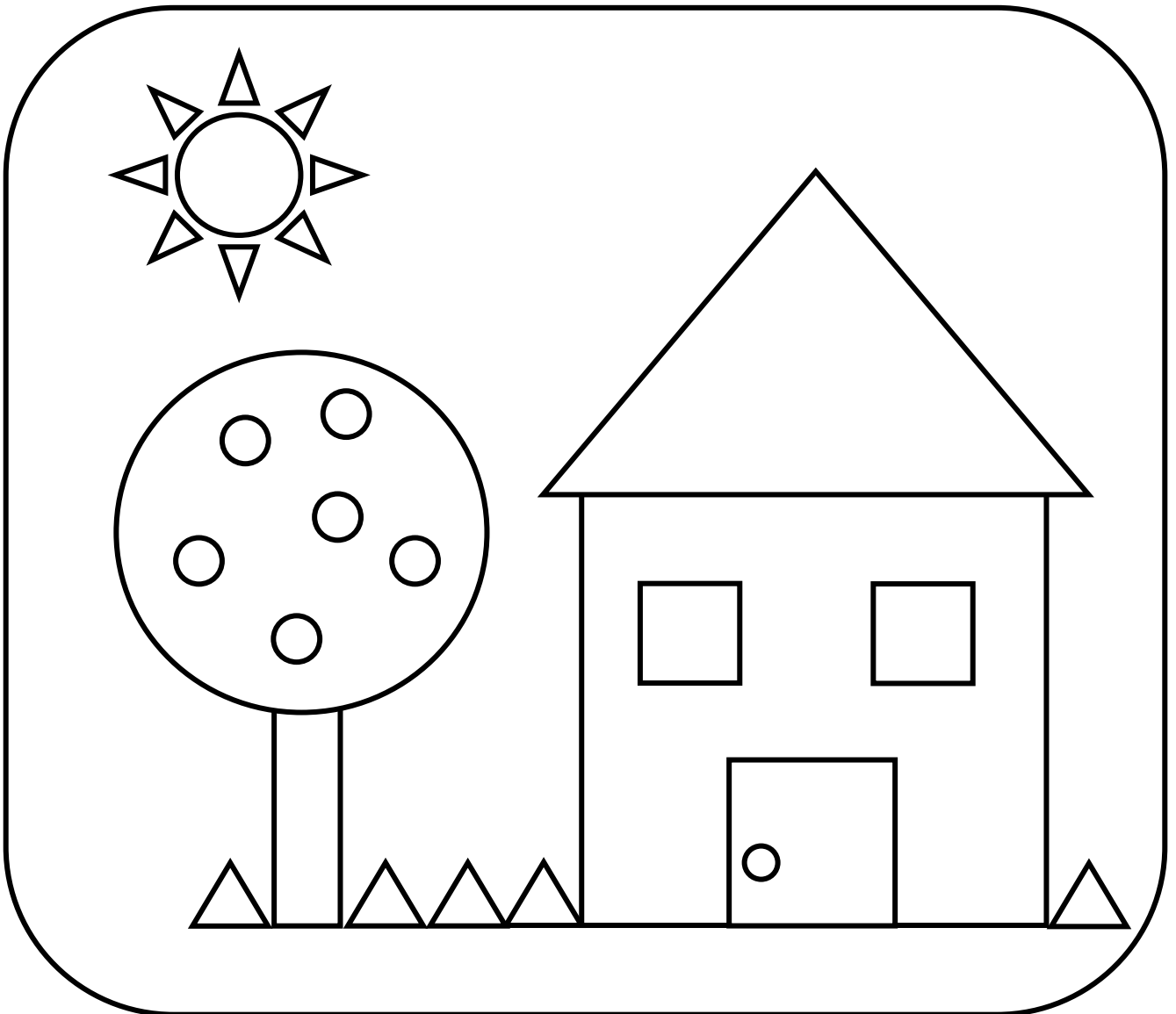

Hoeveel vorms tel jy?

sirkels  vierkante  driehoeke

# 2D vorms – reguit en ronde sye

reguit sy

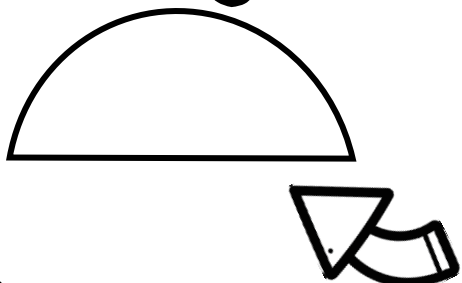

ronde sy

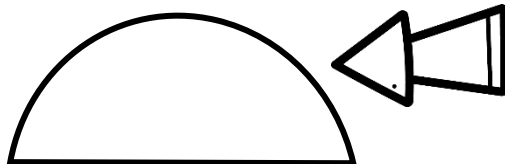

Kleur die vorms op die volgende maniere in:

- vorms met reguit sye – pers
- vorms met ronde sye – geel

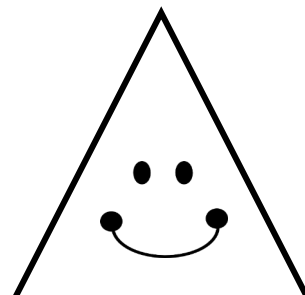
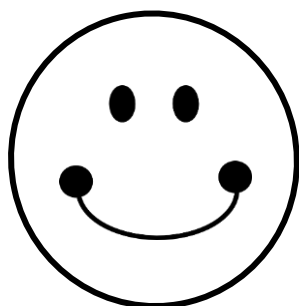
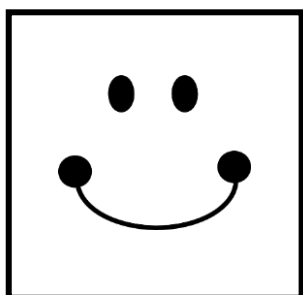

Teken 'n vorm met:

reguit sye

ronde sye

# Simmetrie

'n Simmetrielyn verdeel 'n vorm in twee halwes sodat elke halwe 'n spieëlbeeld van die ander is.

'n Vorm is simmetries indien jy dit met die simmetrielyn langs kan vou en die twee helftes presies dieselfde is.

Teken 'n simmetrielyn vir die volgende vorms en prente.

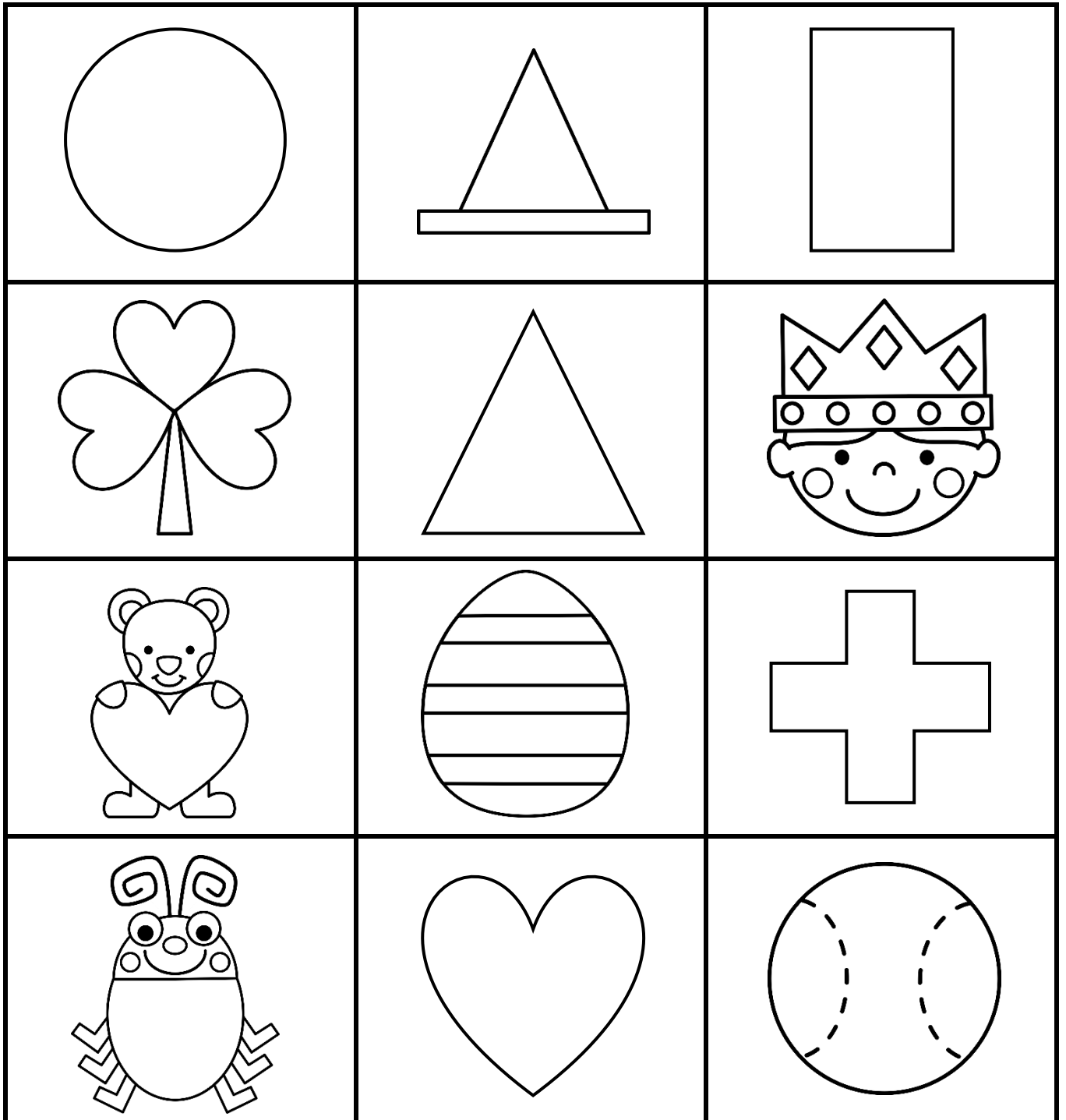

# Simmetrie

- Knip die prente op die volgende bladsy uit.
- Vou dan die prent presies in die helfte sodat albei kante dieselfde lyk.
- Trek 'n stippellyn met 'n kleurpotlood en liniaal op die lyn waar die prent gevou is.
- Plak dan die prente in die blokke hieronder.

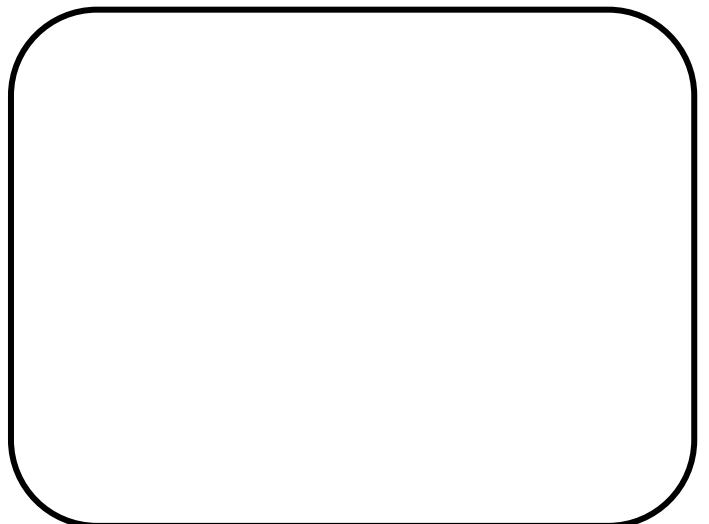
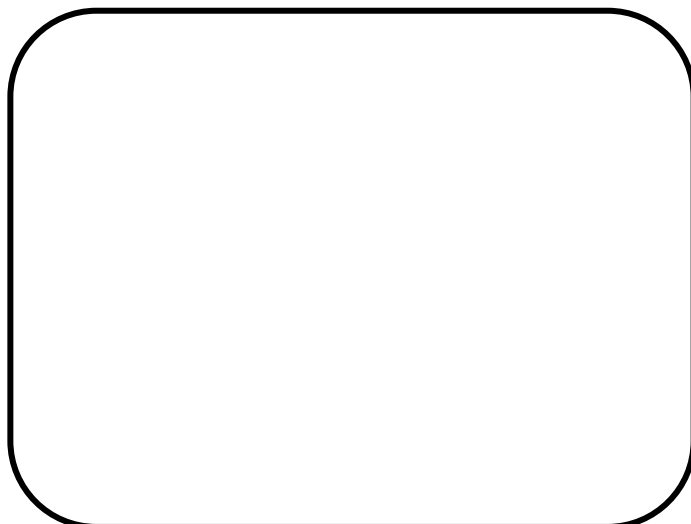
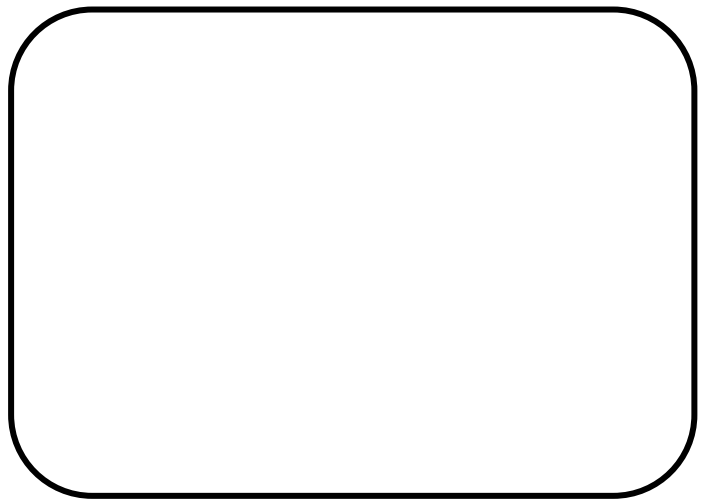

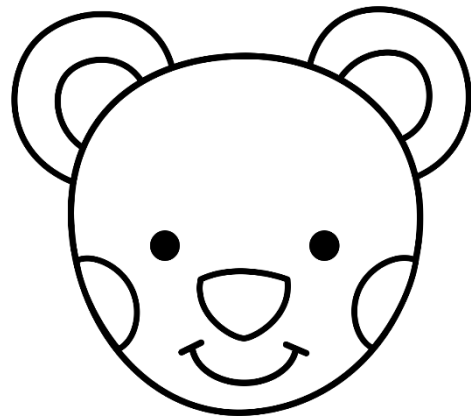
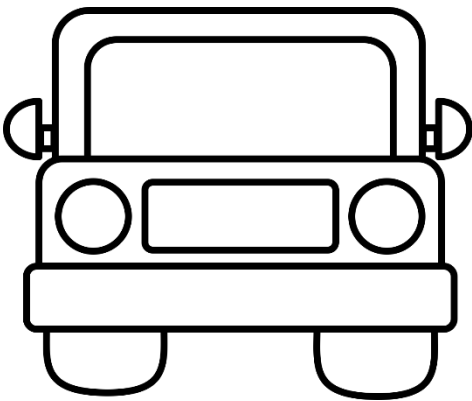
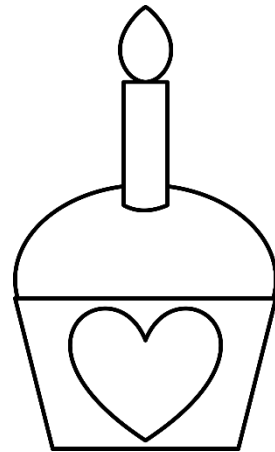
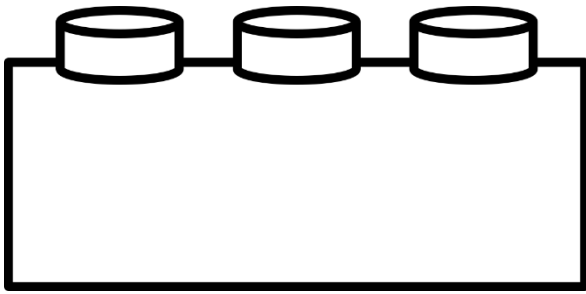
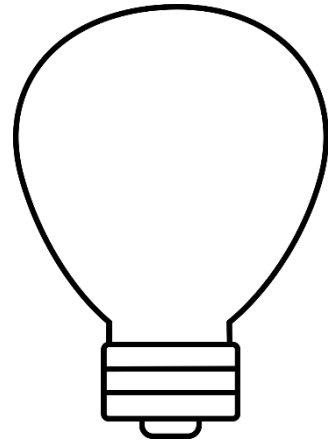
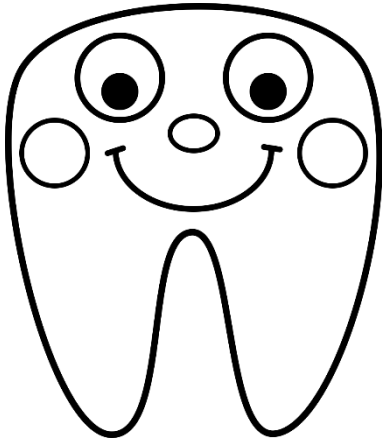

# Simmetrie

Teken die ander helfte van die prente.

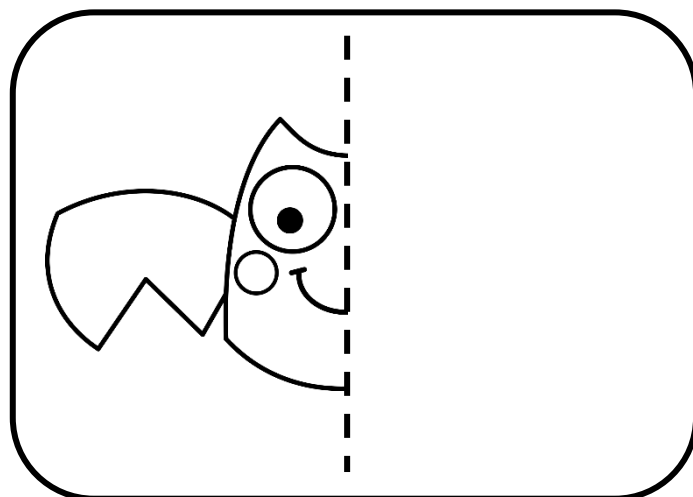
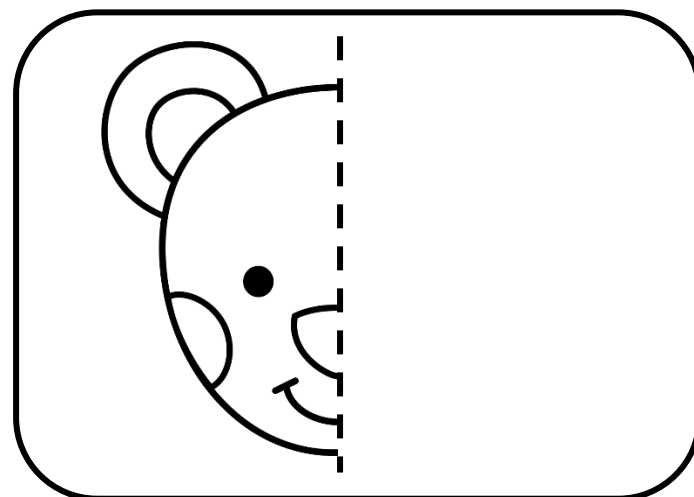
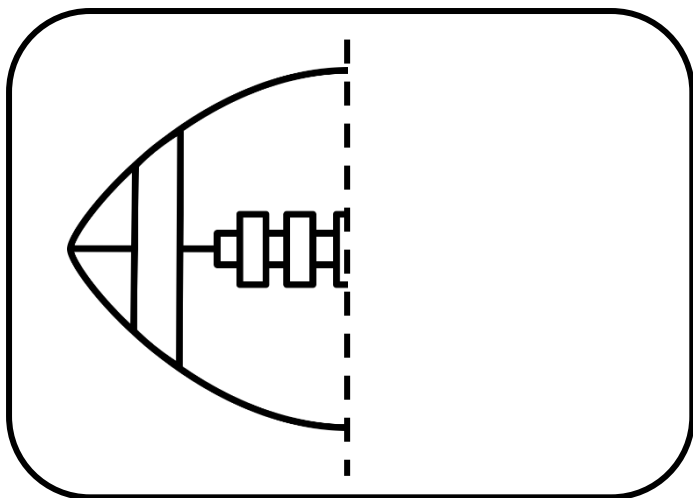
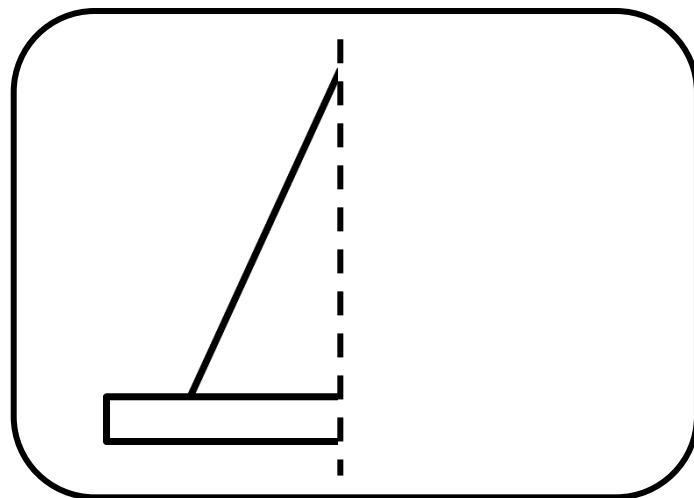
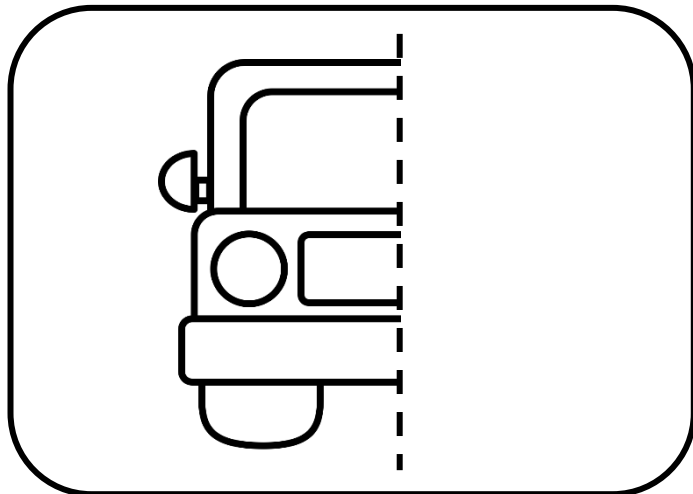
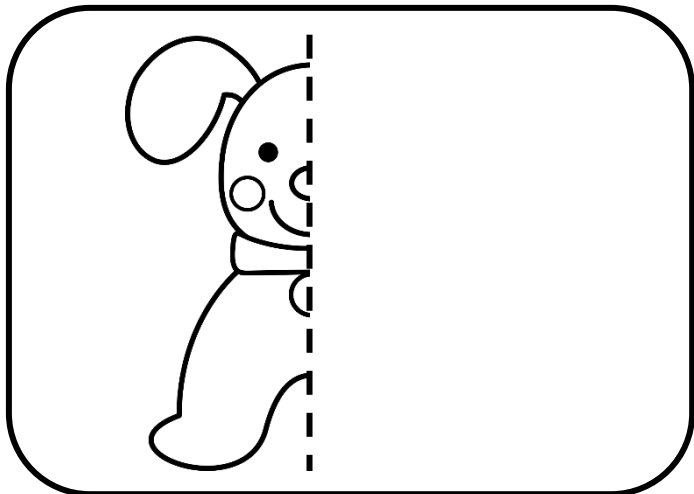



# 3D-voorwerpe

Oef en die woorde.

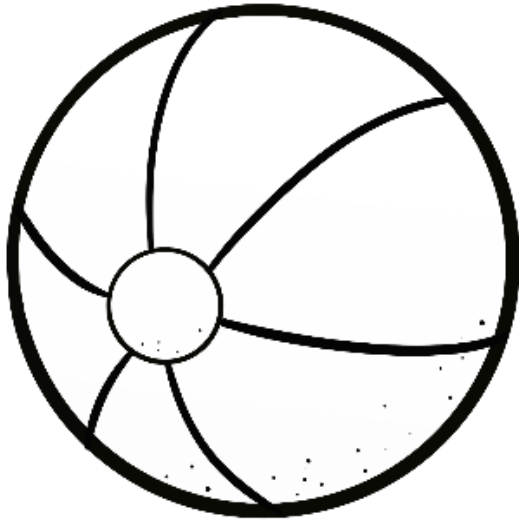

bebe

bebe

\_\_\_\_\_

-----

\_\_\_\_\_

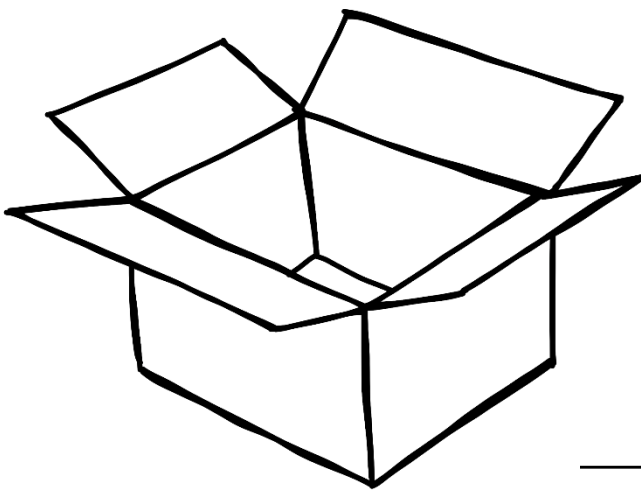

boxe

boxe

\_\_\_\_\_

-----

\_\_\_\_\_

# 3D-voorwerpe

Kleur die 3D-voorwerpe op die volgende maniere in:

Voorwerpe wat kan gly

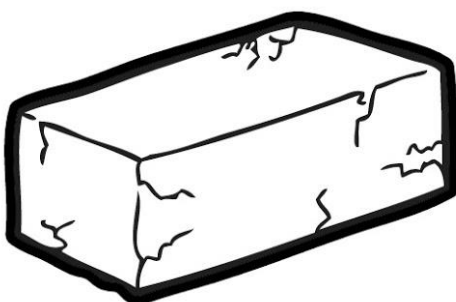
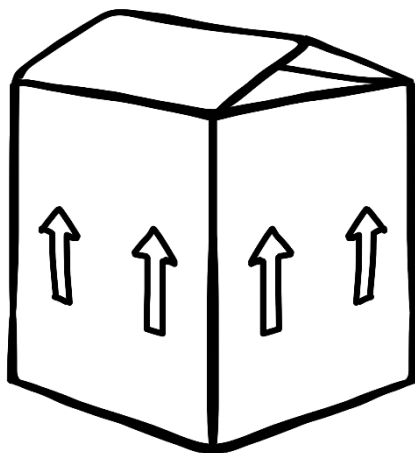
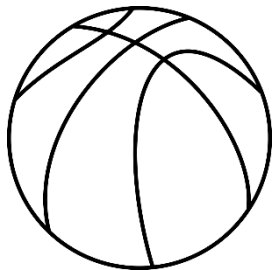
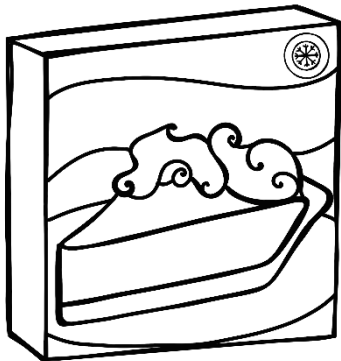
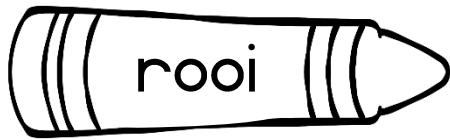

Voorwerpe wat kan rol

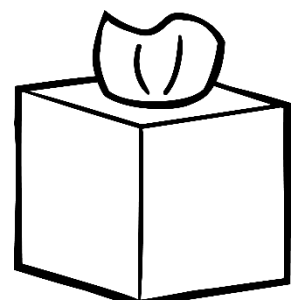
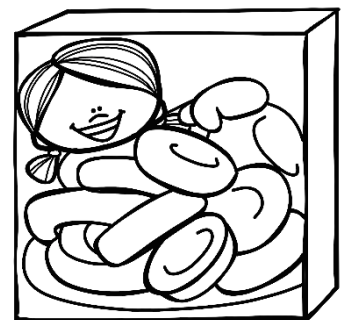
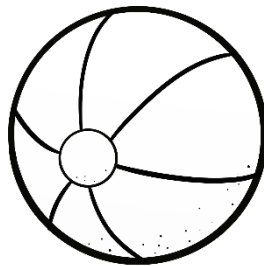
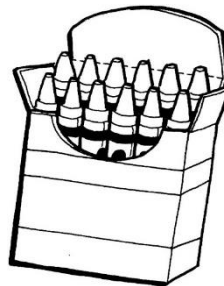
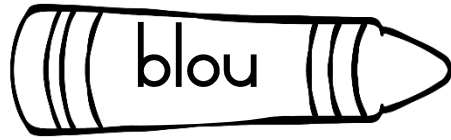

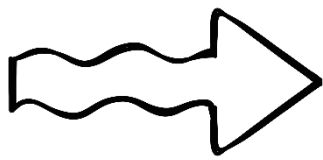

# Geld

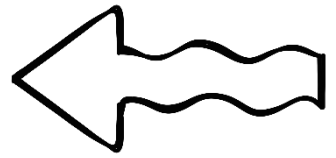





Benoem die geld.

5c, 10c, 20c, 50c, R1, R2, R5, R10 en R20

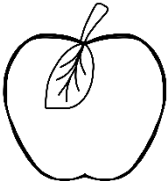

# Geld

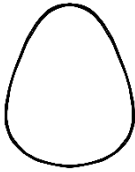
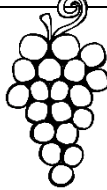
Bereken hoeveel dit sal kos. Hoeveel kleingeld sal hulle kry?

					
R5	R3	R2	R5	R10	R9

Klara betaal met R10.

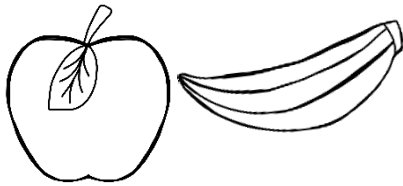

Wat sal dit kos?

$$\underline{\quad} + \underline{\quad} = \underline{\quad}$$

Wat is die verskil?

$$\underline{\quad} - \underline{\quad} = \underline{\quad}$$

Klara sal        kleingeld kry.

Jana betaal met R20.



Wat sal dit kos?

$$\underline{\quad} + \underline{\quad} = \underline{\quad}$$

Wat is die verskil?

$$\underline{\quad} - \underline{\quad} = \underline{\quad}$$

Jana sal        kleingeld kry.

Hendrik betaal met R15.



Wat sal dit kos?

$$\underline{\quad} + \underline{\quad} = \underline{\quad}$$

Wat is die verskil?

$$\underline{\quad} - \underline{\quad} = \underline{\quad}$$

Hendrik sal        kleingeld kry.

Jan betaal met R20.

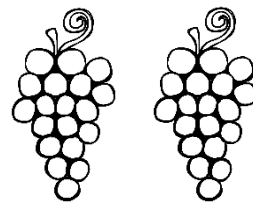

Wat sal dit kos?

$$\underline{\quad} + \underline{\quad} = \underline{\quad}$$

Wat is die verskil?

$$\underline{\quad} - \underline{\quad} = \underline{\quad}$$

Jan sal        kleingeld kry.

# Probleemoplossing

- Geld -

Lees die woordprobleme. Gebruik die getallelyn om jou antwoord te wys. Skryf 'n getalsin vir elkeen.

Dit was Sondag Judy se verjaarsdag. Sy ontvang R5 by haar suster, R2 by haar broer en R10 by haar niggie. Hoeveel geld het sy altesaam gekry?

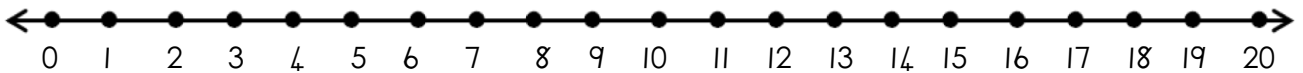

Getalsin: \_\_\_\_\_



Jan het 'n brood van R8 gekoop. Hy betaal met 'n R10-noot. Hoeveel kleingeld het hy gekry?

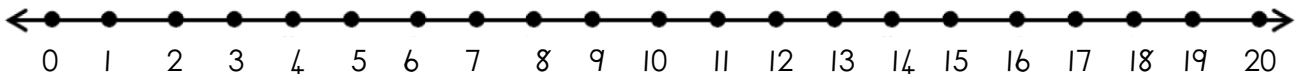

Getalsin: \_\_\_\_\_

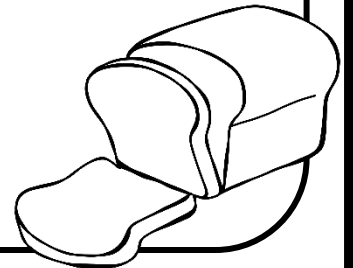

Rosie se ma het 'n serp van R17 gekoop. Sy betaal met 2 tien randnote. Hoeveel kleingeld het sy gekry?

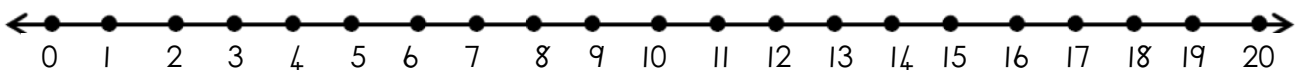

Getalsin: \_\_\_\_\_

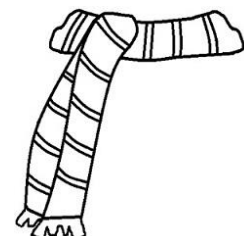







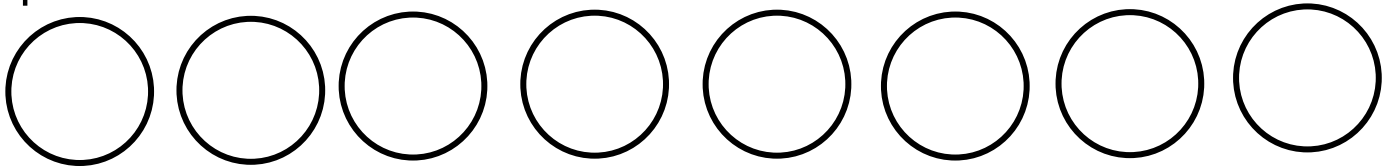

# Meetkundige patrone

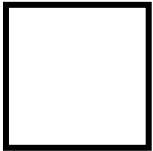
Kleur die sirkels in met verskillende kleure sodat dit 'n patroon vorm:

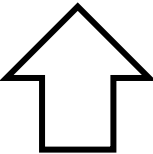
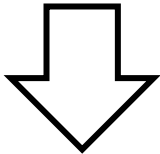
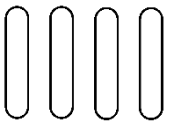
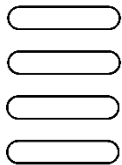

Voltooi die patroon deur die volgende vorms te teken.

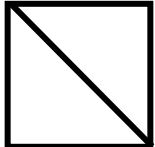
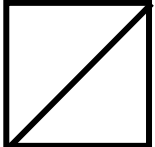
# Meetkundige patrone

Voltooi die patrone.

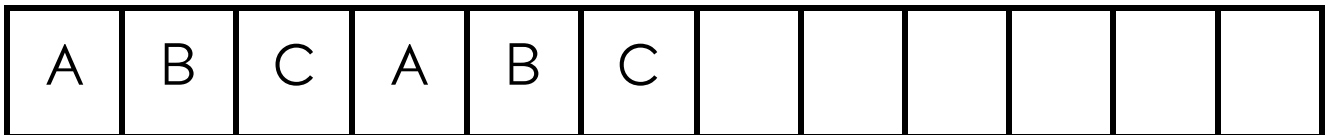
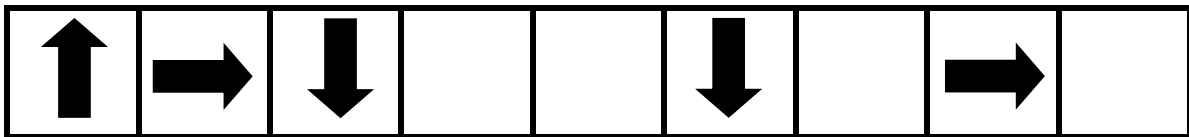
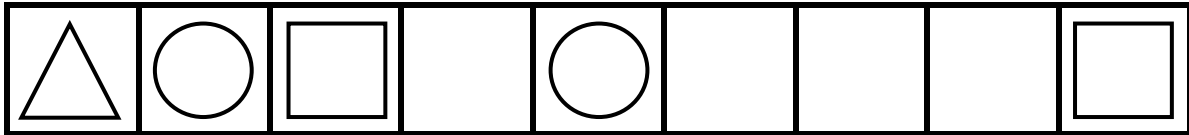
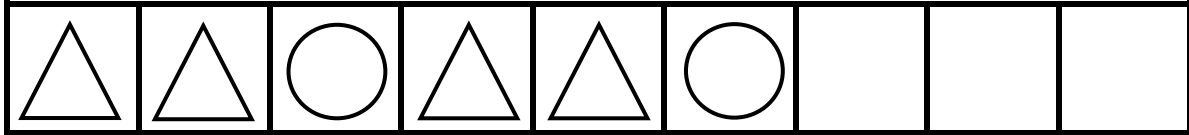

Maak jou eie patroon deur driehoeke, sirkels of vierkante te gebruik. Gebruik verskillende kleure.



# Aansigte

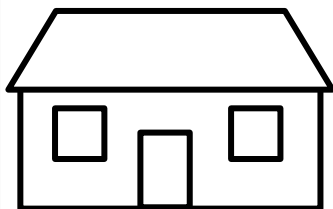

vooraansig

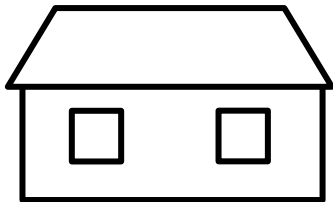

agteraansig

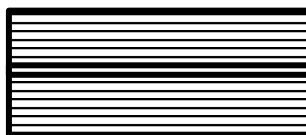

bo-aansig



syaansig

Kleur die regte aansig van die huis in.

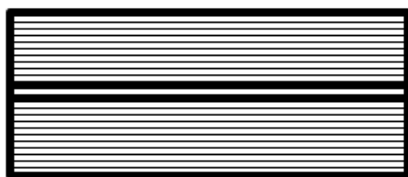
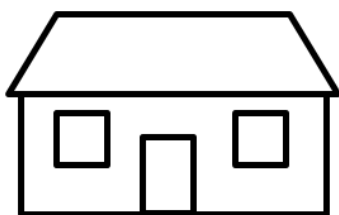

vooraansig

bo-aansig

syaansig

vooraansig

bo-aansig

syaansig

vooraansig

bo-aansig

syaansig

voor

bo

sy



# Waar is die muis?

Gebruik die woorde in die blokke.

voor

agter

langs

bo-op

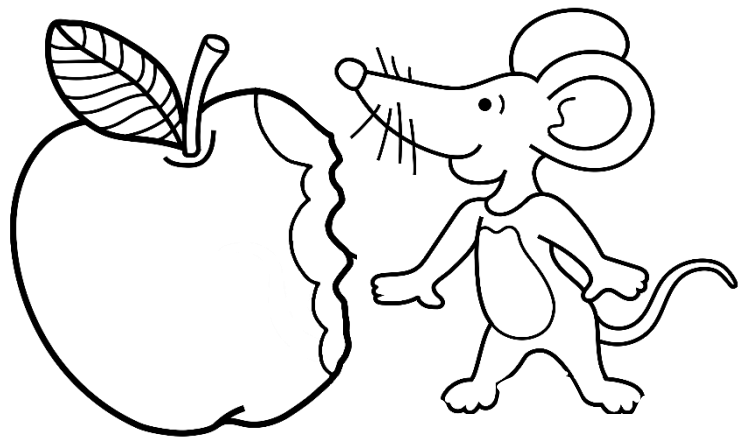
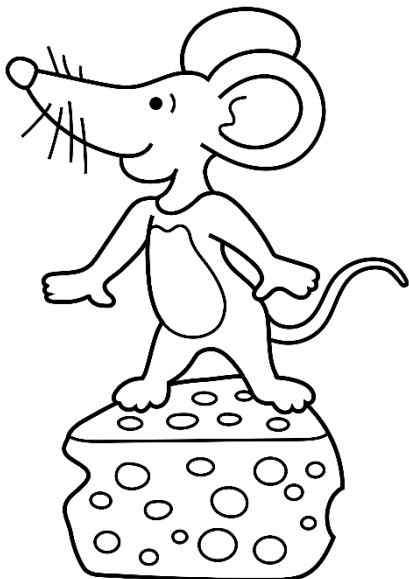
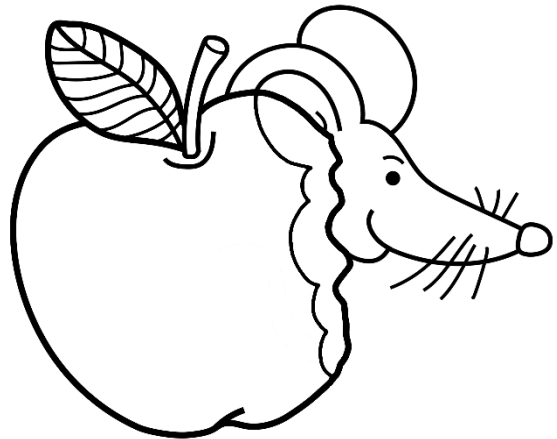
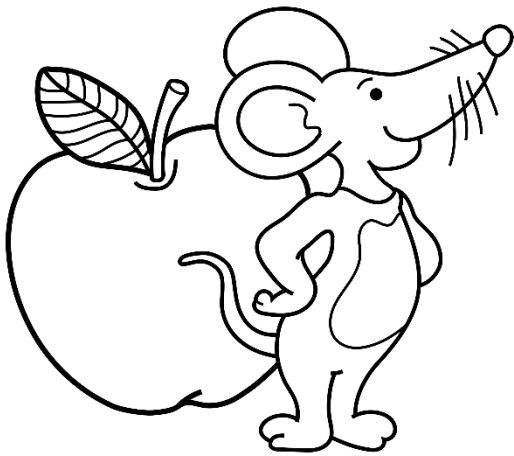

# Verdubbel

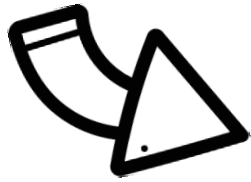

$3 + 3 = 6$

Verdubbel die besies en teken dit op die leë blaar.

Verdubbel 4

\_\_\_\_\_ + \_\_\_\_\_ = \_\_\_\_\_

Verdubbel 7

\_\_\_\_\_ + \_\_\_\_\_ = \_\_\_\_\_

Verdubbel 6

\_\_\_\_\_ + \_\_\_\_\_ = \_\_\_\_\_

Verdubbel 10

\_\_\_\_\_ + \_\_\_\_\_ = \_\_\_\_\_

Verdubbel 5

\_\_\_\_\_ + \_\_\_\_\_ = \_\_\_\_\_

Verdubbel 8

\_\_\_\_\_ + \_\_\_\_\_ = \_\_\_\_\_

# Halveer

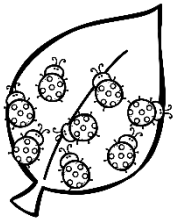
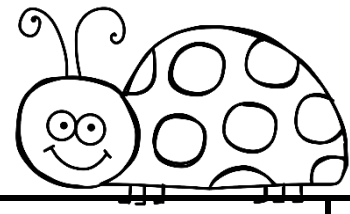

Die helfte van 8 is

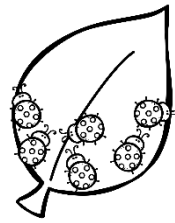

Die helfte van 6 is

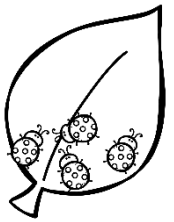

Die helfte van 4 is

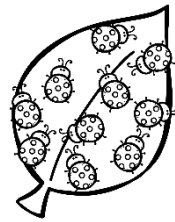

Die helfte van 10 is

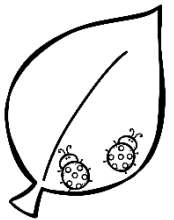

Die helfte van 2 is

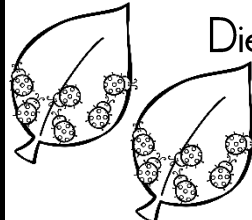

Die helfte van 12 is

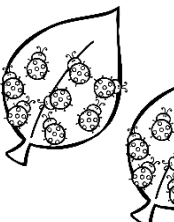

Die helfte van 16 is

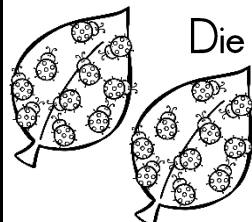

Die helfte van 20 is

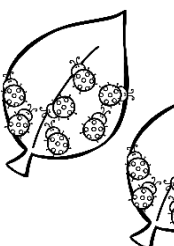

Die helfte van 18 is

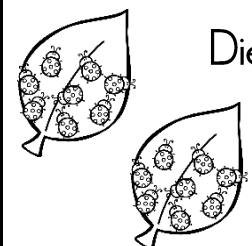



# Deling

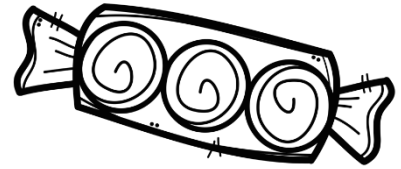

Deel die lekkers gelykop tussen die kinders sodat almal eweveel kry.

4 lekkers

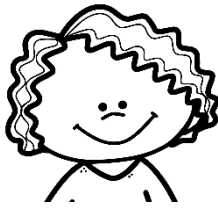

Hoeveel lekkers kry elkeen? \_\_\_\_\_

6 lekkers



Hoeveel lekkers kry elkeen? \_\_\_\_\_

9 lekkers

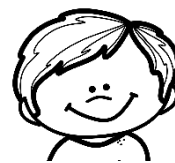

Hoeveel lekkers kry elkeen? \_\_\_\_\_

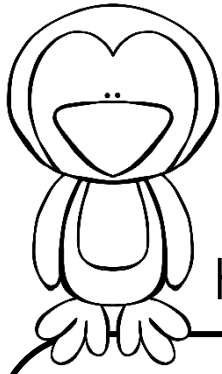

# Deling met 'n res

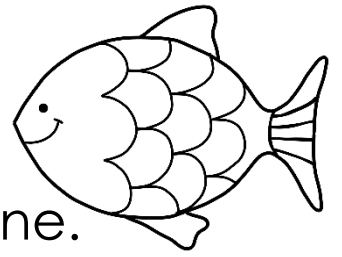

Deel die vis tussen die pikkewyne.  
Hoeveel vis bly oor? Maak 'n tekening.

5 visse



Hoeveel vis bly oor? \_\_\_\_\_

11 visse

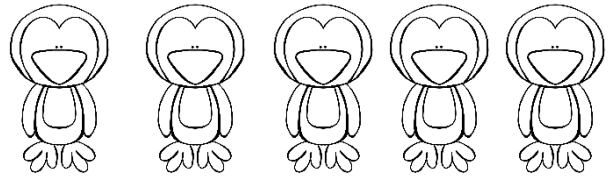

Hoeveel vis bly oor? \_\_\_\_\_

7 visse

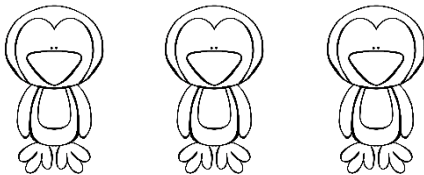

Hoeveel vis bly oor? \_\_\_\_\_

3 visse

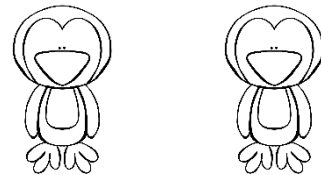

Hoeveel vis bly oor? \_\_\_\_\_

9 visse

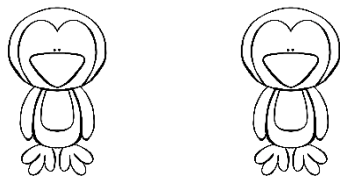

Hoeveel vis bly oor? \_\_\_\_\_

16 visse

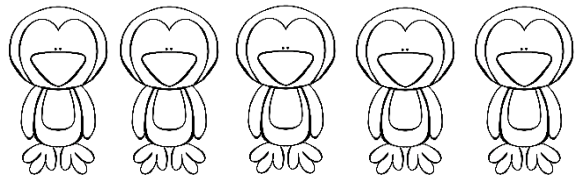

Hoeveel vis bly oor? \_\_\_\_\_

# Massa



Skryf neer hoeveel blokkies op elke kant is.

Kleur die kant in wat swaarder is.

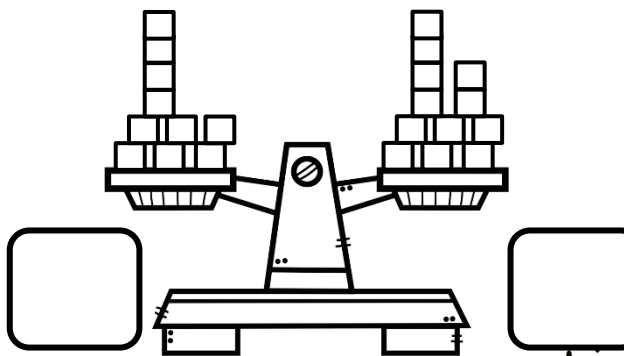
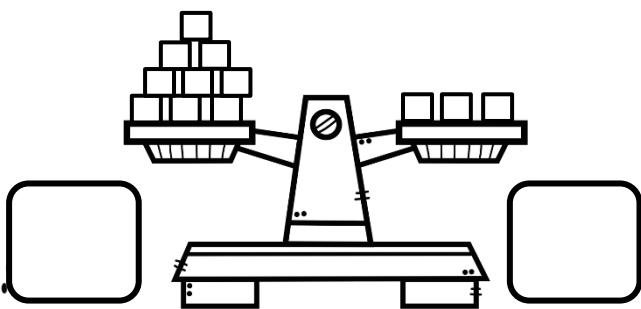
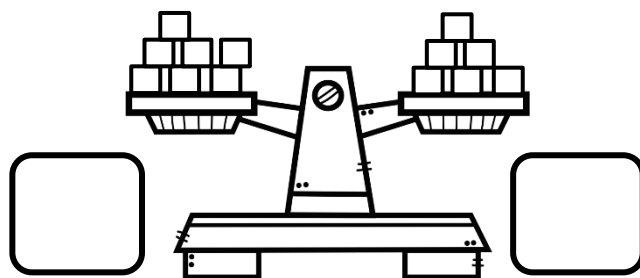
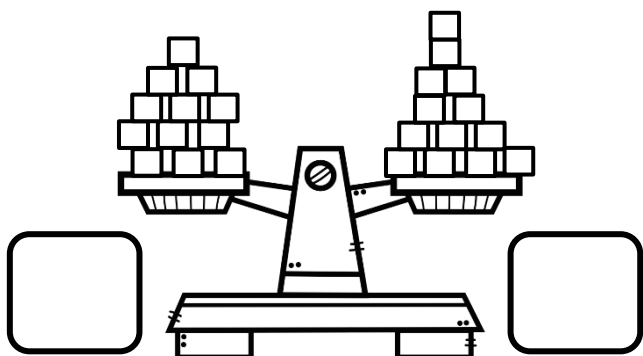
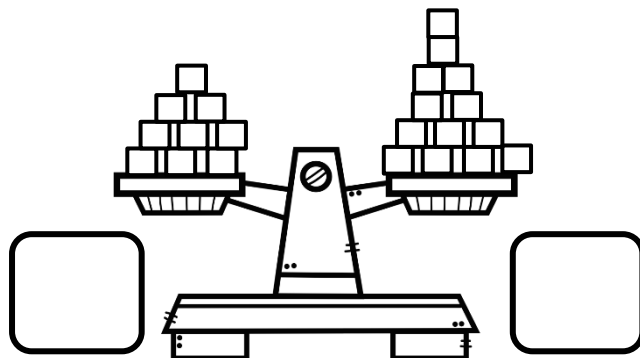
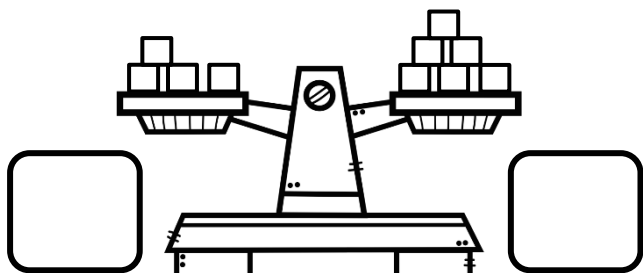
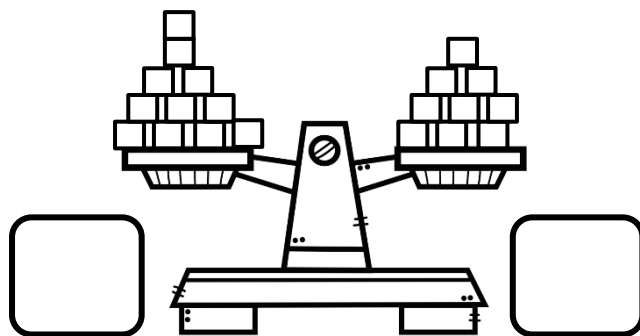
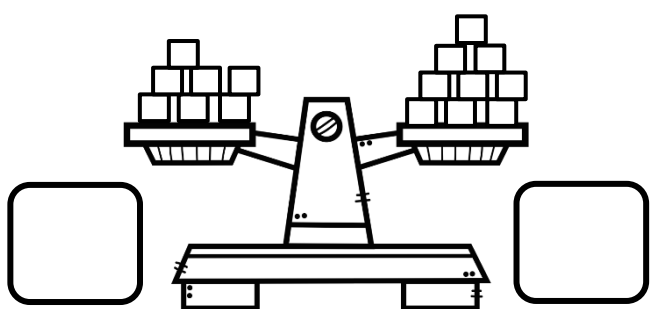

# Massa



Tel hoeveel blokkies daar is. Werk dan uit hoeveel ekstra blokkies nodig is om die voorwerp te balanseer. Ons sê vir jou hoeveel blokkies die voorwerp weeg.

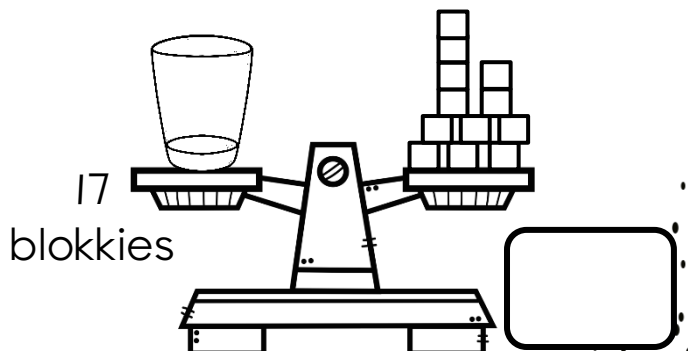
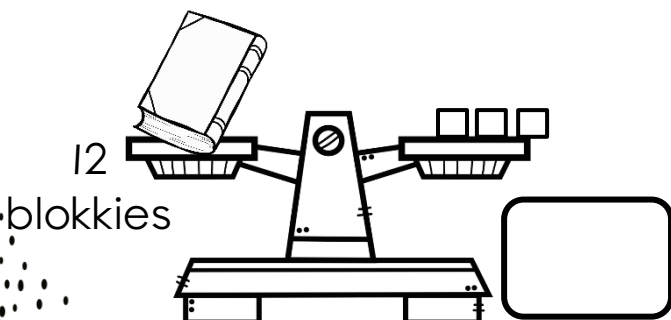
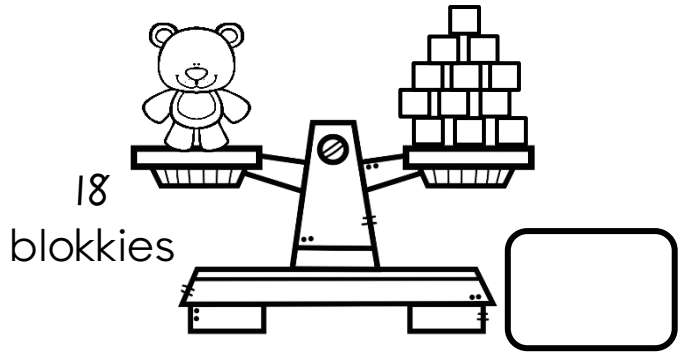
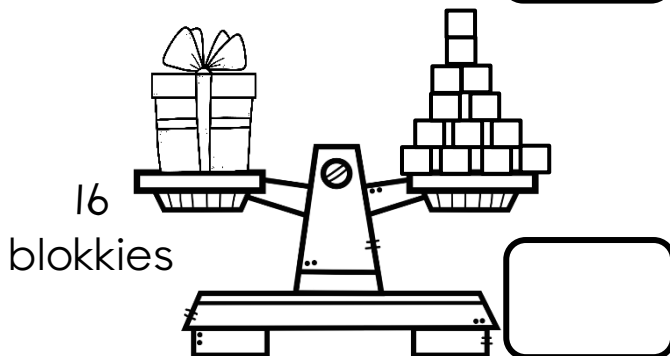
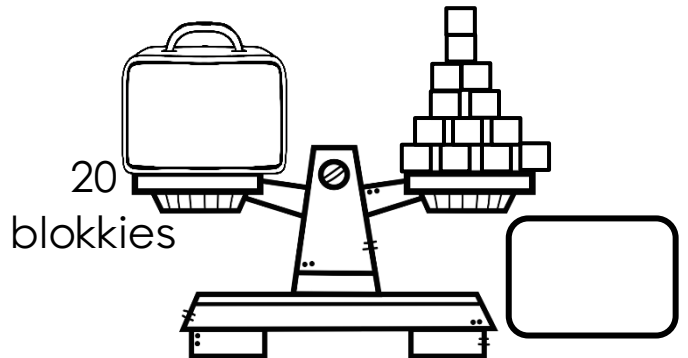
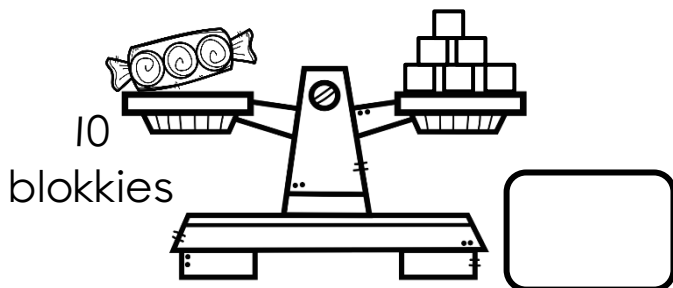
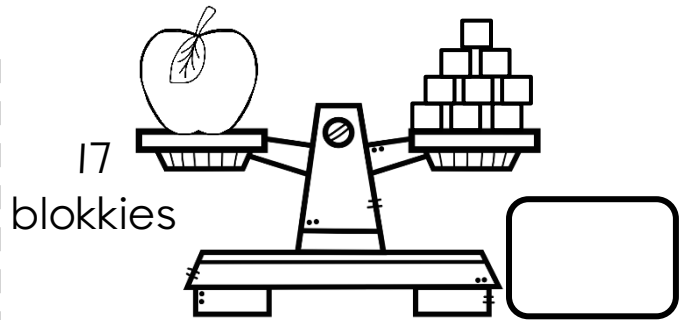
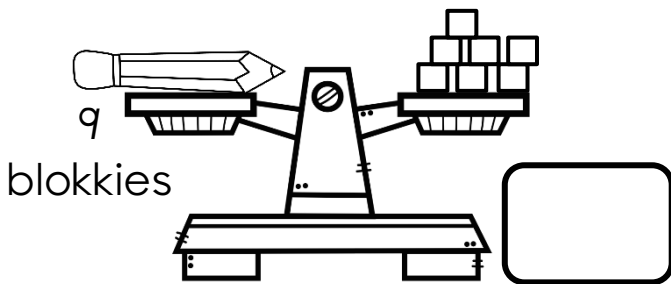

# Kapasiteit

Is die glas vol of leeg? Kleur die regte antwoord in.

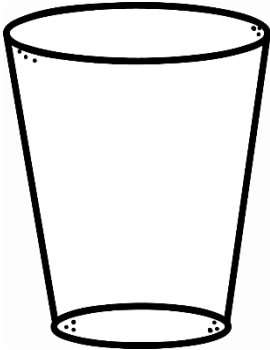

vol

leeg

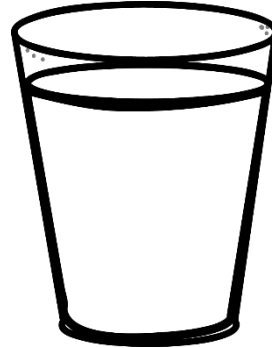

vol

leeg

Kleur die houer in wat die meeste vloeistof sal hou.

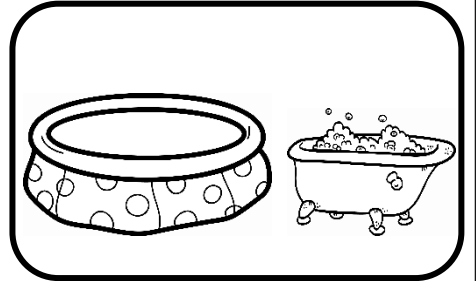
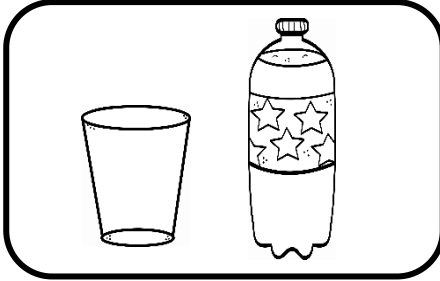
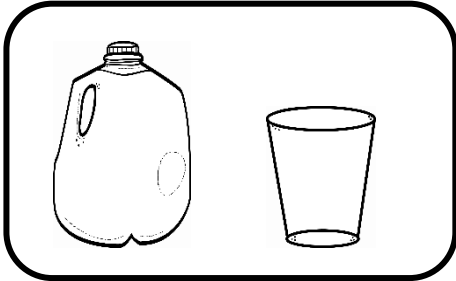
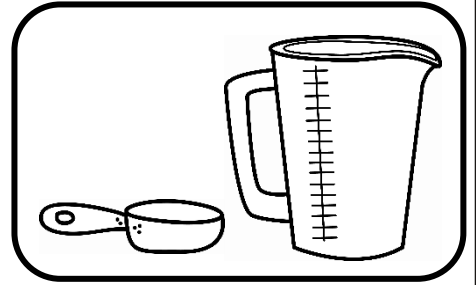
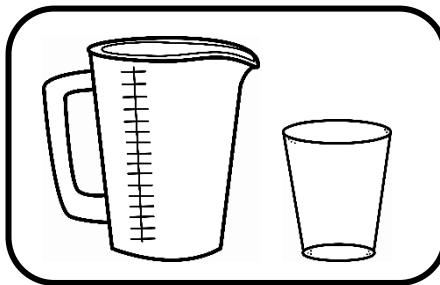
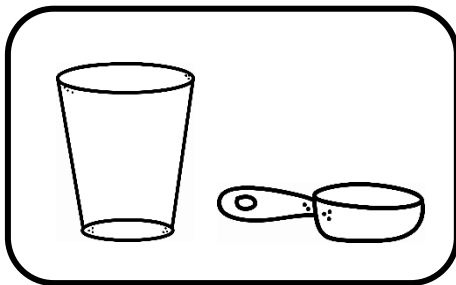

Kleur die houer in wat die minste vloeistof sal hou.

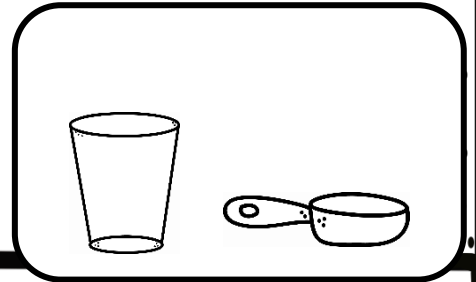
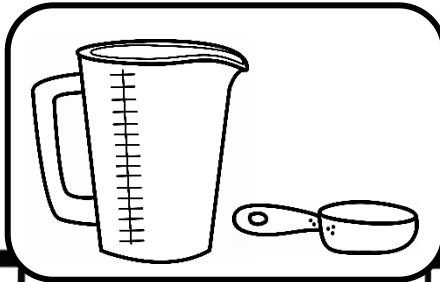
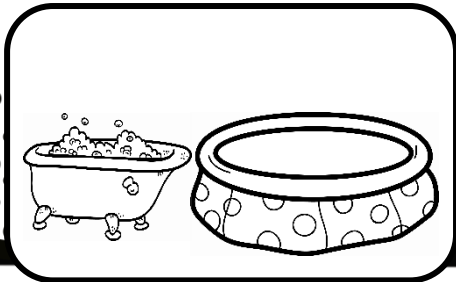
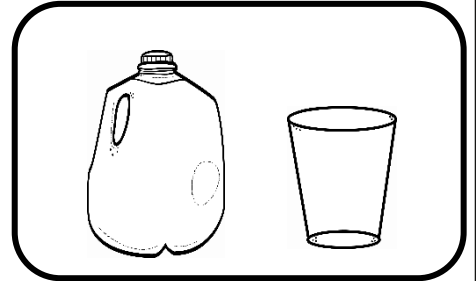
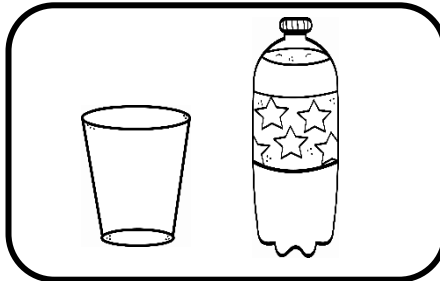
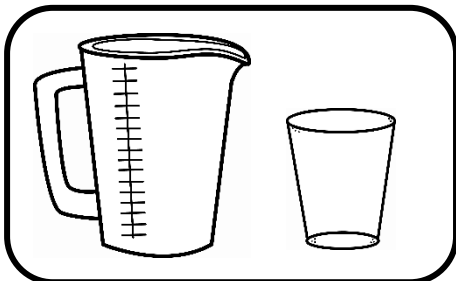



# DATA

Tel die vorms hieronder en kleur dan die blokkies in vir elke vorm.

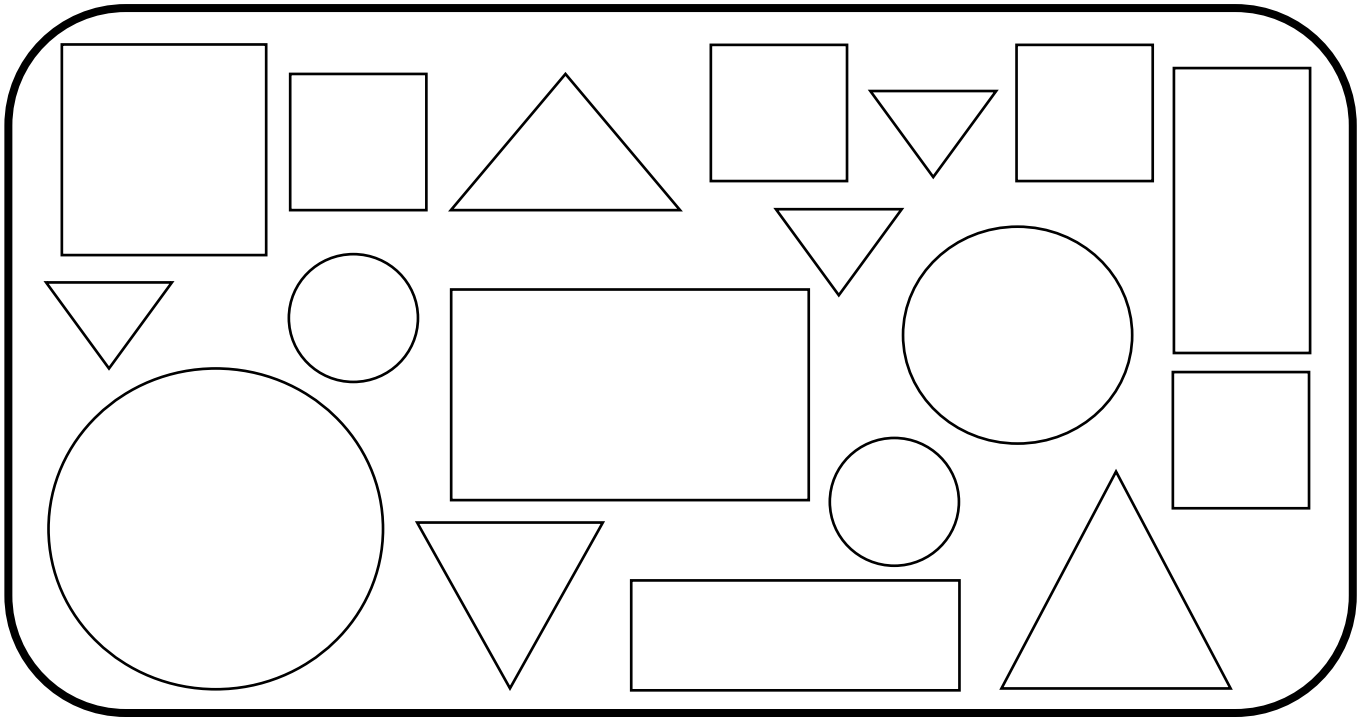

Hoeveel vorms tel jy?

sirkels  vierkante  driehoeke  reghoeke

7				
6				
5				
4				
3				
2				
1				
0				
	sirkel	vierkant	reghoek	driehoek

# DATA met seediere

Juffrou het 'n grafiek gemaak om te wys van watter vrugte die leerdere in die klas hou. Beantwoord die vrae oor die grafiek.

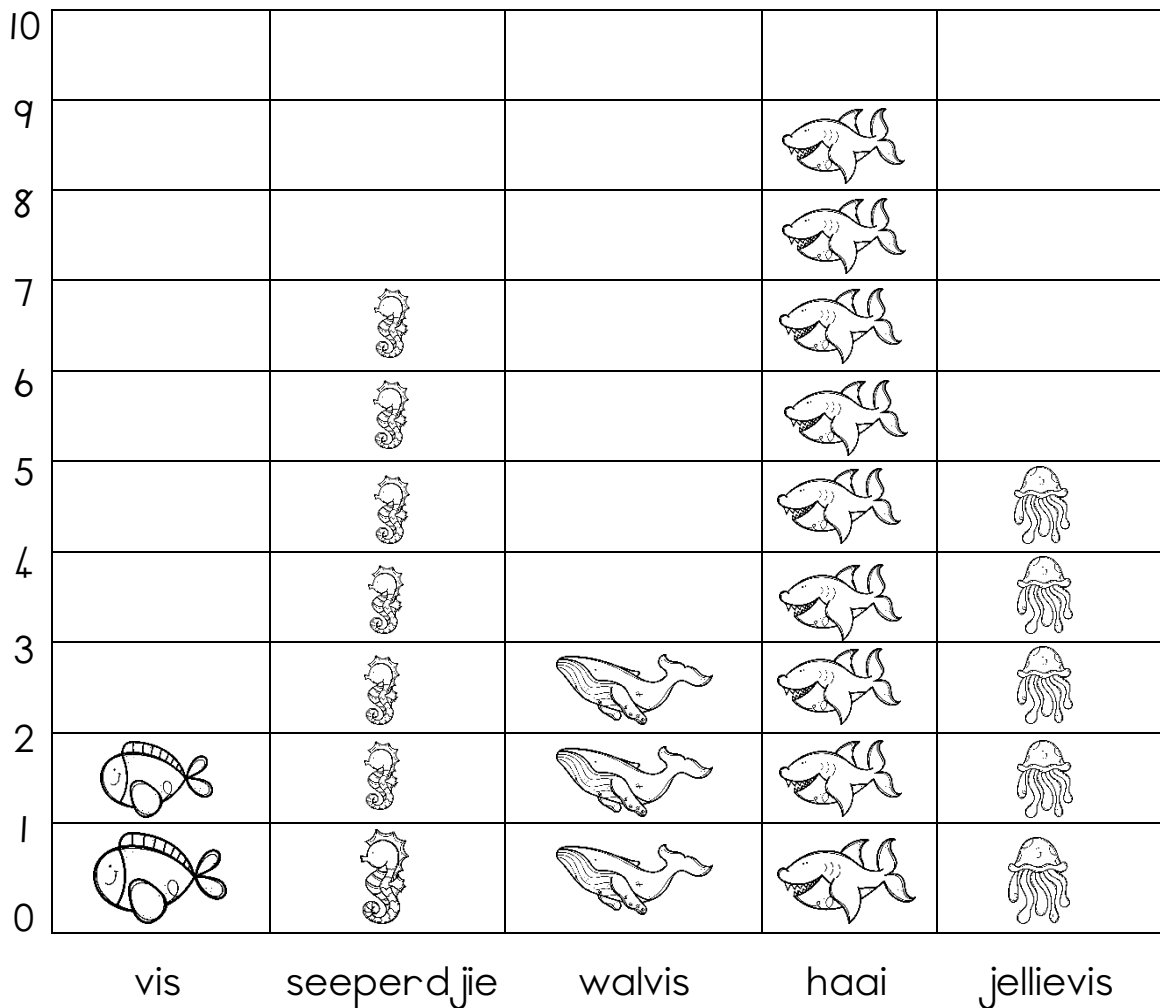

Hoeveel kindere hou van 'n vis? \_\_\_\_\_

Hoeveel kindere hou van 'n seeperdjie? \_\_\_\_\_

Hoeveel kindere hou van 'n walvis? \_\_\_\_\_

Hoeveel kindere hou van 'n haai? \_\_\_\_\_

Hoeveel kindere hou van 'n jellievis? \_\_\_\_\_

Van watter seedier hou die kindere die **meeste**? \_\_\_\_\_

Van watter seedier hou die kindere die **minste**? \_\_\_\_\_