

3 - 4 years

Fun Packet

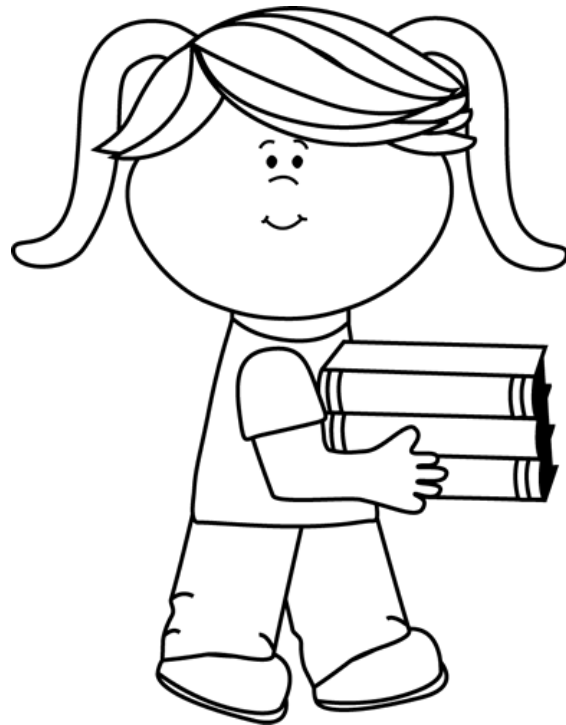

Name:

Help the turtle to
cut on the lines

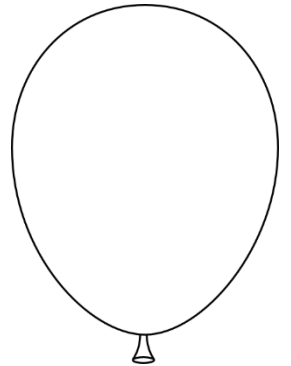
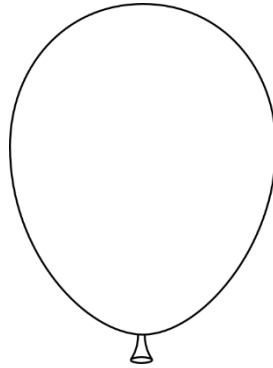
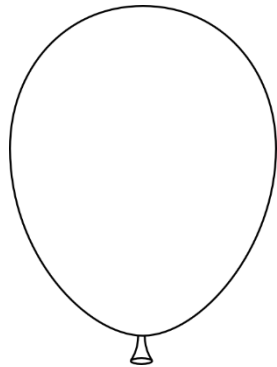
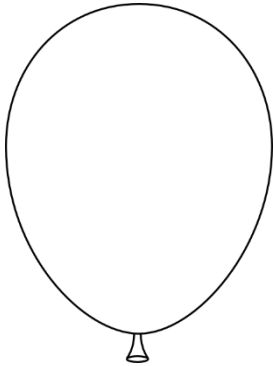
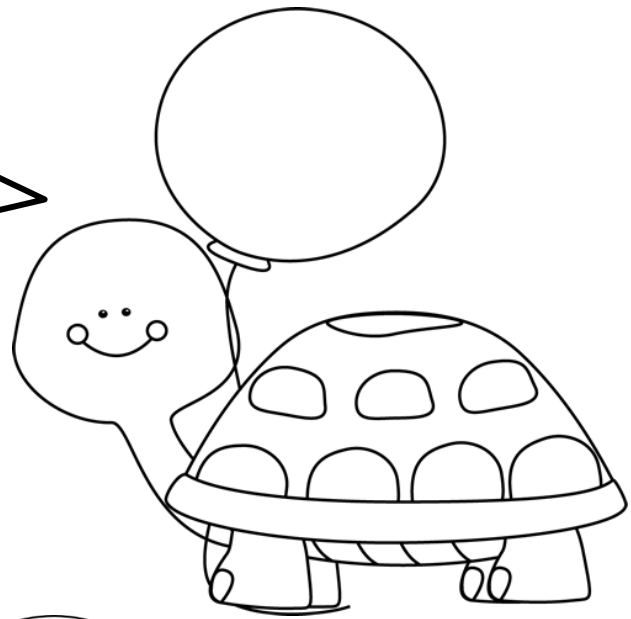

Let's cut!

Cut the square out

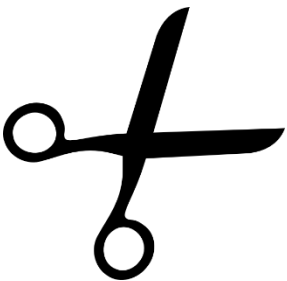
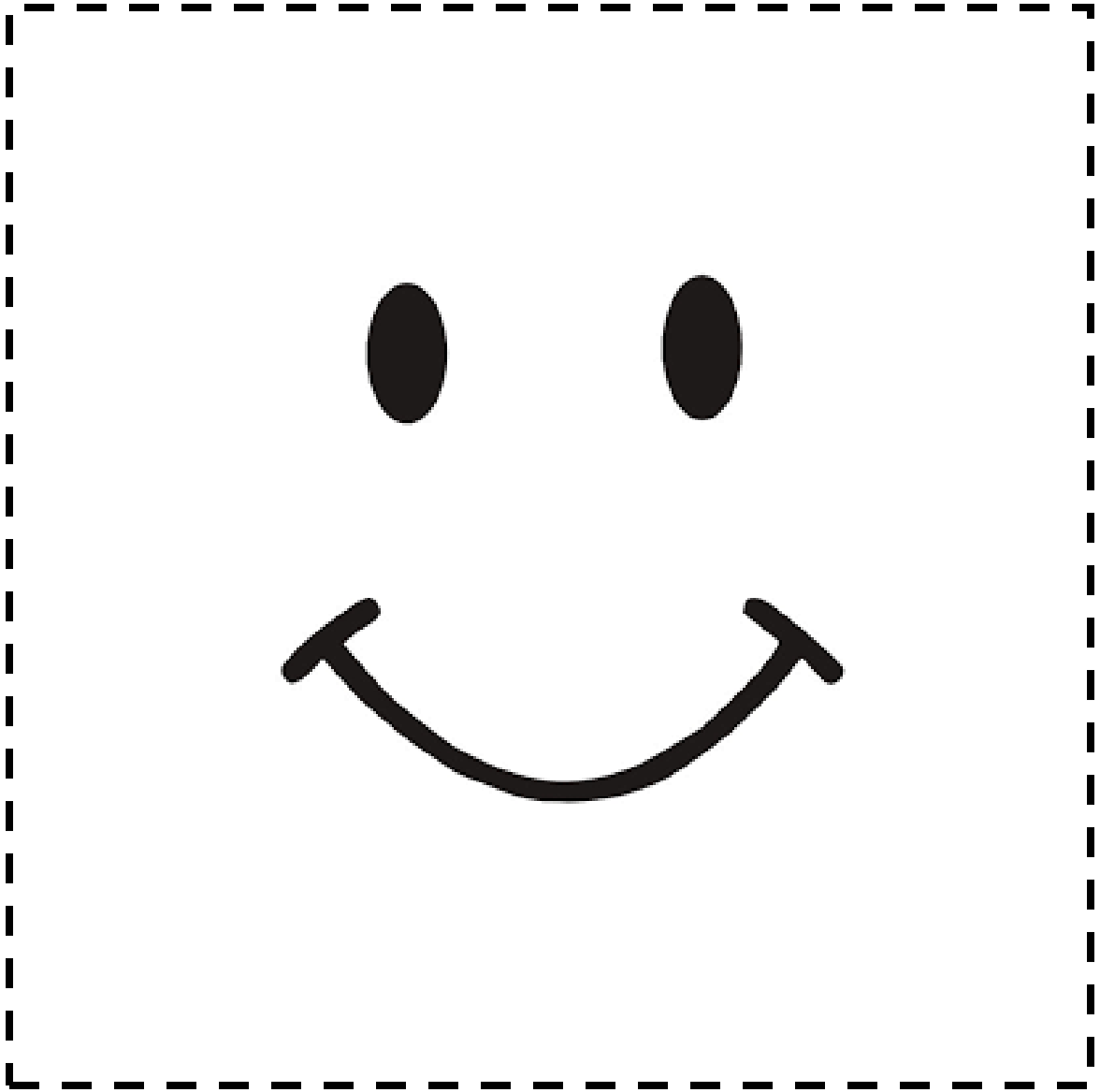

Let's cut!

Cut the circle out

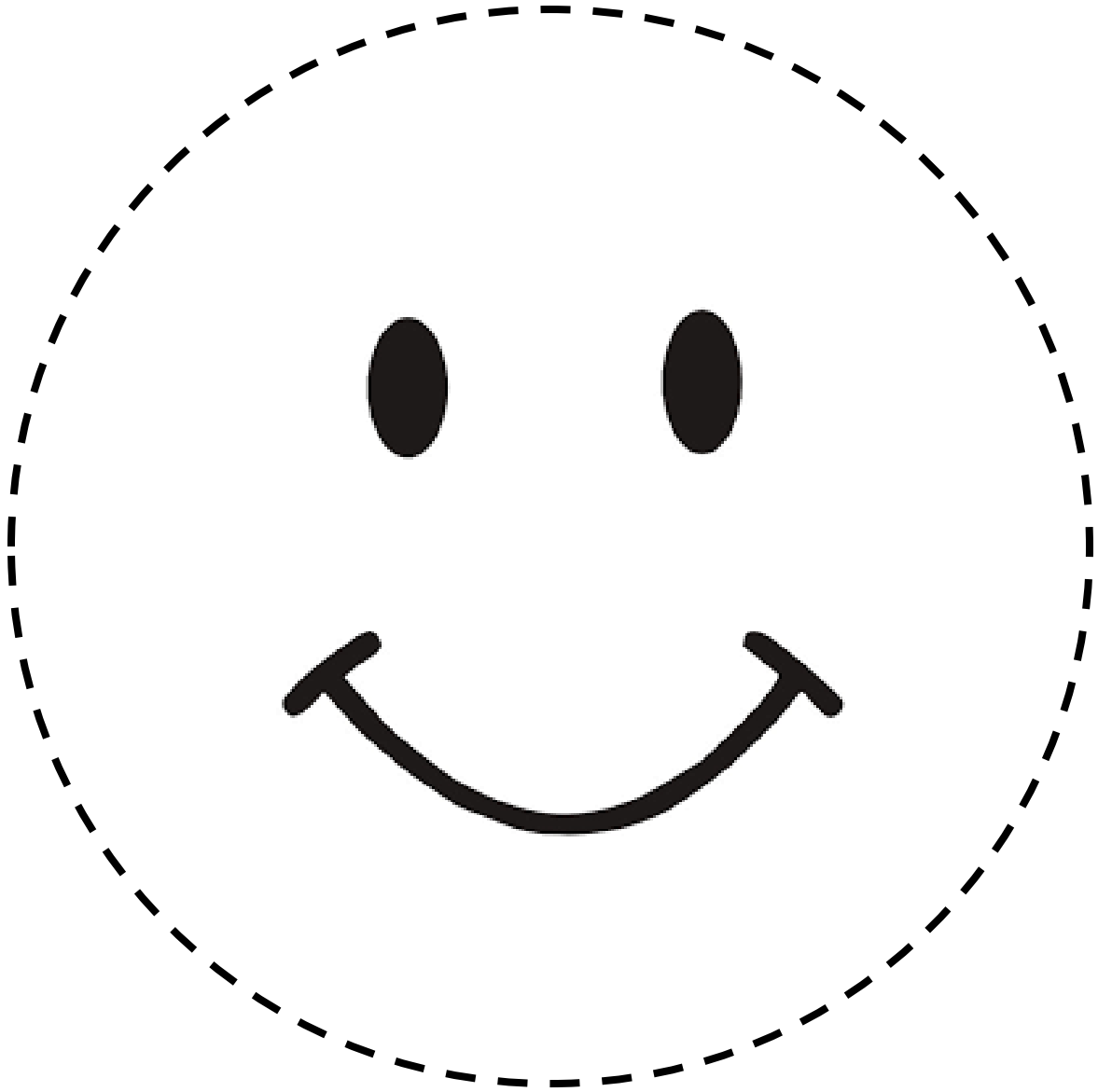

Circle fun

Practice the circle

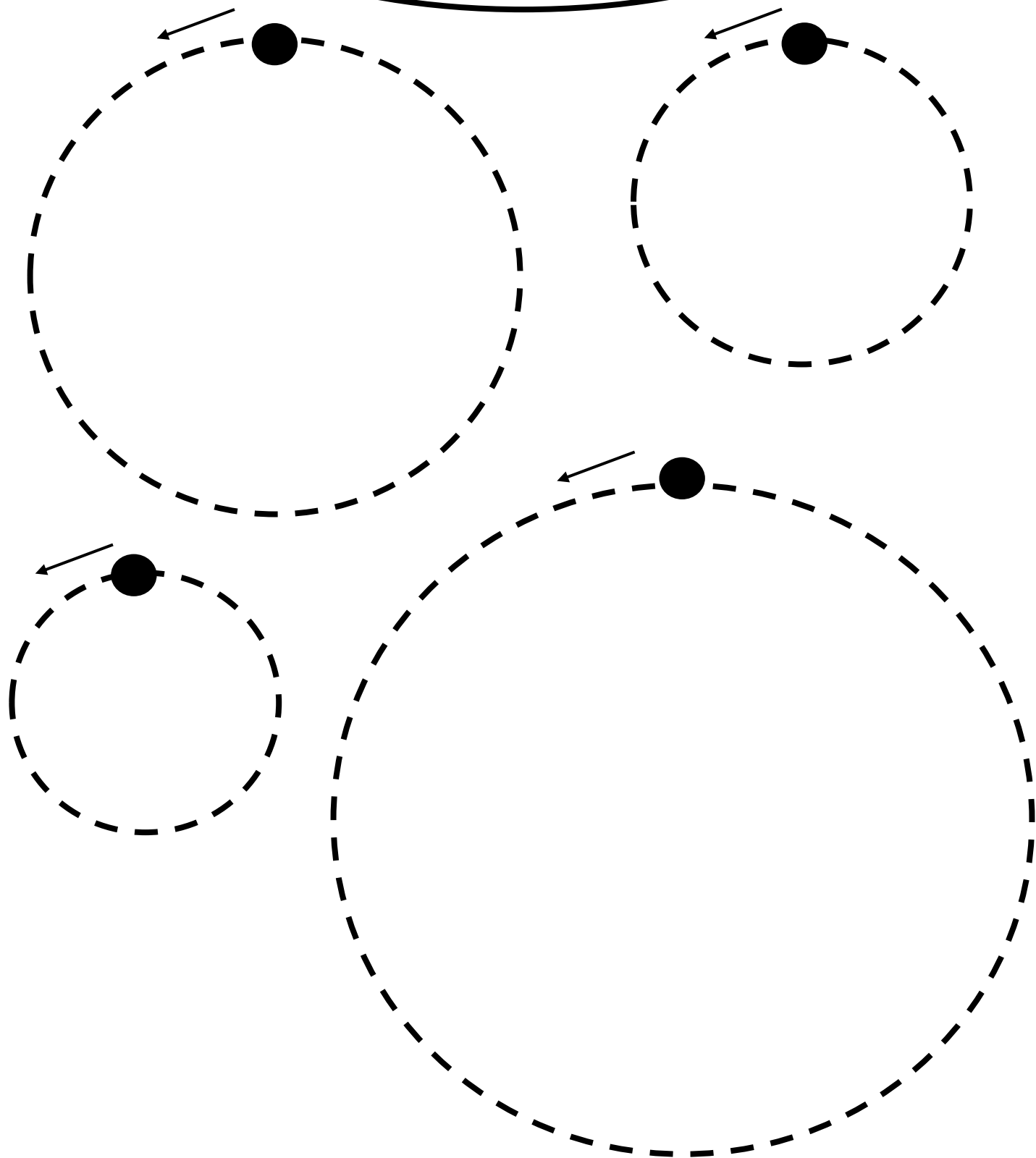
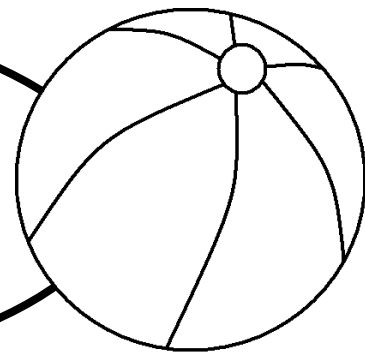

The bee is very loving.
Practice making
hearts for him

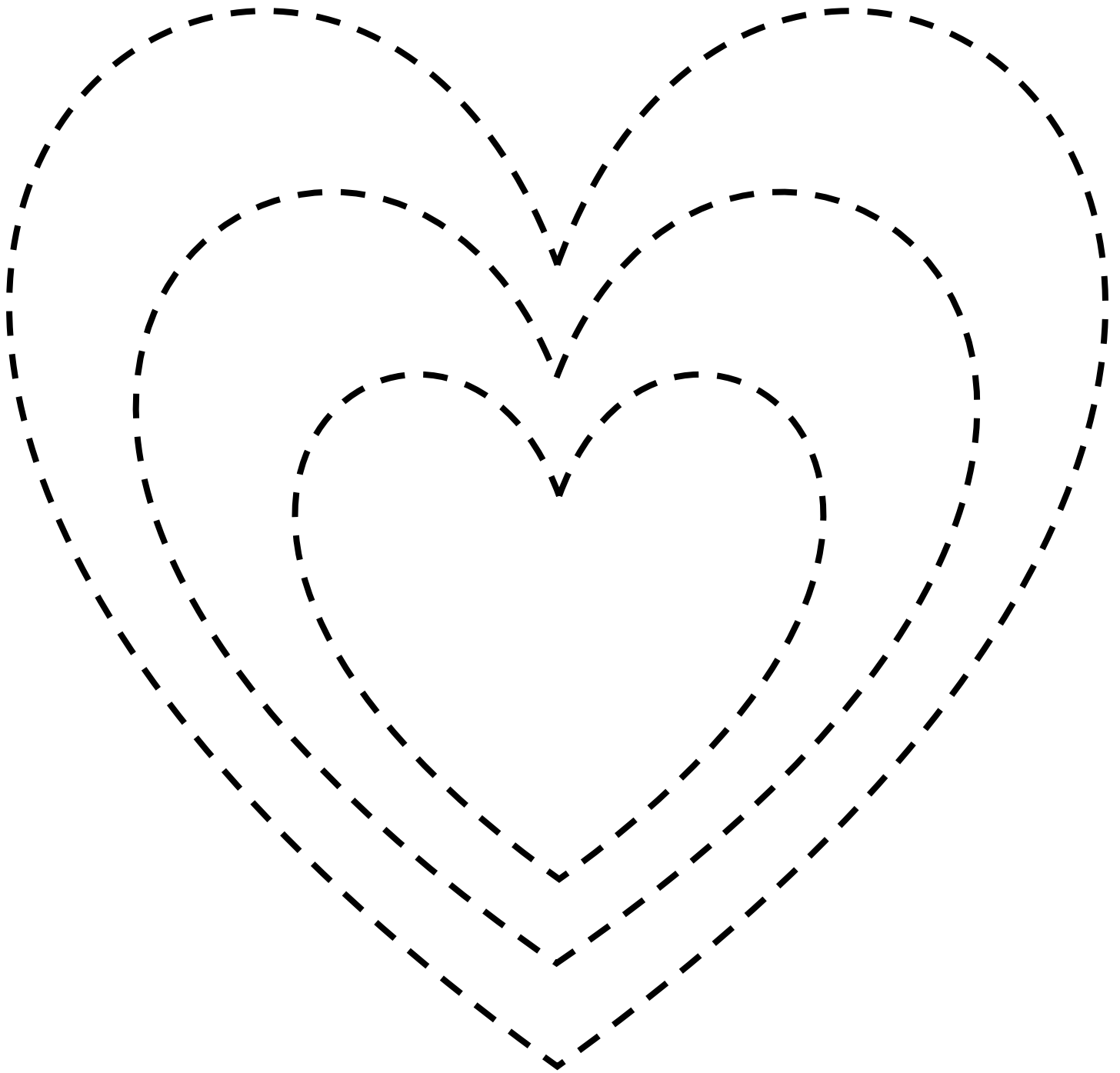
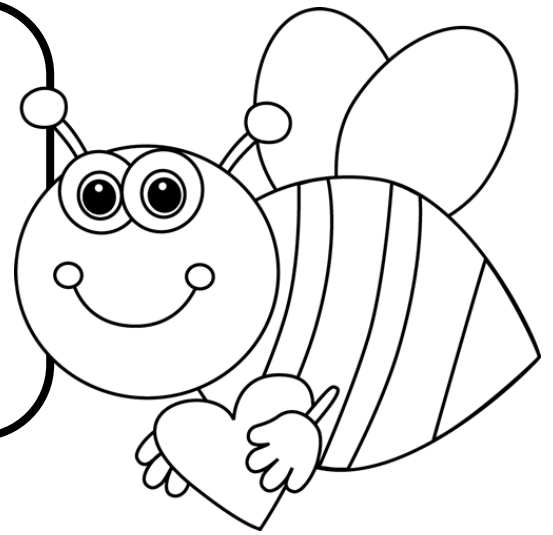

Complete the robot
patterns

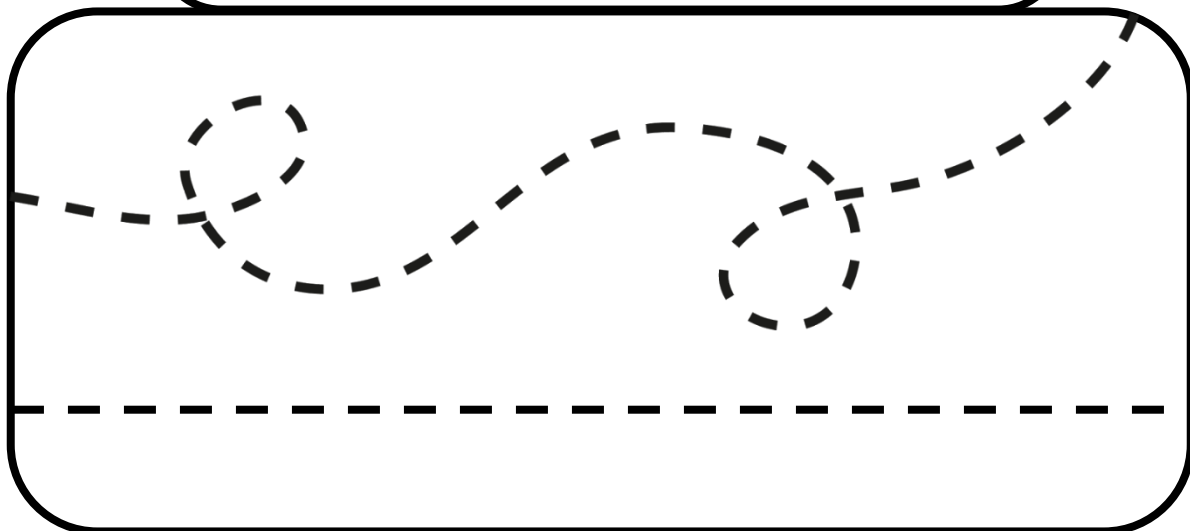
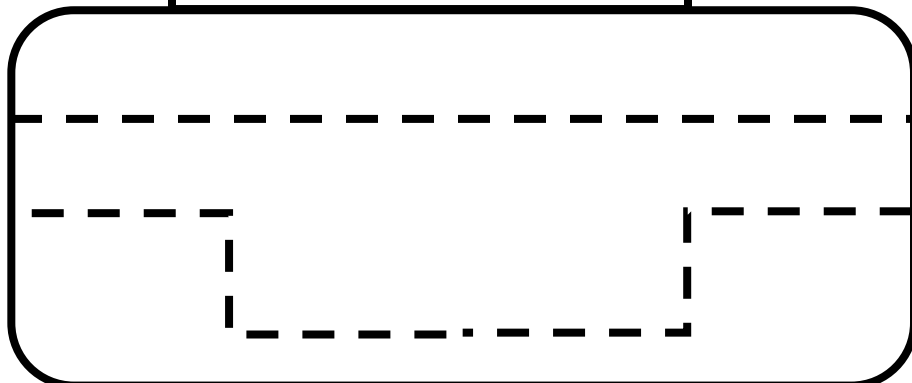
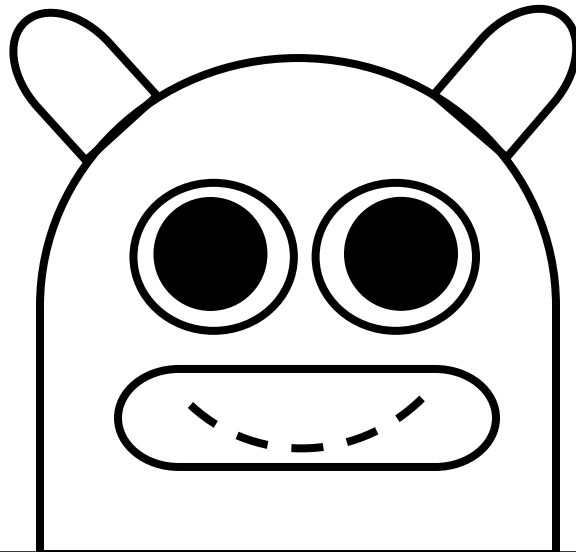

Let's practice the
square

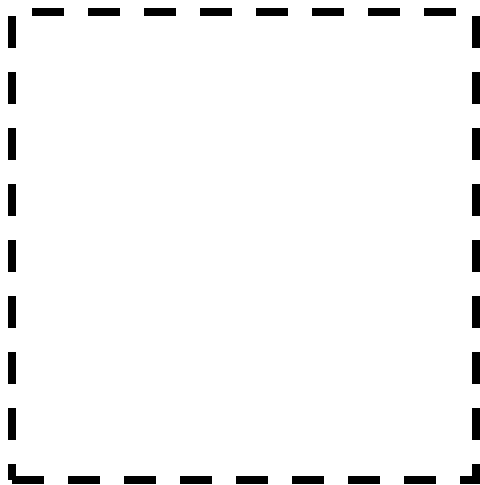
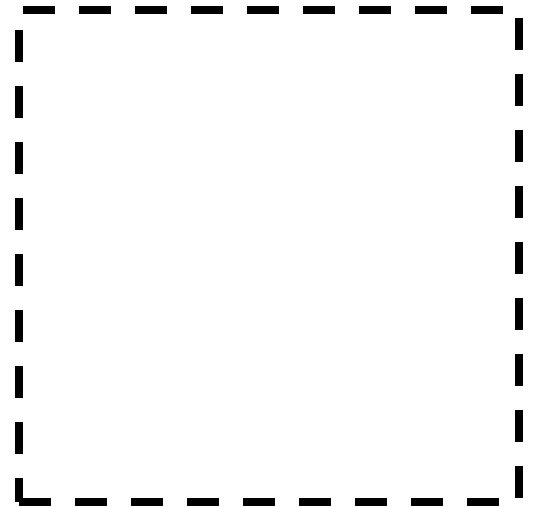
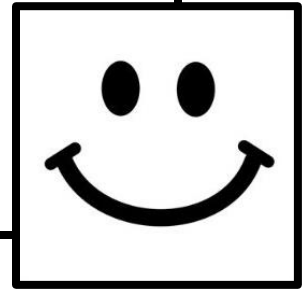

Complete the picture
on the dashed lines

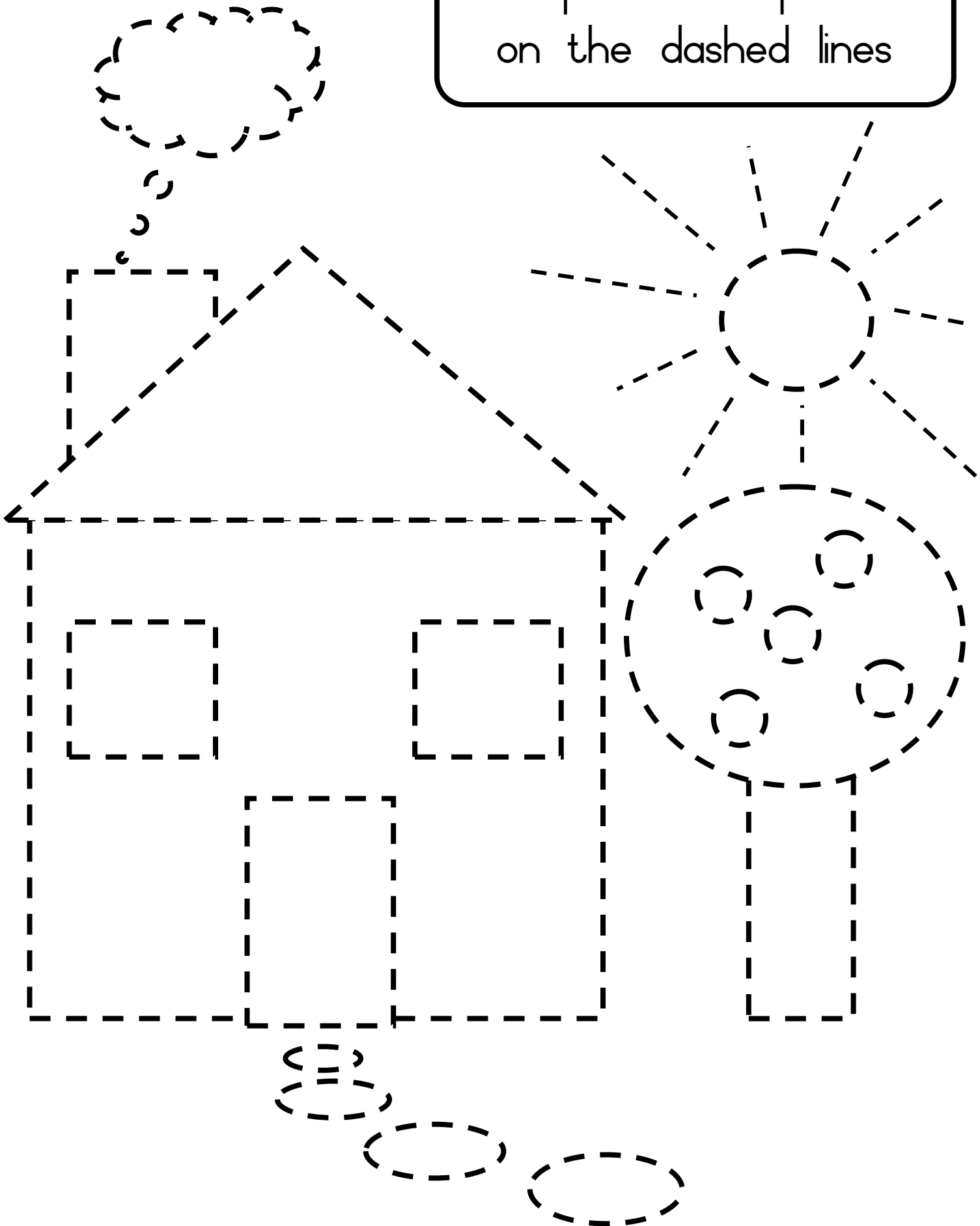

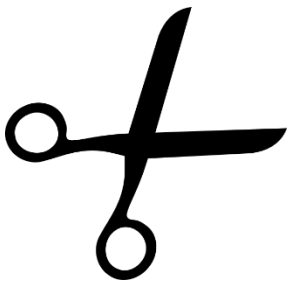

Color in the shapes, cut them out
and paste them with their partner
on the next page

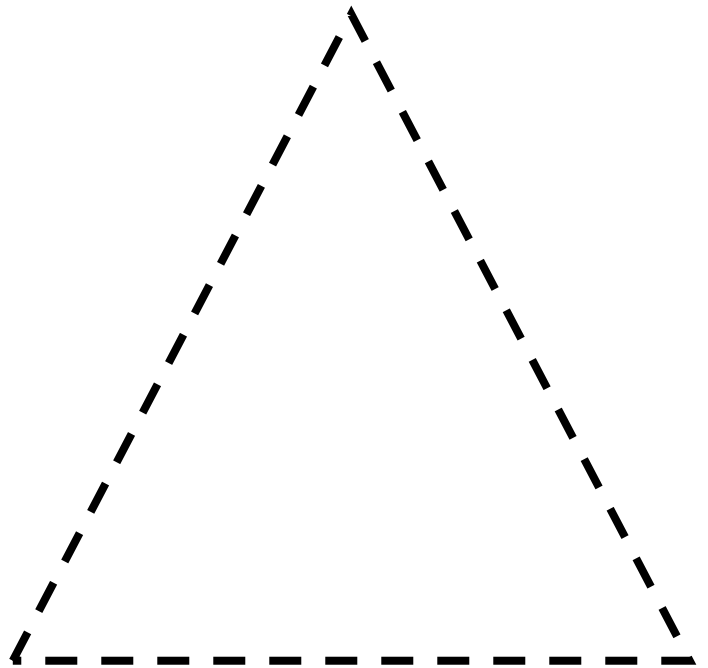
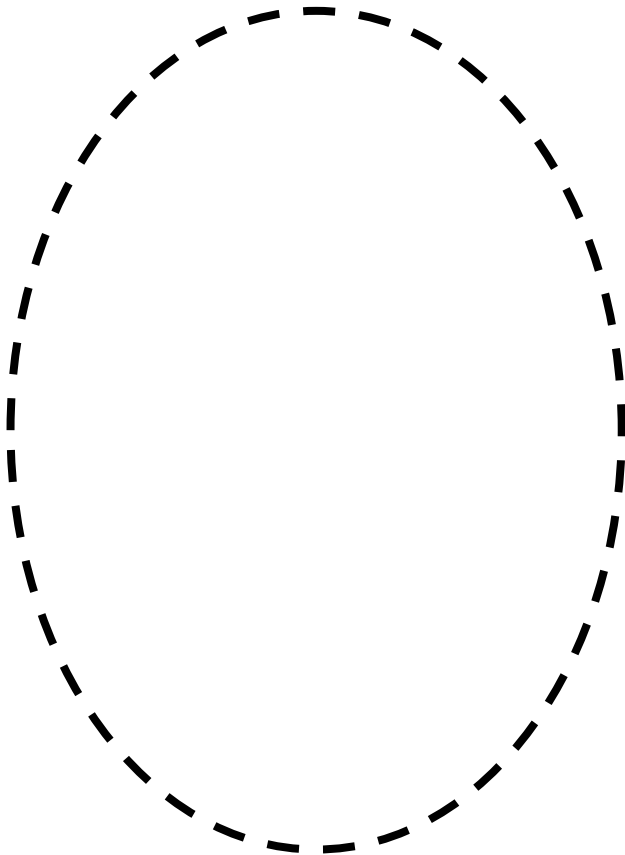
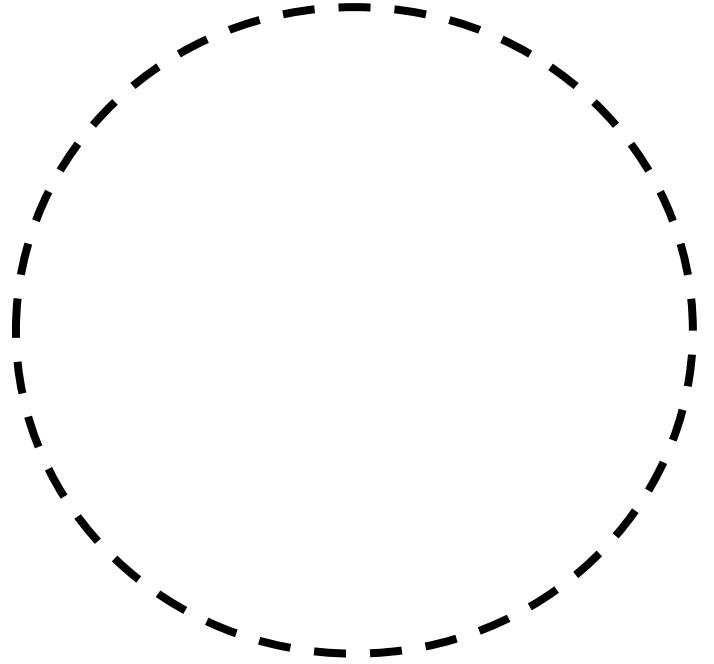

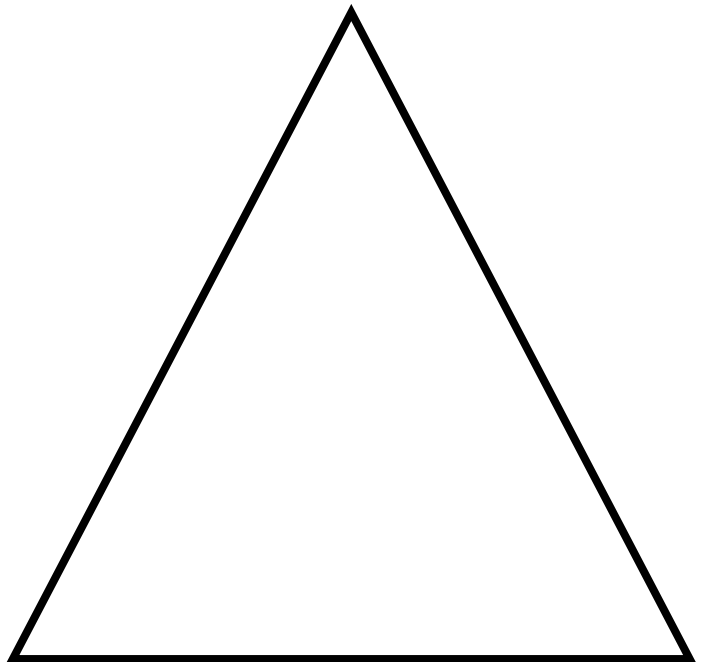
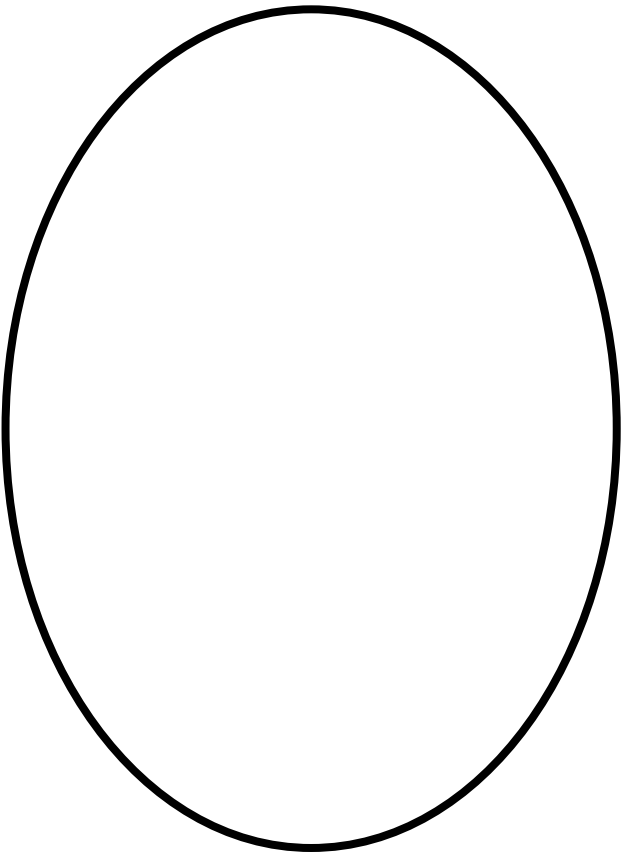
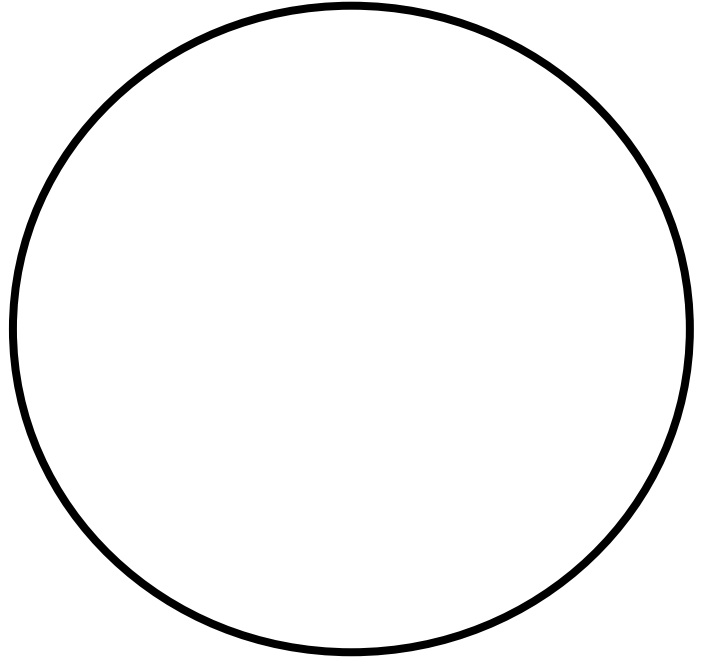

Use a magazine to cut out red pictures and paste them



Use a magazine to cut out blue
pictures and paste them

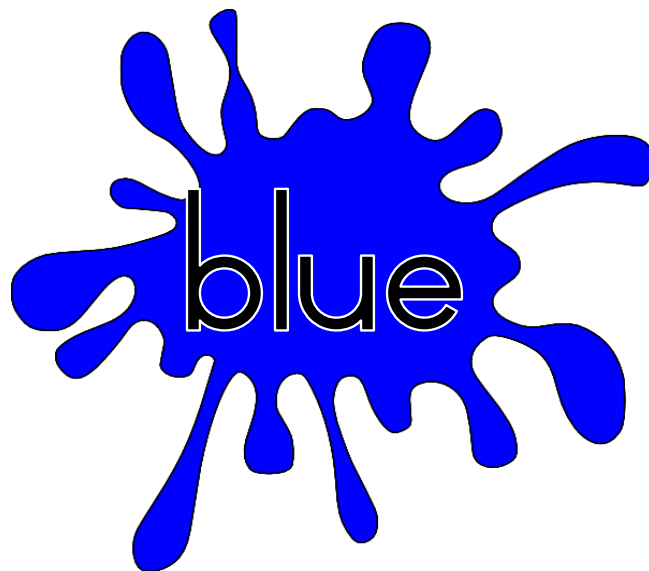

Use a magazine to cut out purple
pictures and paste them

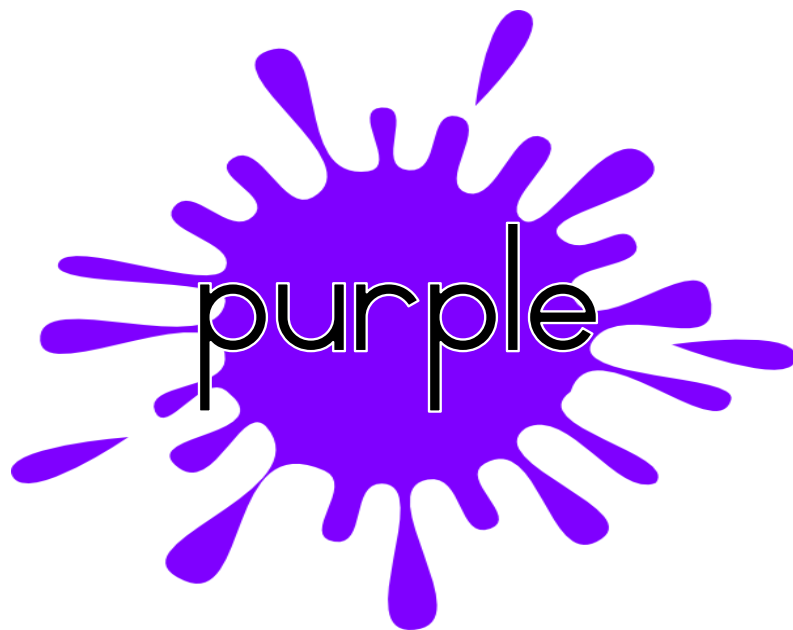

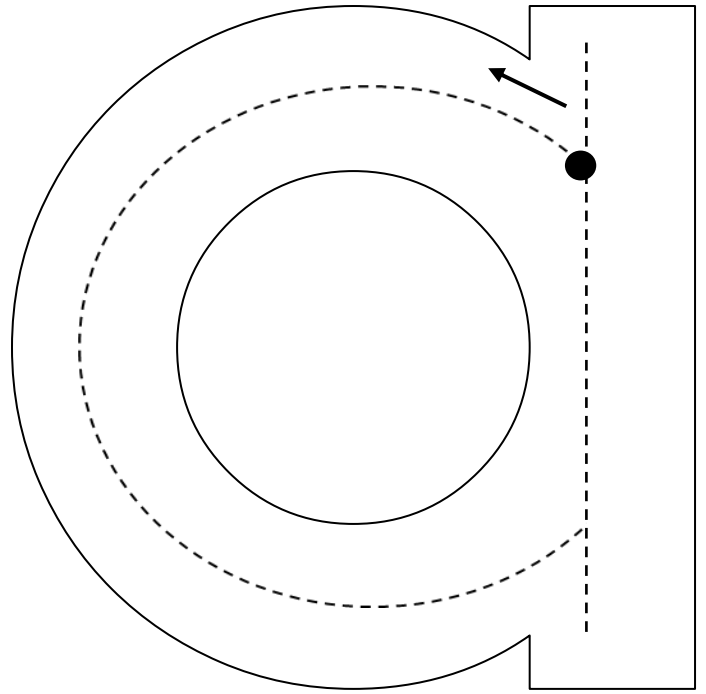
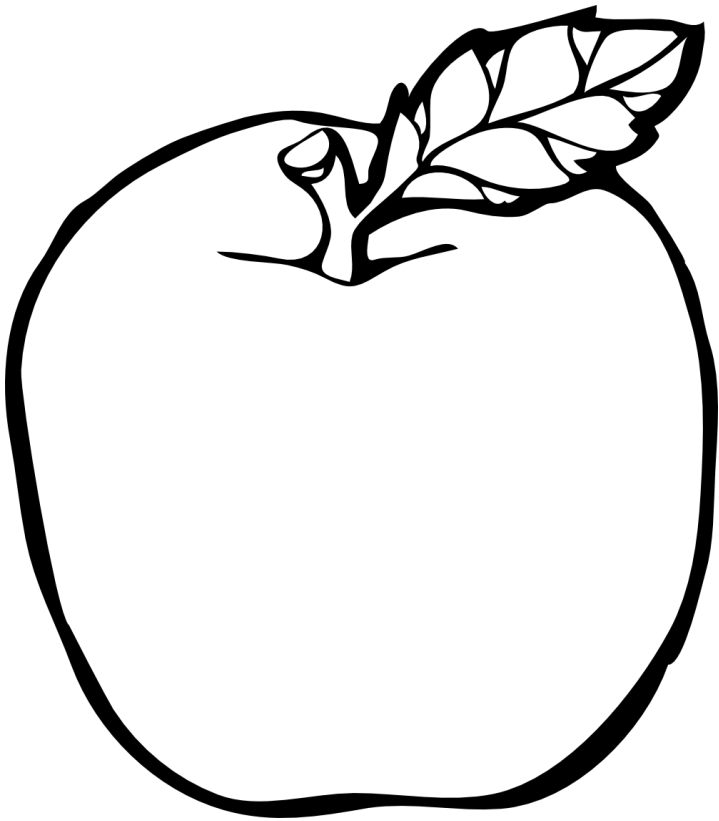

apple

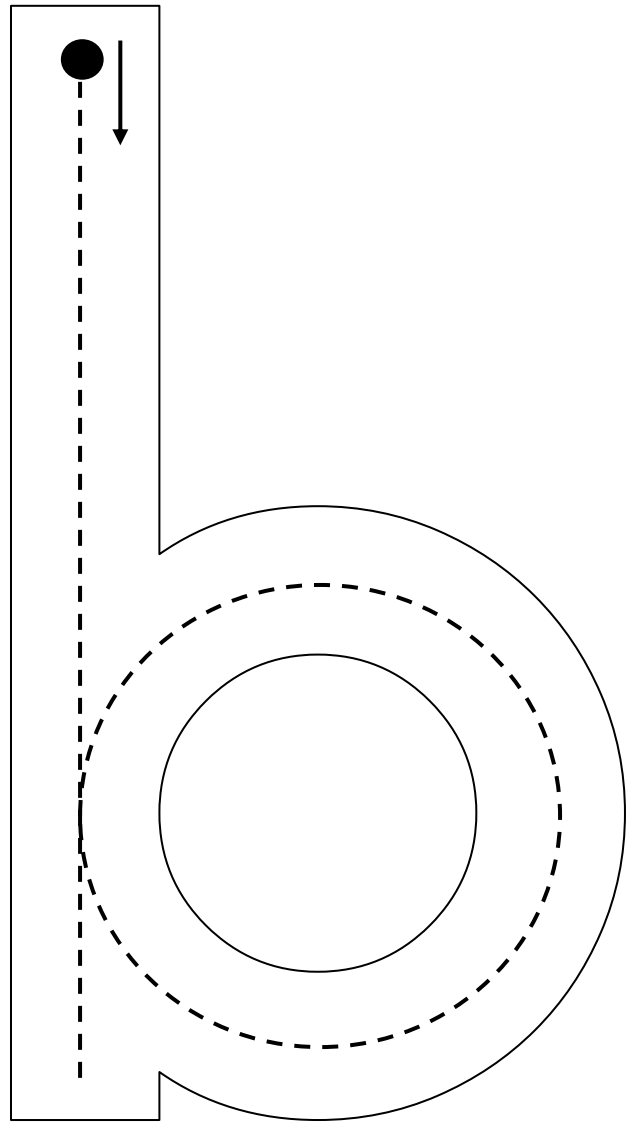

ball

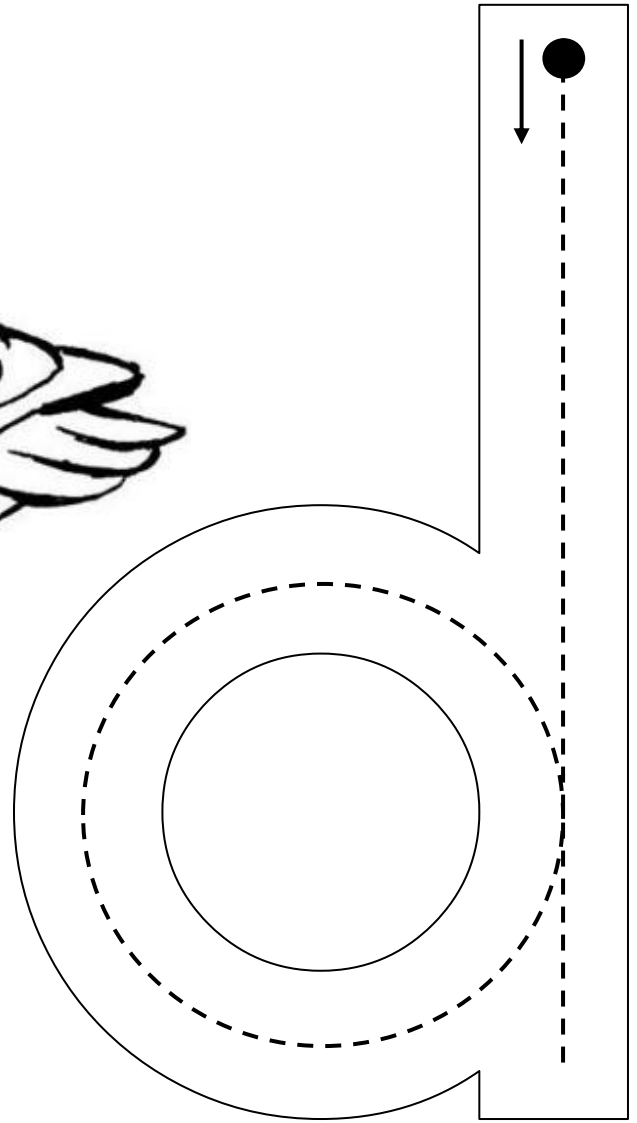
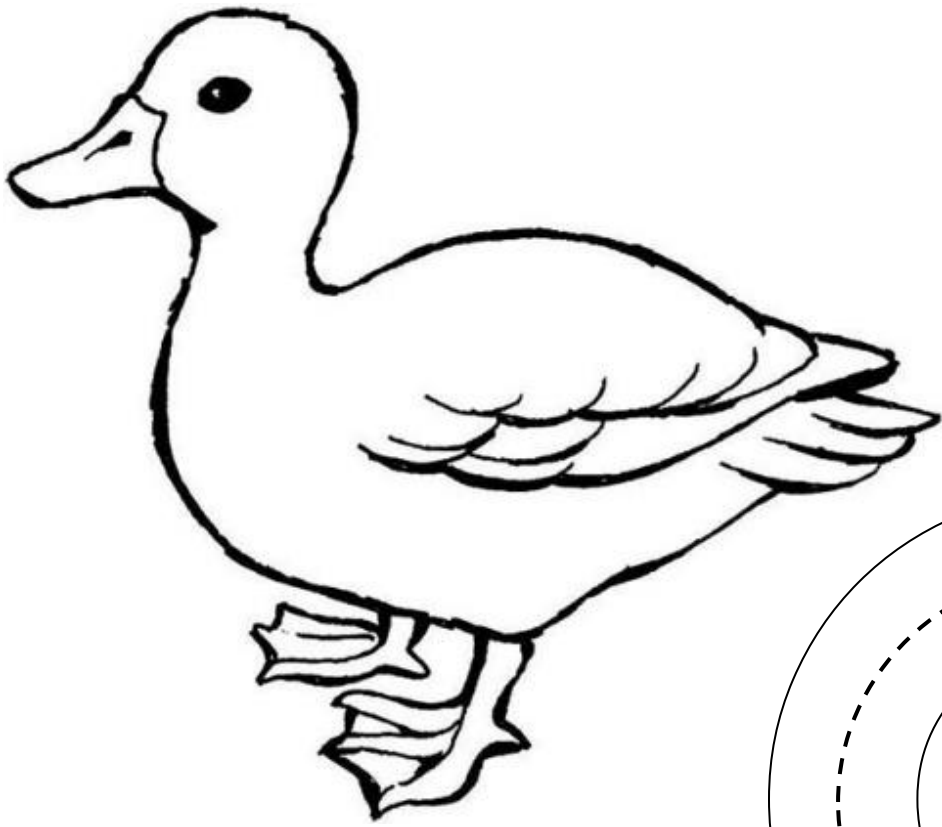

duck

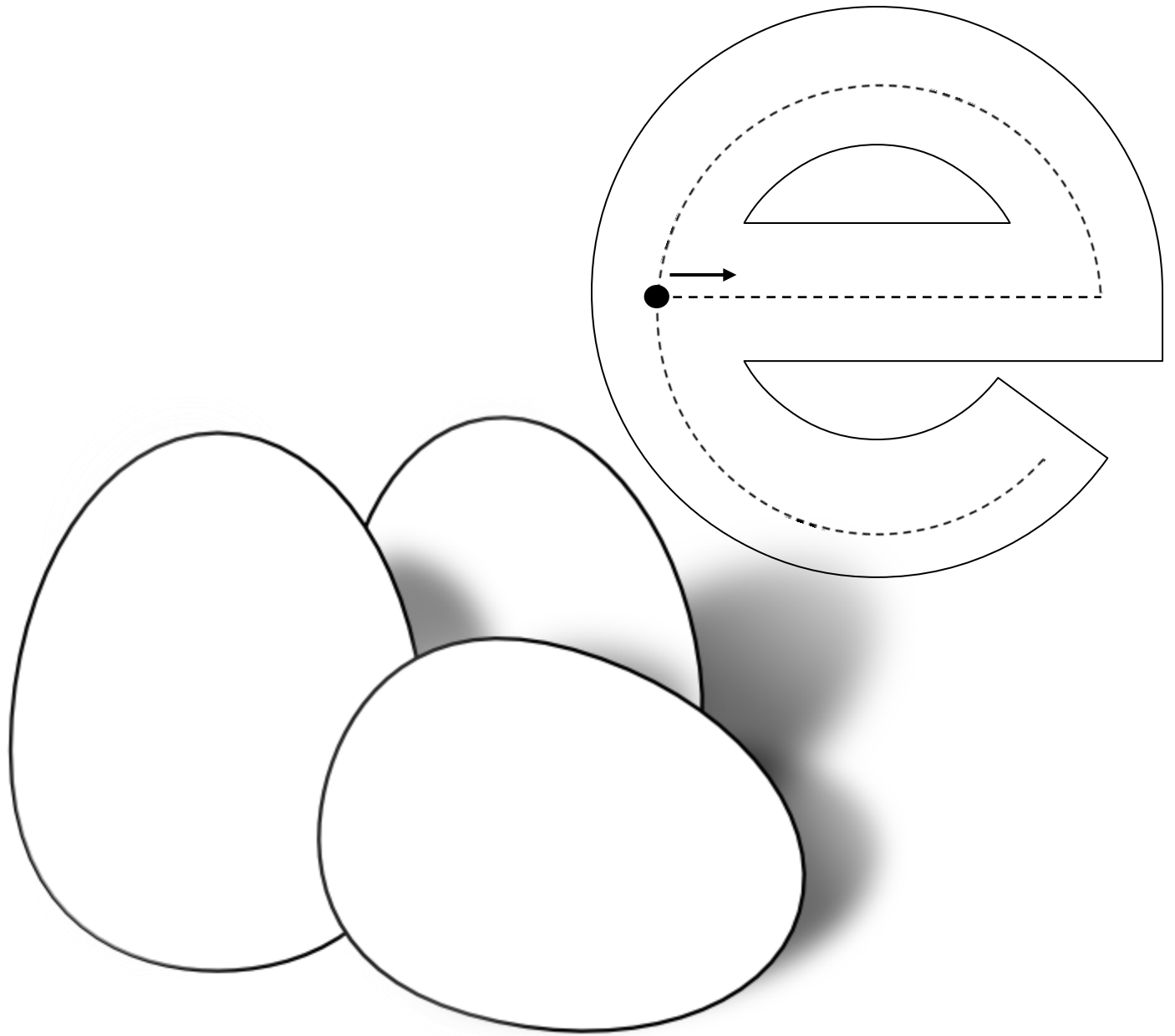

e gg gg

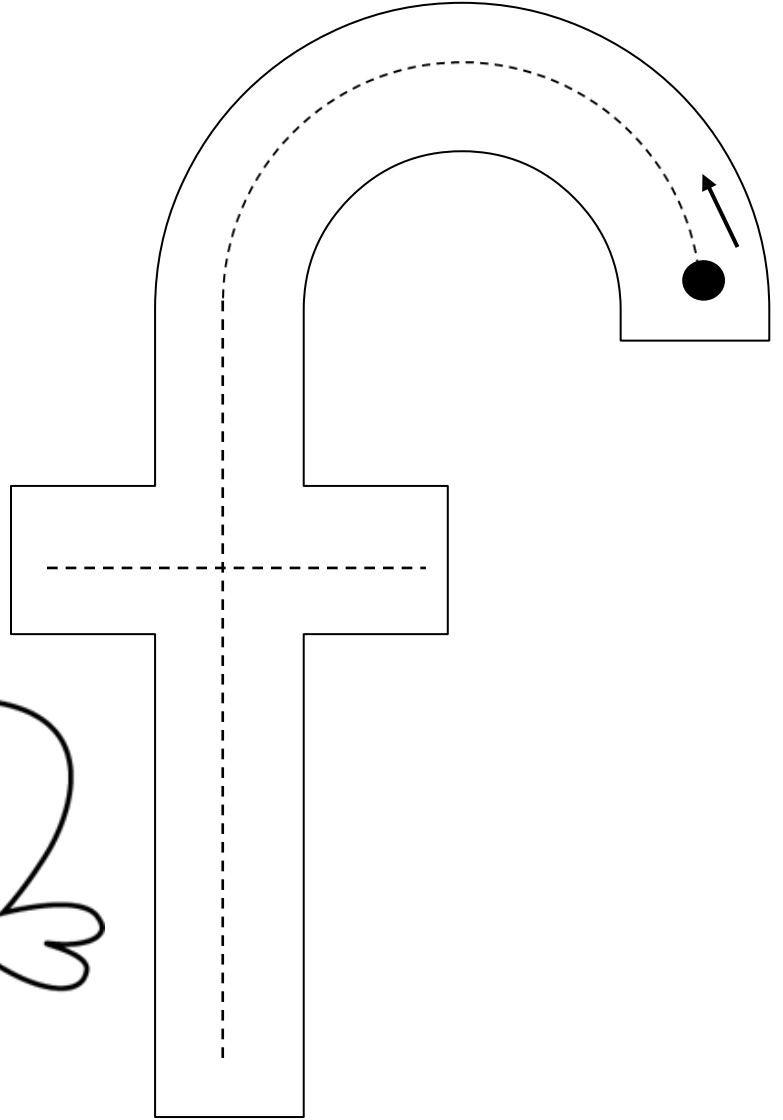
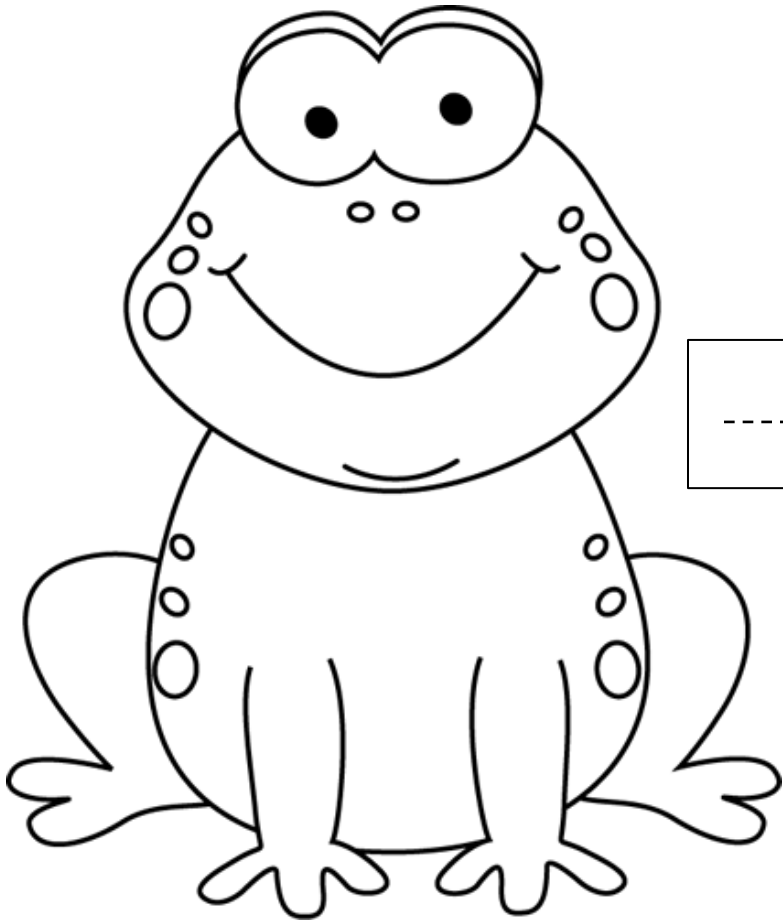

f r o g

How many
apples are
there?

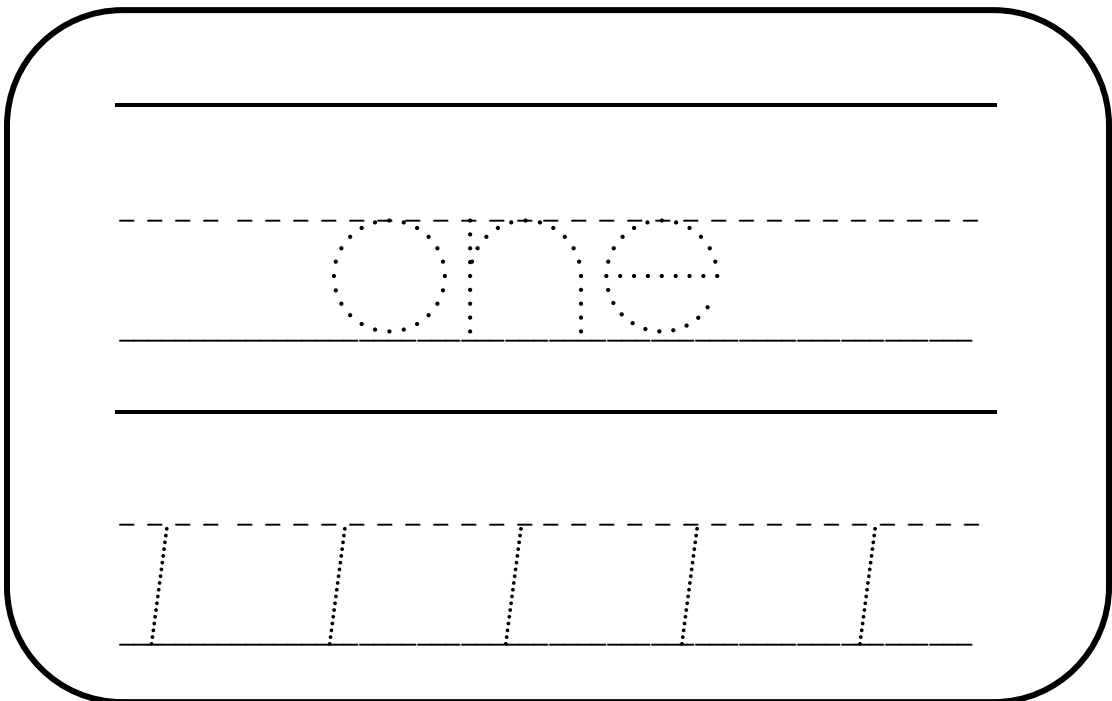
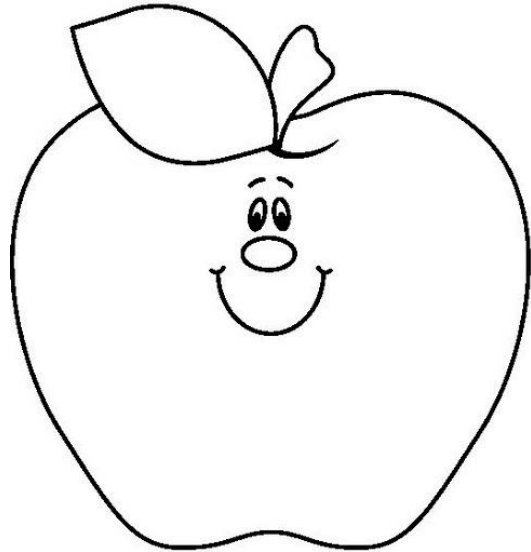
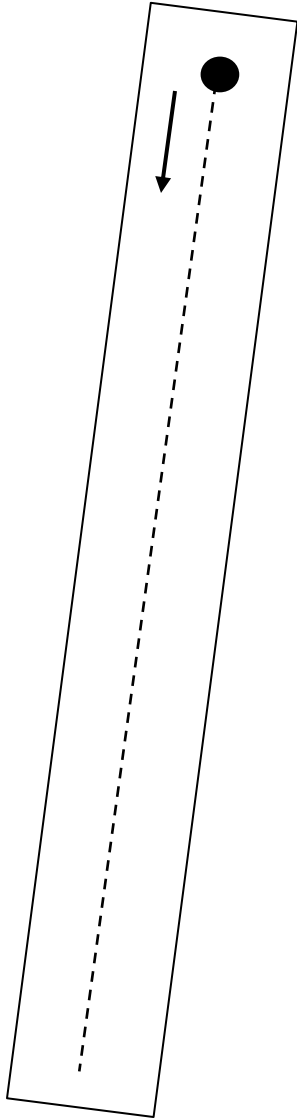

How many apples
are there?

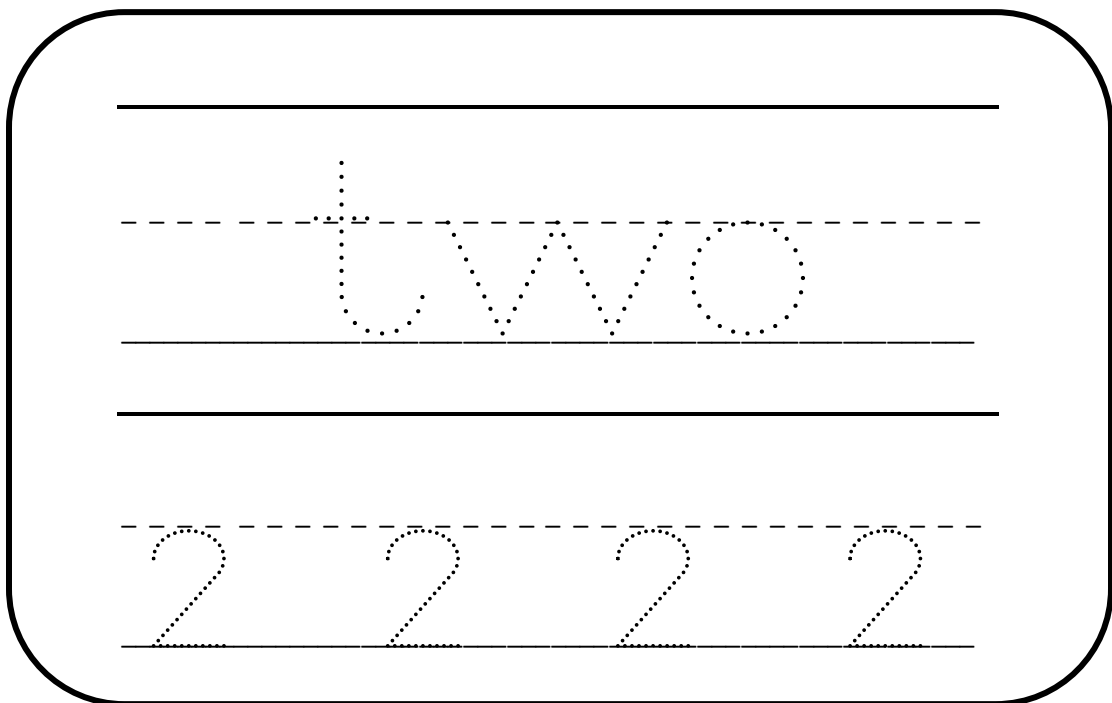
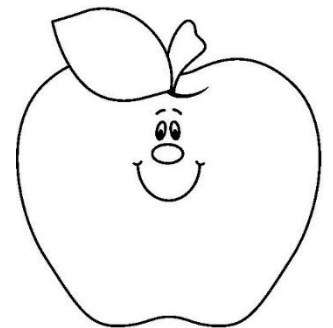
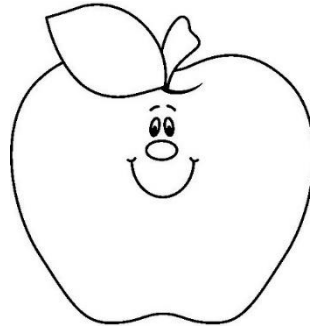
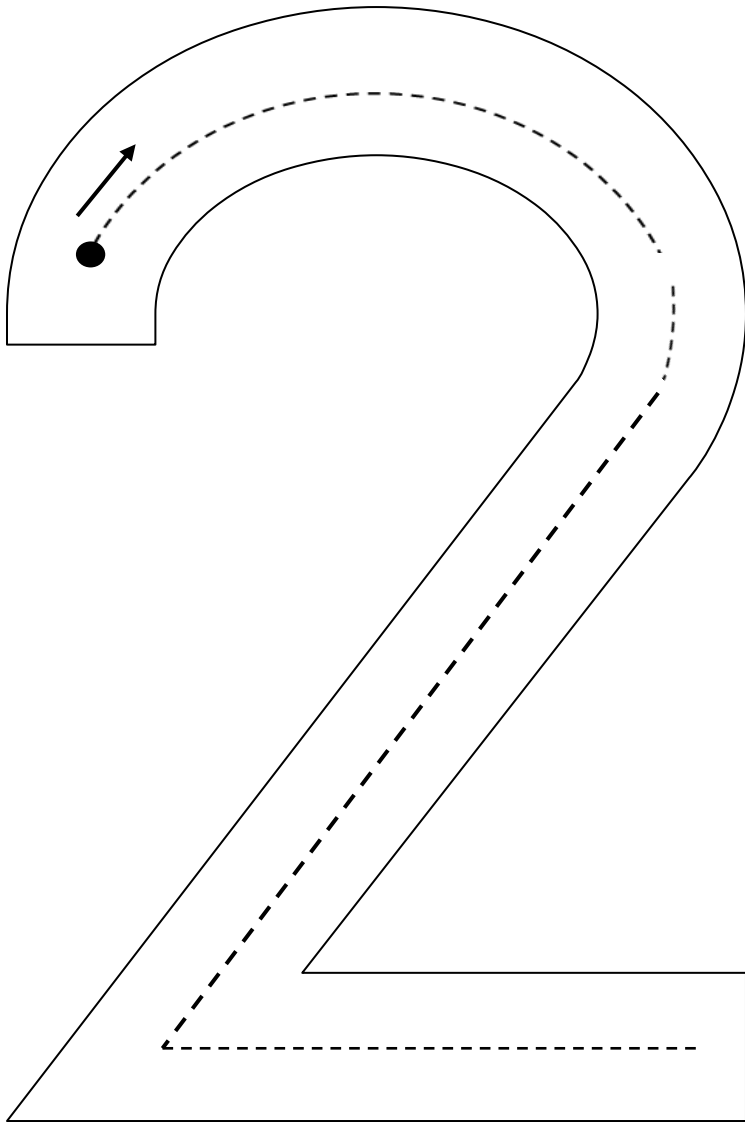

How many apples
are there?

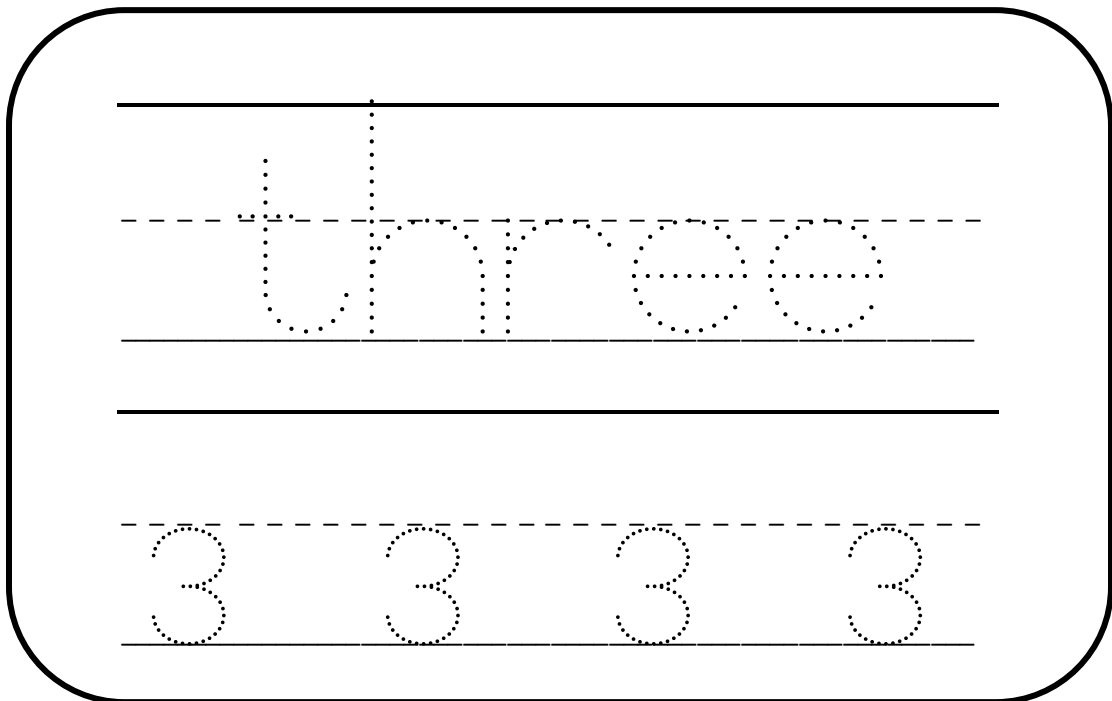
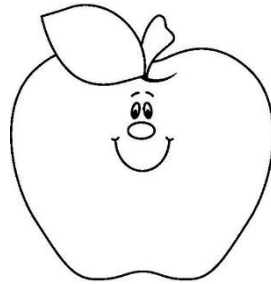
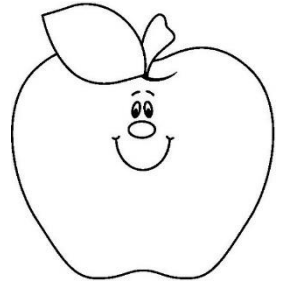
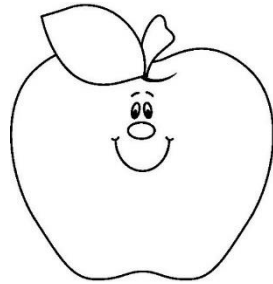
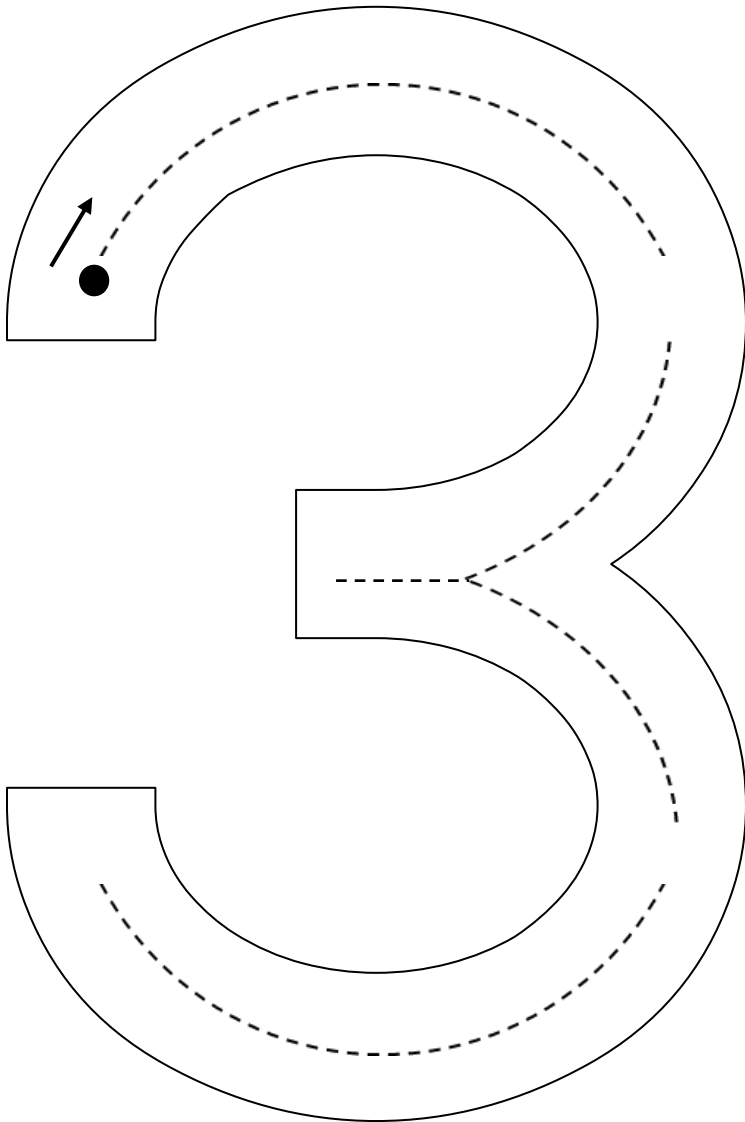

How many apples are there?

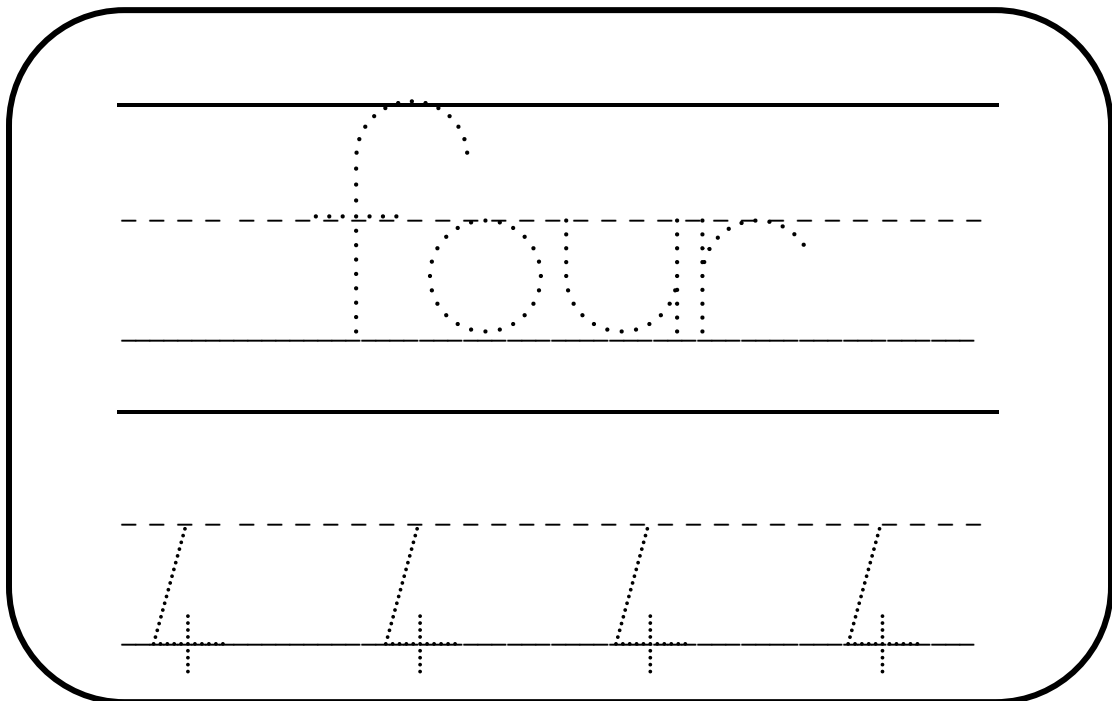
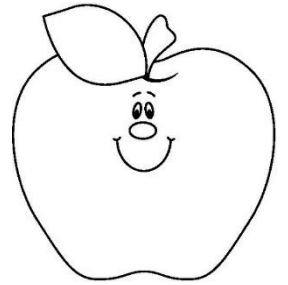
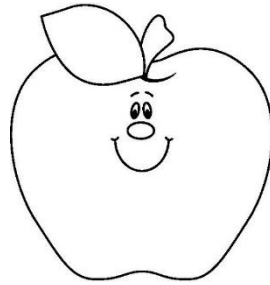
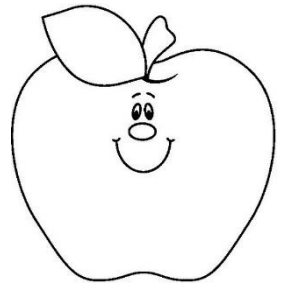
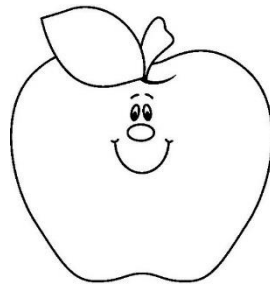
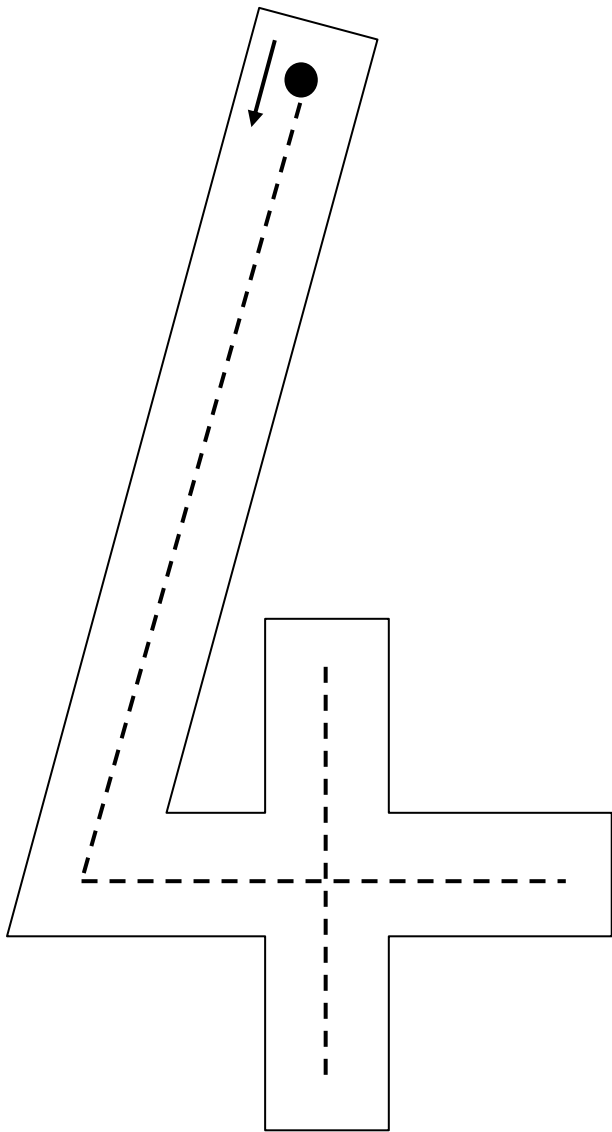

How many apples are there?

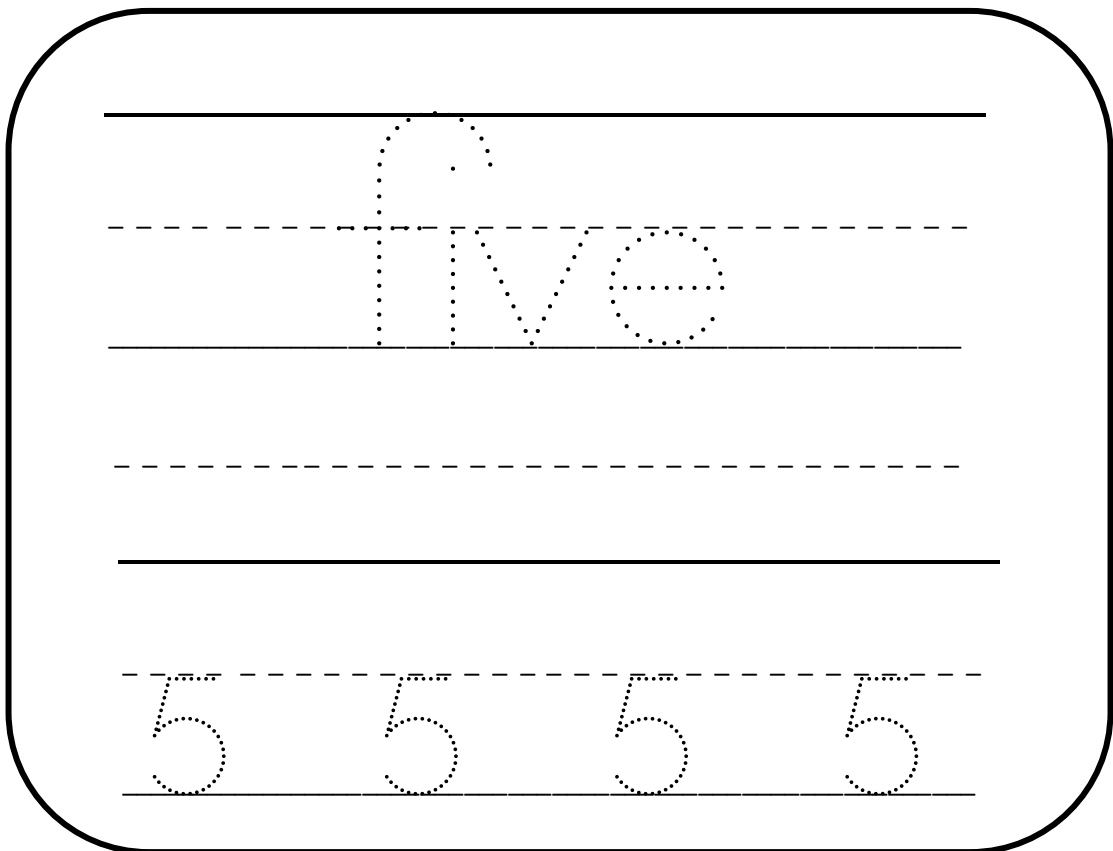
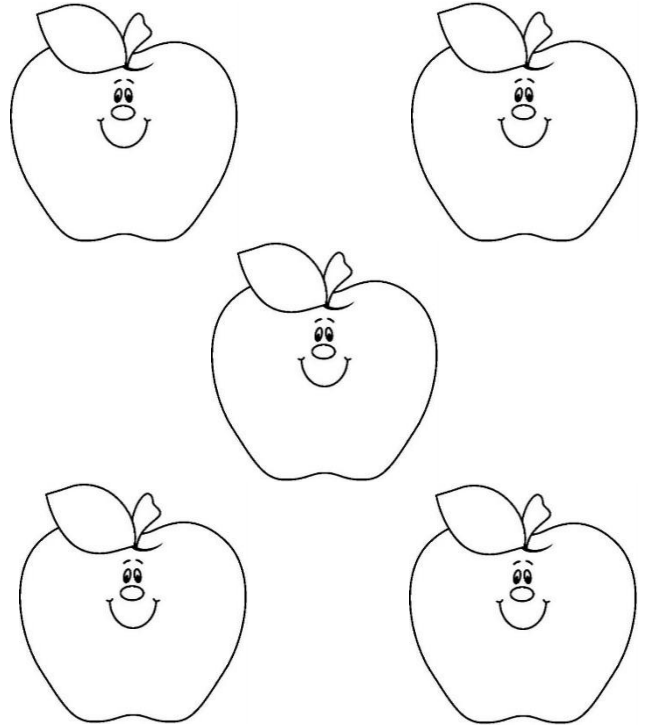
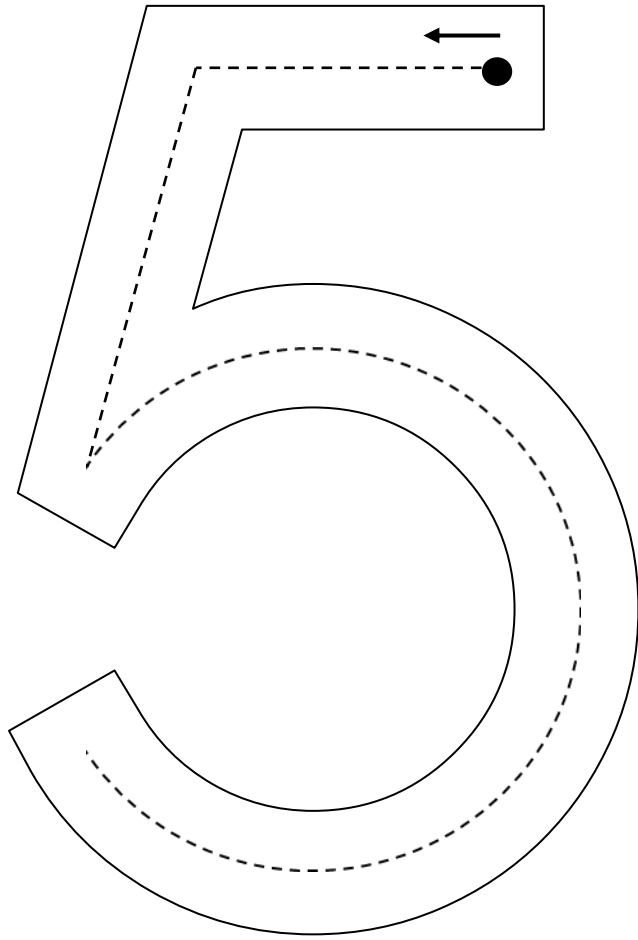

I know my colors!

Color the picture the right color
and write the word

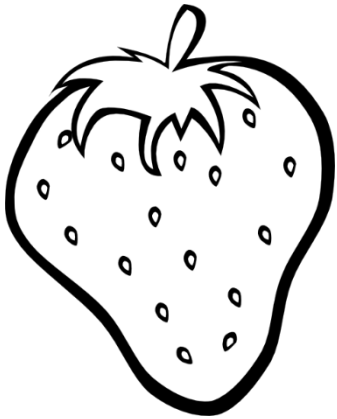

red

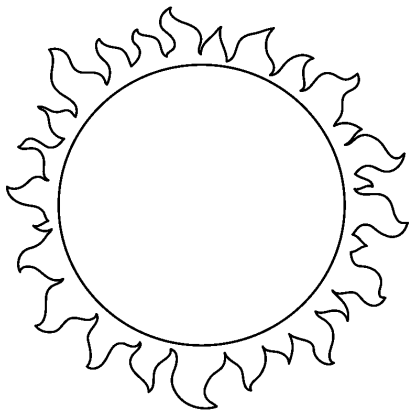

yellow

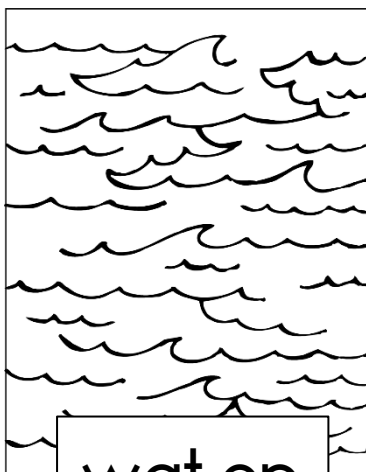

water

blue

The leaf is

green

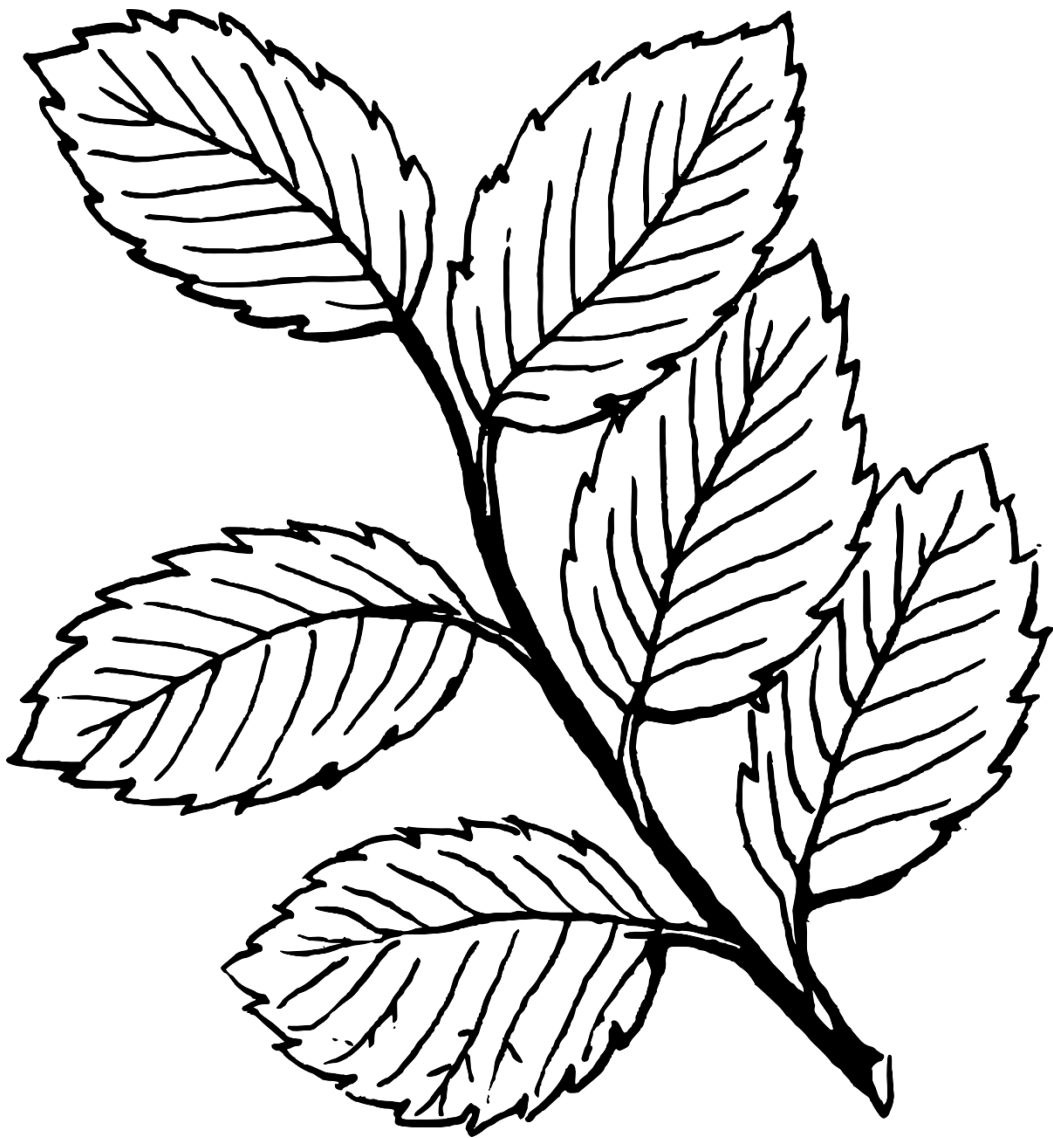

The orange

is orange

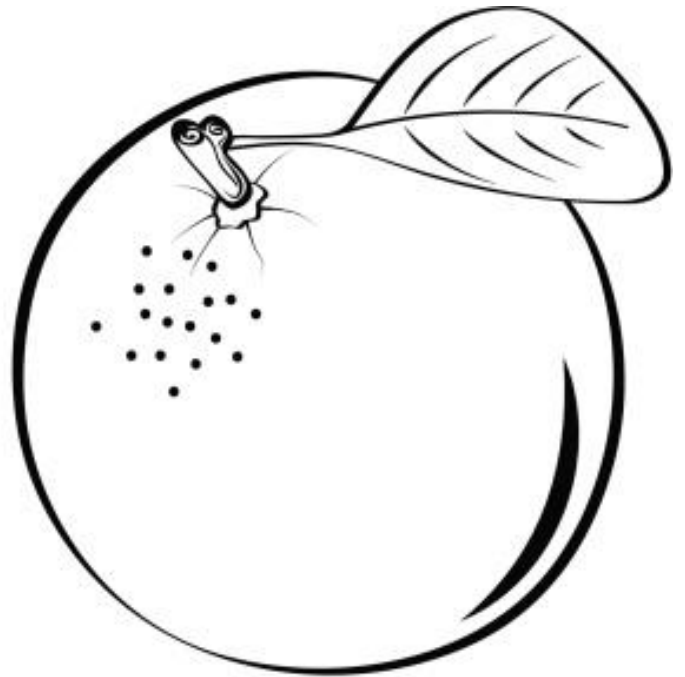
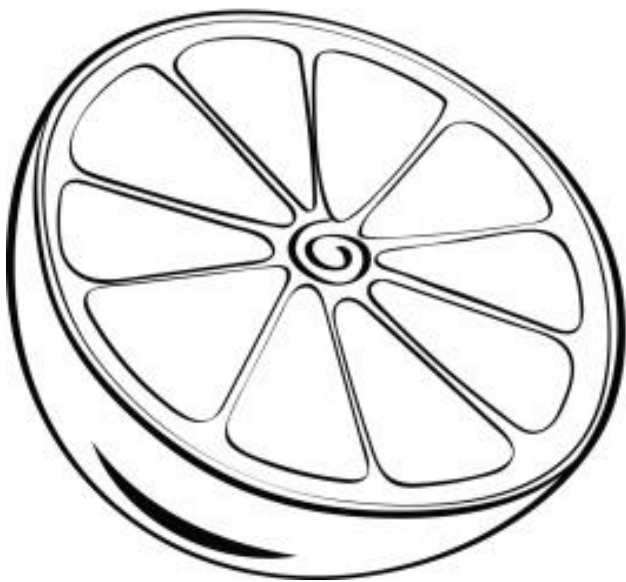

A decorative border of black circles surrounds the page. There are 7 circles in each of the top and bottom rows, and 10 circles in each of the left and right columns.





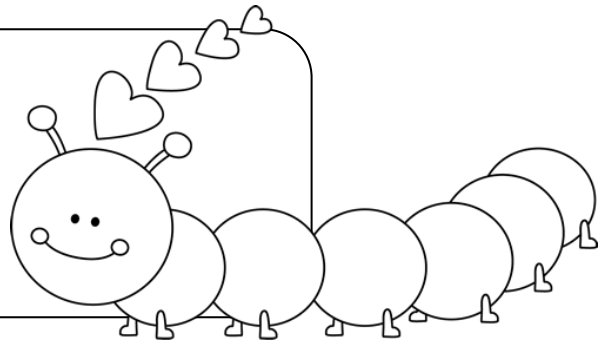

FINGERPAINT

The following activities is
fingerprint.

The child must dip the tip
off their finger into the
paint and complete the
activities

Make a body for the
worm



4		
1		
3		
5		
2		
6		

Give the flowers
petals.

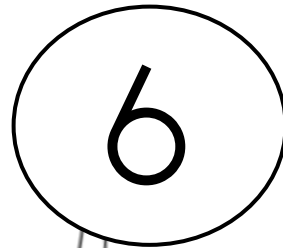
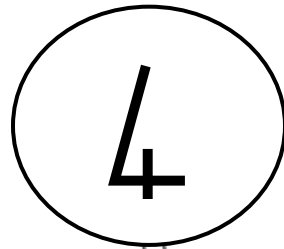

Dip your finger into the paint
to form the letters

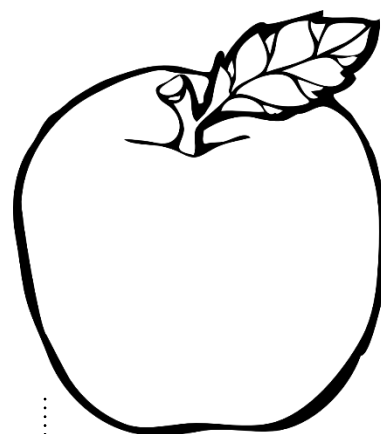
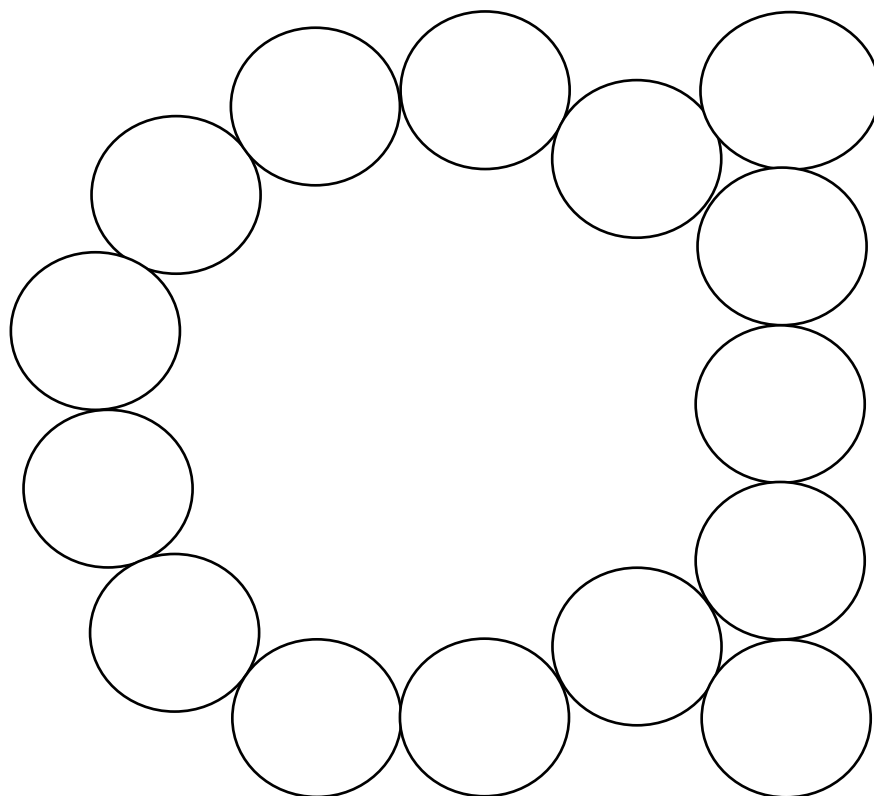

a is for

apple

Dip your finger into the paint
to form the letters

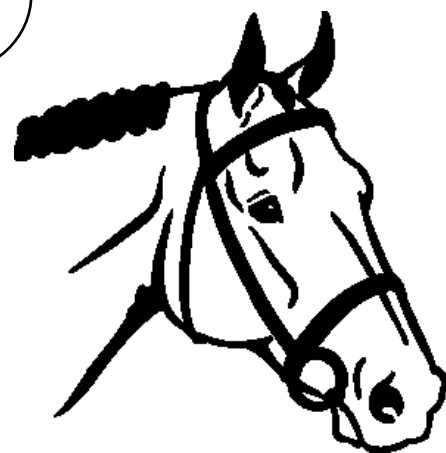
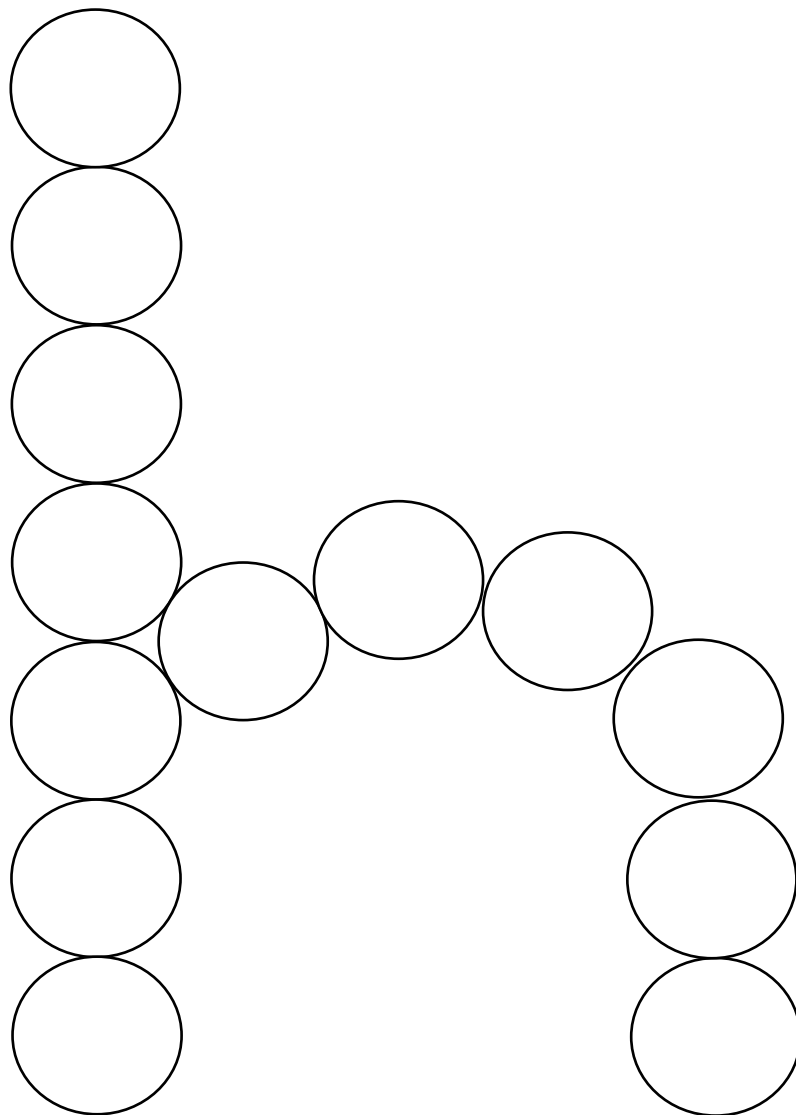

h is for

horse

Dip your finger into the paint
to form the letters

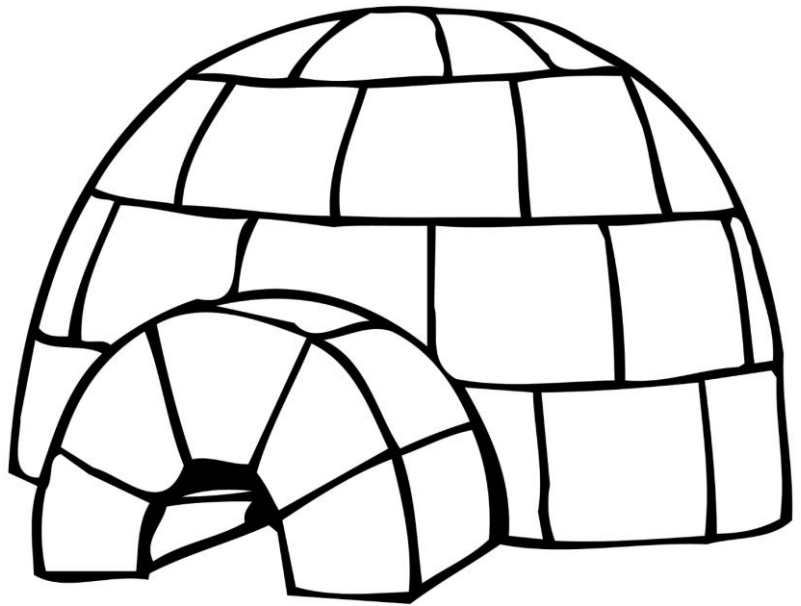
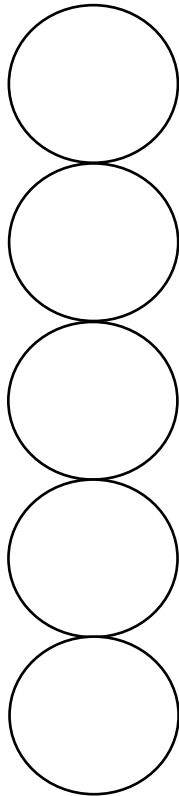
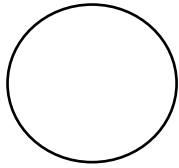

i is for igloo

Dip your finger into the paint
to form the letters

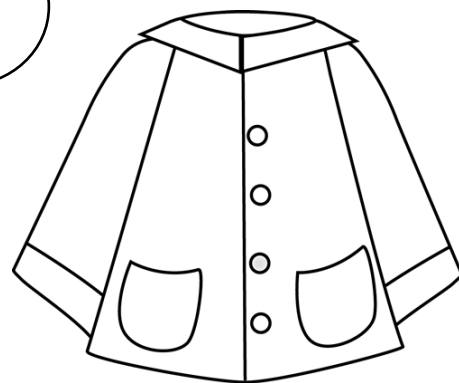
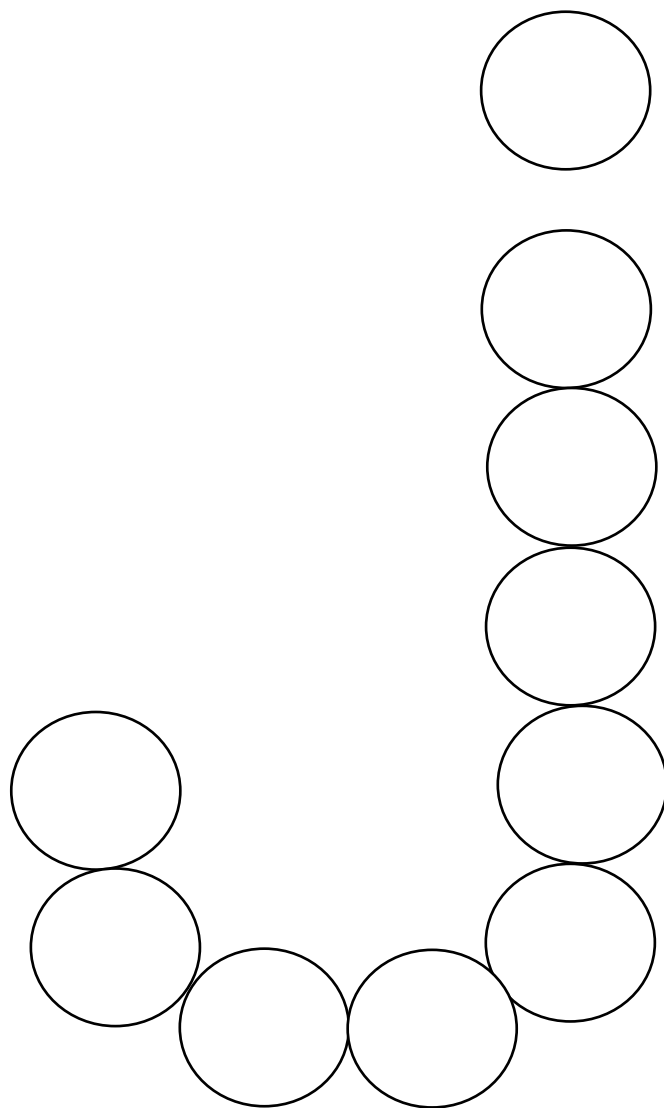

j is for

jacket

Dip your finger into the paint
to form the letters

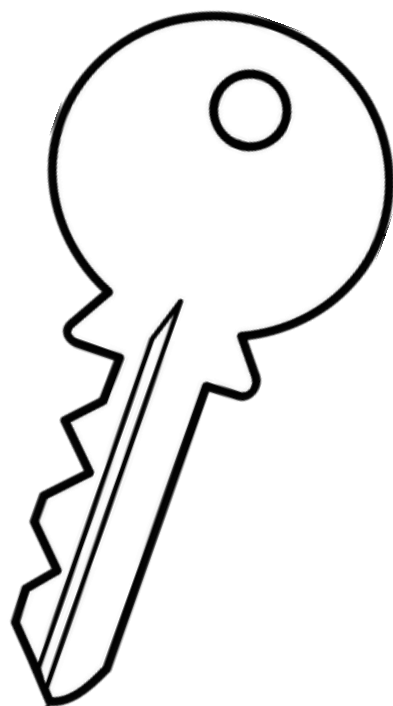
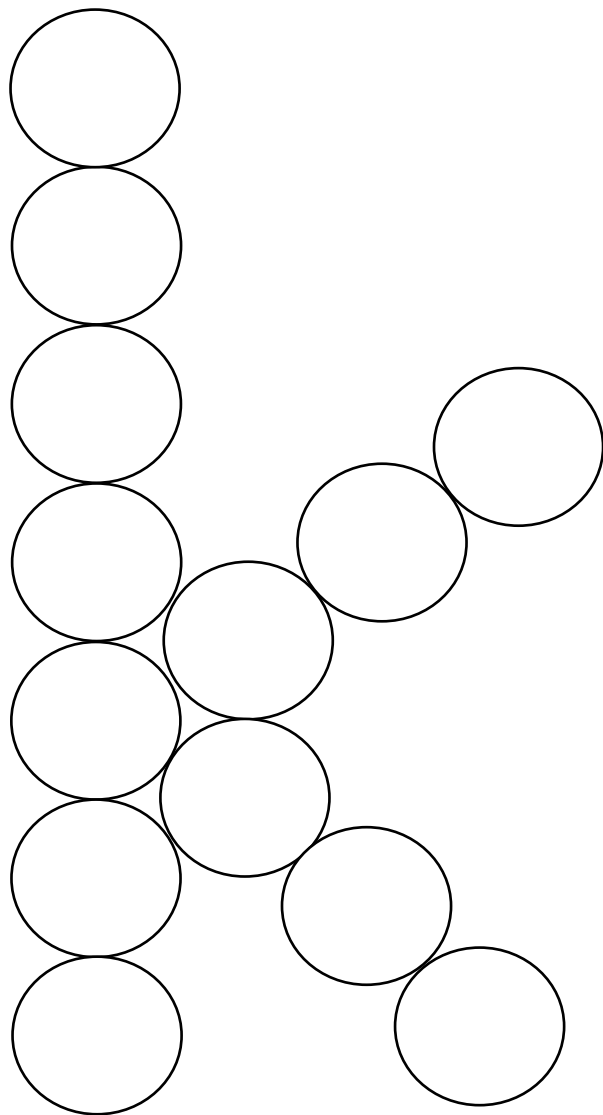

k is for

key

Dip your finger into the paint
to form the letters

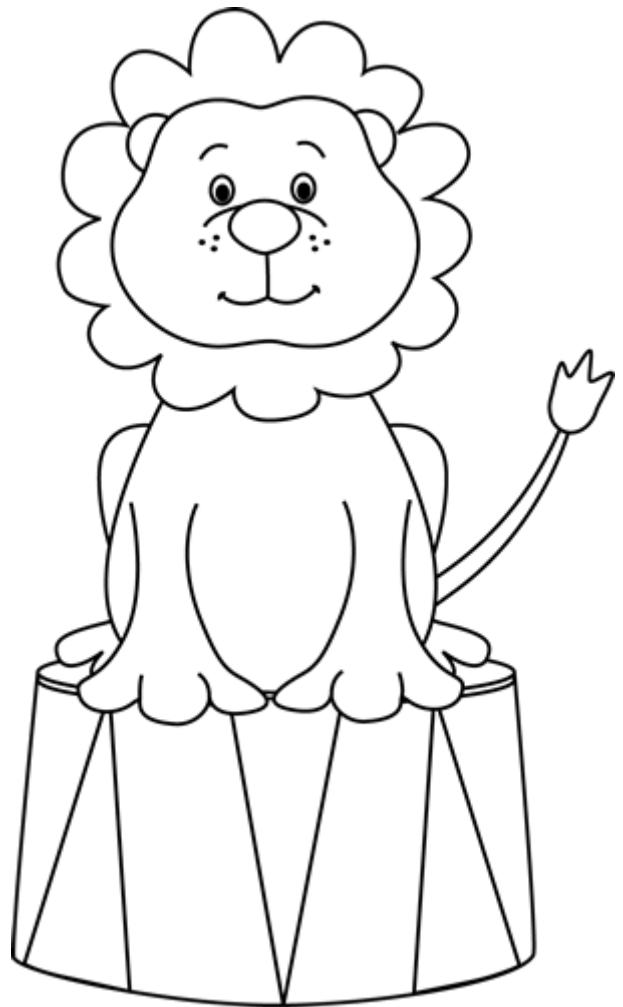
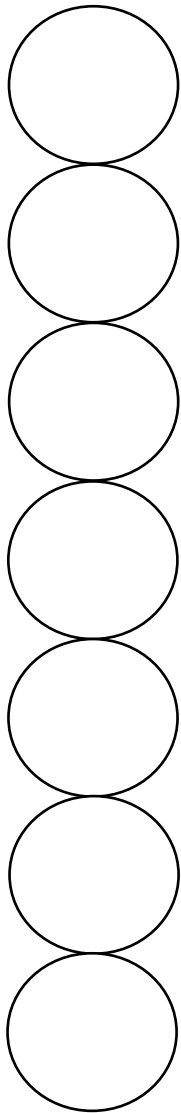

l is for lion